

**Council Minutes Index – 27 April 2023**

Subject	Page No
<b>Opening of Meeting</b> .....	<b>3</b>
<b>Acknowledgment of Country</b> .....	<b>3</b>
<b>Attendance, Apologies and Leave of Absence</b> .....	<b>3</b>
<b>Attendance of Gallery</b> .....	<b>3</b>
<b>Responses to Previous Questions Taken on Notice</b> .....	<b>3</b>
<b>Public Question Time</b> .....	<b>3</b>
<b>Petitions/Deputations/Presentations</b> .....	<b>3</b>
<b>Comments on Agenda Items by Parties with an Interest</b> .....	<b>3</b>
<b>Applications for Leave of Absence</b> .....	<b>3</b>
<b>Confirmation of Minutes</b> .....	<b>4</b>
C.01/0423 Ordinary Council Meeting held 30 March 2023 .....	4
<b>Announcements by the Presiding Member Without Discussion</b> .....	<b>4</b>
<b>Notification of Disclosure of Interest</b> .....	<b>5</b>
<b>Questions on Agenda Items by Elected Members</b> .....	<b>5</b>
<b>Consideration of Motions of which Previous Notice has been Given</b> .....	<b>5</b>
<b>Reports of Officers</b> .....	<b>5</b>
<b>CEO's Office</b> .....	<b>6</b>
C.02/0423 Elected Member Committee Membership to Fill Vacancies .....	6
C.03/0423 Change of Purpose – Reserve 40973 .....	12
C.04/0423 Rolling Action Sheet .....	14
<b>Corporate Services</b> .....	<b>15</b>
C.05/0423 Bridgetown as an RV Friendly Town and Greenbushes Pool as an RV Friendly Destination.....	15
C.06/0423 2023 Information Statement.....	19
C.07/0423 List of Accounts Paid in March 2023 .....	23
C.08/0423 Budget Management Report – March 2023 .....	26
<b>Development, Community and Infrastructure</b> .....	<b>28</b>
C.09/0423 Trial Partnership with BYA – Mainstream Youth Activities.....	28
C.10/0423 Reflect Reconciliation Action Plan .....	31
C.11/0423 Greenbushes Youth Precinct Concept Design.....	35

<b>Receival of Minutes from Management Committees .....</b>	<b>38</b>
<b>Urgent Business Approved by Decision.....</b>	<b>38</b>
<b>Responses to Elected Member Questions Taken on Notice .....</b>	<b>38</b>
<b>Elected Members Questions With Notice .....</b>	<b>38</b>
<b>Notice of Motions for Consideration at the Next Meeting .....</b>	<b>38</b>
<b>Matters Behind Closed Doors (Confidential Items) .....</b>	<b>38</b>
C.12/0423 Kerbside Waste Collection and Processing Contract.....	39
<b>Closure .....</b>	<b>40</b>
<b>List of Attachments .....</b>	<b>40</b>

## MINUTES

For an Ordinary Meeting of Council held in Council Chambers on 27 April 2023, commencing at 5.30pm.

### **Opening of Meeting**

*The Presiding Member opened the meeting at 5.30pm.*

### **Acknowledgment of Country**

*We acknowledge the cultural custodians of the land on which we gather, the Pibulmun-Wadandi people. We acknowledge and support their continuing connection to the land, waterways and community. We pay our respects to members of the Aboriginal communities and their culture; and to Elders past and present, their descendants still with us today, and those who will follow in their footsteps.*

### **Attendance, Apologies and Leave of Absence**

President	- Cr J Mountford
Councillors	- J Boyle
	- E Browne
	- M Christensen
	- T Lansdell
	- S Mahoney
	- A Pratico
	- P Quinby
	- A Rose
Officers	- T Clynch, Chief Executive Officer
	- M Larkworthy, Director Corporate Services
	- P St John, Director Development, Community, and Infrastructure
	- E Matthews, Executive Assistant

### **Attendance of Gallery**

D.Hocking, C. Rose, K. Hill

**Responses to Previous Questions Taken on Notice** - Nil

**Public Question Time** - Nil

**Petitions/Deputations/Presentations** - Nil

**Comments on Agenda Items by Parties with an Interest** - Nil

**Applications for Leave of Absence** - Nil

## **Confirmation of Minutes**

**C.01/0423 Ordinary Council Meeting held 30 March 2023**

*That the Minutes of the Ordinary Meeting of Council held 30 March 2023 be confirmed as a true and correct record.*

### **Council Decision Moved Cr Pratico, Seconded Cr Browne**

**C.01/0423 That the Minutes of the Ordinary Meeting of Council held 30 March 2023 be confirmed as a true and correct record.**

**Carried 9/0**

## **Announcements by the Presiding Member Without Discussion**

*Tonight we have the unusual experience of saying goodbye to two of our valued Councillors.*

*Councillors Quinby and Rose are both moving away from Bridgetown for personal reasons which of course means they can't see out their terms on Council.*

*Cr Quinby has given nearly 7 years of service on Council – with a hiatus of 2 years in the middle, presumably to have a breather from the mountains of reading!*

*Whilst on Council, Peter has been on the Access and Inclusion Advisory Committee, Audit Committee, Bush Fires, Sustainability and Trails Development Advisory committees and he has been Council's delegate to the BGBTA committee.*

*Peter is a quiet contributor to the workings of Council, often coming up with a particularly sage point of view at the appropriate time. Also having a great memory for what's gone before, he's been able to provide valuable background to ongoing issues. He's always worked well with Shire staff over the years with services and equipment procurements from his business The Right Stuff and Peter we can always rely on you to read out a motion at Council meetings when no-one else seems keen to jump in!*

*We thank you for your service and Steph's own service as a Councillor here too. You will both be missed by us here in this room and in the broader community.*

*Councillor Rose has only been on Council for 18 months but she has definitely made an impression.*

*Amanda has served on the Access & Inclusion, Audit, CEO Performance Review, Cultural Inclusion and Youth Services committees and as Council's representative on the BGBTA committee.*

*Amanda was the Councillor who brought forward the idea to create a new Acknowledgement of Country for the Shire via the new Cultural Inclusion Advisory Committee which was a new committee created in 2021 from a motion Amanda herself brought to Council.*

*Cr Rose was also responsible for starting Cuppa with a Councillor and has been a driving force for the changes brought through the CEO Performance Review Committee. Amanda has also put considerable energy into the re-invention of the*

*Visitor's Centre and has had keen input over her time here into streamlining and re-wording policies and documents as they have come up for review.*

*A force to be reckoned with, even when charging around on walking sticks, you have been a genuine contributor Amanda and we thank you.*

*We wish you and Chris well in your new home.*

### **Notification of Disclosure of Interest**

Section 5.65 and 5.70 of the *Local Government Act 1995* requires a Member or Officer who has an interest in any matter to be discussed at a committee/council meeting that will be attended by the Member or Officer must disclose the nature of the interest in a written notice given to the Chief Executive Officer before the meeting; or at the meeting before the matter is discussed.

A Member who makes a disclosure under section 5.65 or 5.70 must not preside at the part of the meeting relating to the matter; or participate in; or be present during any discussion or decision making procedure relating to the matter, unless allowed by the committee/council. If committee/council allows a Member to speak, the extent of the interest must also be stated.

Nil

### **Questions on Agenda Items by Elected Members**

Cr Christensen asked a question regarding item C.07/0423.

Cr Mahoney asked a question regarding item C.02/0423.

### **Consideration of Motions of which Previous Notice has been Given - Nil**

### **Reports of Officers**

Reports of Officers have been divided into Departments as follows:

- CEO's Office
- Corporate Services
- Development, Community and Infrastructure

## CEO's Office

<b>ITEM NO.</b>	C.02/0423	<b>FILE REF.</b>	220
<b>SUBJECT</b>	Elected Member Committee Membership to Fill Vacancies		
<b>PROPONENT</b>	Council		
<b>OFFICER</b>	Executive Assistant		
<b>DATE OF REPORT</b>	14 April 2023		

Attachment 1	Policy M.42 – Advisory Committees
Attachment 2	Access and Inclusion Advisory Committee Instrument of Appointment
Attachment 3	Audit Committee Instrument of Appointment
Attachment 4	CEO Performance Review Committee Instrument of Appointment
Attachment 5	Cultural Inclusion Advisory Committee Instrument of Appointment
Attachment 6	Youth Services Advisory Committee Instrument of Appointment

### OFFICER RECOMMENDATION

*That Council, noting the resignations of Cr Rose and Cr Quinby:*

- 1. Appoint \_\_\_\_\_ to fill the vacancy on the Access and Inclusion Advisory Committee*
- 2. Appoint \_\_\_\_\_ to fill the vacancy on the Audit Committee and update the Instrument of Appointment to reduce the elected member representation to three [3]*
- 3. Appoint \_\_\_\_\_ to fill the vacancy on the CEO Performance Review Committee and update the Instrument of Appointment to reduce the elected member representation to three [3]*
- 4. Appoint \_\_\_\_\_ to fill the vacancy on the Cultural Inclusion Advisory Committee*
- 5. Amend the Instrument of Appointment of the Youth Services Advisory Committee to reduce the elected member representation to one [1], thereby noting that no additional appointments are required*
- 6. Appoint \_\_\_\_\_ as Council's representative to the Bridgetown Greenbushes Business & Tourism Association.*

### Summary/Purpose

Cr Rose & Quinby's retirement has led to elected member vacancies on the following advisory committees;

- Access and Inclusion Advisory Committee
- Audit Committee
- CEO Performance Review Committee
- Cultural Inclusion Advisory Committee

- Youth Services Advisory Committee

A new Council delegate is also required for the Bridgetown Greenbushes Business & Tourism Association.

#### Background and Officer Comment

Council adopted Policy M.42 – Advisory Committees in November 2022 providing direction on committee membership. Comments are set out below on each vacancy.

#### Access and Inclusion Advisory Committee

The objectives of the Access and Inclusion Advisory Committee are to advise Council on the establishment of priorities and review of progress on the implementation of the strategies identified in the relevant Disability Access and Inclusion Plan and the Age Friendly Communities Plan.

The resignations of Cr Rose & Quinby have resulted in there being no elected member representation on the committee.

The Instrument of Appointment (IoA) prescribes a minimum of 1 elected member as Council's representative.

Clause 4.3.5 of Policy M.42 – Advisory Committees requires any committee exceeding the membership limits as set out in clause 4.3.2 (membership capped at ten) transition to the recommended membership following the vacation of a member(s). As there are 9 community representatives on the committee, it is recommended that only one elected member be appointed to the committee in order to remain in accordance with the policy.

#### Audit Committee

The primary objective of the Audit Committee is to accept responsibility for the annual external audit and meet with the local government's auditor (at least once in every year) so that Council can be satisfied with the performance of the local government in managing its financial affairs.

With the resignations of Cr Rose and Cr Quinby, the remaining committee members are Cr Mountford and Cr Mahoney. In accordance with Policy M.42 – Advisory Committees clauses 4.3.2 (a maximum of three councillors) and 4.3.5 (transition process), it is recommended that Council resolve to fill only one of the vacancies created by Cr Rose & Quinby's departure and update the IoA accordingly.

#### CEO Performance Review Committee

The CEO Performance Review Committee assists Council in the annual review process of the CEO and the setting (and review) of Key Performance Indicators (KPI's) for the ensuing 12 month period that reflect the CEO's personal performance and also that for the organisation as a whole.

With the resignation of Cr Rose the remaining committee members are Cr Mahoney and Cr Mountford. It is recommended that Council appoint an elected member to the committee and update the IoA to reduce the membership to 3 elected members, in accordance with clause 4.3 of Policy M.42 – Advisory Committees.

### Cultural Inclusion Advisory Committee

The objectives of the Cultural Awareness Advisory Committee are to advise Council on ways to;

- Grow recognition and respect for all cultures.
- Develop and implement reconciliation actions and strategies.
- Facilitate the collection and sharing of information and stories about local culture and history including NAIDOC week events and Harmony Week activities and events.
- Develop cultural inclusion events and events calendar.
- Identify, preserve and showcase significant local history and heritage including promotion of indigenous history.

The Cultural Inclusion Advisory Committee is made up of community representatives from a variety of cultural backgrounds and it is recommended that Council replace the vacancy created by Cr Rose. The current Councillor representatives on the committee are Crs Browne and Lansdell, with the Instrument of Appointment stipulating a membership of 3 elected members. As there are 7 community representative positions on the committee, the inclusion of a third elected member representative will remain within the parameters of the membership cap.

### Youth Services Advisory Committee

The objectives of the Youth Services Advisory Committee are to provide advice and input into a review of Council's Youth Plan and to provide advice and input into the prioritisation of strategies and actions contained within the Plan.

Cr Lansdell is the remaining elected member representative on the Committee, with the IoA requiring 2 Council representatives. As there are currently 9 community representatives on the committee it is recommended that Council update the Instrument of Appointment to reduce the elected member representation to 1, in accordance with Policy M.42 – Advisory Committees clause 4.3.5.

### Bridgetown Greenbushes Business & Tourism Association (BGBTA)

The BGBTA sees benefit in having an elected member representative on their committee as two of their goals are promotion of the Shire as a destination and growing of the local economy. It is recommended that Council appoint a replacement for Cr Rose as its delegate.

### Nomination Process to fill Vacancies

This item will be pulled by the CEO at the meeting and nominations for the vacancies will be sought. If more nominations than vacancies are received a secret ballot will be held.

### Statutory Environment

#### *Local Government Act 1995*

#### **5.10. Committee members, appointment of**

- (1) A committee is to have as its members —
- (a) persons appointed\* by the local government to be members of the committee (other than those referred to in paragraph (b)); and
  - (b) persons who are appointed to be members of the committee under subsection (4) or (5).

\* Absolute majority required.

- (2) At any given time each council member is entitled to be a member of at least one committee referred to in section 5.9(2)(a) or (b) and if a council member nominates himself or herself to be a member of such a



committee or committees, the local government is to include that council member in the persons appointed under subsection (1)(a) to at least one of those committees as the local government decides.

- (3) Section 52 of the Interpretation Act 1984 applies to appointments of committee members other than those appointed under subsection (4) or (5) but any power exercised under section 52(1) of that Act can only be exercised on the decision of an absolute majority of the council.
- (4) If at a meeting of the council a local government is to make an appointment to a committee that has or could have a council member as a member and the mayor or president informs the local government of his or her wish to be a member of the committee, the local government is to appoint the mayor or president to be a member of the committee.

#### **7.1A Audit Committee**

- (2) The members of the audit committee of a local government are to be appointed\* by the local government and at least 3 of the members, and the majority of the members, are to be council members.

\* Absolute majority required

#### Integrated Planning

- Strategic Community Plan
- Outcome 13 proactive, visionary leaders who respond to community needs
- Objective 13.1 strengthen leadership and advocacy
  
- Corporate Business Plan - Nil
- Long Term Financial Plan – Nil
- Asset Management Plans – Not applicable
- Workforce Plan – Not applicable
- Other Integrated Planning - Nil

#### Policy/Strategic Implications

#### **M.42 – Advisory Committees**

##### 4.3 Membership

- 4.3.1 All Advisory Committees that have community members must have a minimum of five members, comprising of:
  - A minimum of one Councillor; and
  - A minimum of four community members.
  
- 4.3.2 Other than the Bush Fires Advisory Committee and Local Emergency Management Committee, Advisory Committee memberships will be capped at ten, including:
  - a minimum of one councillor, and a maximum of three councillors
  - a minimum of four and a maximum of nine independent members, noting that where a committee has two Councillor Representatives, up to eight independent members can be appointed, but where a committee has three Councillor Representatives, up to seven independent members can be appointed.
  
- 4.3.5. Any Committees currently in existence that exceed this membership limit may continue to operate, but as members vacate the positions, they will not be replaced to allow the Committee to transition to the recommended membership.

Budget Implications - Nil

Whole of Life Accounting - Nil

Risk Management – Nil

Voting Requirements – Absolute Majority

**Moved** Cr Rose, Seconded Cr Christensen

That Council, noting the resignations of Cr Rose and Cr Quinby:

1. Appoint \_\_\_\_\_ to fill the vacancy on the Access and Inclusion Advisory Committee
2. Appoint \_\_\_\_\_ to fill the vacancy on the Audit Committee and update the Instrument of Appointment to reduce the elected member representation to three [3]
3. Appoint \_\_\_\_\_ to fill the vacancy on the CEO Performance Review Committee and update the Instrument of Appointment to reduce the elected member representation to three [3]
4. Appoint \_\_\_\_\_ to fill the vacancy on the Cultural Inclusion Advisory Committee
5. Amend the Instrument of Appointment of the Youth Services Advisory Committee to reduce the elected member representation to one [1], thereby noting that no additional appointments are required
6. Appoint \_\_\_\_\_ as Council's representative to the Bridgetown Greenbushes Business & Tourism Association
7. Amend the Instrument of Appointment for the CEO Performance Review Committee to change the objective of the Committee to "The objective of the performance appraisal is not only to measure and improve performance against specific and agreed goals / targets, but also to increase future potential and value to Council and Shire, as well as using the system to recognise and potentially reward achievement".

**Amendment** Moved Cr Lansdell, Seconded Cr Quinby

Change Part 5 to read:

5. Appoint \_\_\_\_\_ to fill the vacancy on the Youth Services Advisory Committee and amend the Instrument of appointment to remove 1 representative from Police, 1 representative from the Greenbushes Community Resource Centre, 1 representative from the justice sector and 1 representative from the community, to reduce the service agency and community group representatives to a total of 8 plus two councillors.

**Carried 9/0**

**Council Decision Moved Cr Mahoney, Seconded Cr Rose**  
**C.02/0423 That Council invoke clause 18.1 of the Standing Orders at 5.45pm**  
**to allow for informal discussion.**

**Carried 9/0**

Interest was sought from councillors to fill the vacancies on the committees and BGBTA. As more than one councillor sought appointment to the BGBTA, a secret ballot was held to determine the elected member representative (Cr Christensen or Cr Pratico) to the BGBTA, with Cr Christensen being elected.

**Council Decision Moved Cr Mahoney, Seconded Cr Rose**  
**C.02/0423a That application of clause 18.1 of the Standing Orders cease at**  
**5.49pm.**

**Carried 9/0**

**Amendment** Moved Cr Christensen, Seconded Cr Browne

Include the names of the elected member representatives in parts 1 to 6:

1. Appoint Cr Mountford to fill the vacancy on the Access and Inclusion Advisory Committee
2. Appoint Cr Browne to fill the vacancy on the Audit Committee and update the Instrument of Appointment to reduce the elected member representation to three [3]
3. Appoint Cr Christensen to fill the vacancy on the CEO Performance Review Committee and update the Instrument of Appointment to reduce the elected member representation to three [3]
4. Appoint Cr Boyle to fill the vacancy on the Cultural Inclusion Advisory Committee
5. Appoint Cr Browne to fill the vacancy on the Youth Services Advisory Committee and amend the Instrument of appointment to remove 1 representative from Police, 1 representative from the Greenbushes Community Resource Centre, 1 representative from the justice sector and 1 representative from the community, to reduce the service agency and community group representatives to a total of 8 plus two councillors.
6. Appoint Cr Christensen as Council's representative to the Bridgetown Greenbushes Business & Tourism Association

**Carried 9/0**

The amendments were incorporated into the substantive motion and was put.

**Council Decision Moved Cr Rose, Seconded Cr Christensen**

**C.02/0423b That Council, noting the resignations of Cr Rose and Cr Quinby:**

- 1. Appoint Cr Mountford to fill the vacancy on the Access and Inclusion Advisory Committee**
- 2. Appoint Cr Browne to fill the vacancy on the Audit Committee and update the Instrument of Appointment to reduce the elected member representation to three [3]**
- 3. Appoint Cr Christensen to fill the vacancy on the CEO Performance Review Committee and update the Instrument of Appointment to reduce the elected member representation to three [3]**
- 4. Appoint Cr Boyle to fill the vacancy on the Cultural Inclusion Advisory Committee**
- 5. Appoint Cr Browne to fill the vacancy on the Youth Services Advisory Committee and amend the Instrument of appointment to remove 1 representative from Police, 1 representative from the Greenbushes Community Resource Centre, 1 representative from the justice sector and 1 representative from the community, to reduce the service agency and community group representatives to a total of 8 plus two councillors.**
- 6. Appoint Cr Christensen as Council's representative to the Bridgetown Greenbushes Business & Tourism Association**
- 7. Amend the Instrument of Appointment for the CEO Performance Review Committee to change the objective of the Committee to "The objective of the performance appraisal is not only to measure and improve performance against specific and agreed goals / targets, but also to increase future potential and value to Council and Shire, as well as using the system to recognise and potentially reward achievement".**

**Carried by Absolute Majority 9/0**

Reason for amending the officer recommendation: to update the instrument of appointment for the CEO Performance Review Committee to better align with its intent, and to remove vacant positions on the Youth Services Advisory Committee to allow for a second councillor representative.
--

<b>ITEM NO.</b>	C.03/0423	<b>FILE REF.</b>	RES40973
<b>SUBJECT</b>	Change of Purpose – Reserve 40973		
<b>PROPONENT</b>	Department of Fire and Emergency Services		
<b>OFFICER</b>	Executive Assistant		
<b>DATE OF REPORT</b>	17 April 2023		

**OFFICER RECOMMENDATION**

*That Council authorise the CEO to submit an application to the to the Department of Planning, Lands and Heritage to change the purpose of Reserve 40973 to include telecommunications.*

### Summary/Purpose

To correct an anomaly in the current vesting and management order for Reserve 40973.

### Background

Located to the rear of the Shire Works Depot is Reserve 40973, set aside for the purpose of "gravel". All gravel extraction works at this reserve were completed many years ago and the reserve is now predominantly used for storage and disposal of inert material and green waste.

Also located on Reserve 40973 is a communications tower owned and operated by the Department of Fire & Emergency Services (DFES). A review of legal documentation associated with the communications tower determined that this use isn't consistent with the purpose of the reserve (gravel) nor is there any authority to the Shire under the reserve's management order to sub-lease or licence any portion of the reserve.

Council, in May 2021 resolved (C.02/0521) to endorse a proposal to amalgamate Reserves 25978 and 40973 into a single reserve for the purpose of 'Recreation and Municipal Purposes'. Since that time further legal advice has been obtained by DFES advising that the specific purpose of the reserve should include 'telecommunications'. Accordingly, the proposed amalgamation of Reserves 40973 and 25978 hasn't proceeded. It is now recommended that the reserves remain independent of each other and that an application be submitted to the Department of Planning Lands and Heritage (DPLH) to change the purpose of Reserve 40973 to include telecommunications.

DFES is seeking an amendment to the management orders pertaining to both reserves to grant the Shire the right to lease or licence the tower on Reserve 40973 and provide the lessee/licensee with access to the tower through Reserve 25336. Council has granted the CEO delegated authority to permit the granting of power to the Shire to lease or licence the land.

### Officer Comment

Consultation on this proposal hasn't been carried out as the proposal is considered minor and won't impact or change the current usage of either reserve.

### Statutory Environment

#### *Land Administration Act 1997*

#### **46. Care, control and management of reserves**

- (1) The Minister may by order place with any one person or jointly with any 2 or more persons the care, control and management of a reserve for the same purpose as that for which the relevant Crown land is reserved under section 41 and for purposes ancillary or beneficial to that purpose and may in that order subject that care, control and management to such conditions as the Minister specifies.
- (2) The Minister may, with the consent of the management body of a reserve and of the holders of any interests within the reserve, by order vary any condition to which the care, control and management of the reserve is subject.
- (3) The Minister may —
  - (a) by order confer on a management body power, subject to section 18, to grant a lease or sublease or licence over the whole or any part of the Crown land within the reserve in question for the purposes referred to in subsection (1)

Integrated Planning

- Strategic Community Plan  
Objective 14 effective governance and financial management
- Corporate Business Plan - Nil
- Long Term Financial Plan - Nil
- Asset Management Plans - Nil
- Workforce Plan - Nil
- Other Integrated Planning - Nil

Policy/Strategic Implications - Nil

Budget Implications – Nil

Whole of Life Accounting – Not applicable

Risk Management – Nil

Voting Requirements – Simple Majority

**Council Decision Moved Cr Quinby, Seconded Cr Browne  
C.03/0423 That Council authorise the CEO to submit an application to the  
Department of Planning, Lands and Heritage to change the purpose of Reserve  
40973 to include telecommunications.**

**Carried 9/0**

<b>ITEM NO.</b>	C.04/0423	<b>FILE REF.</b>	209
<b>SUBJECT</b>	Rolling Action Sheet		
<b>OFFICER</b>	Executive Assistant		
<b>DATE OF REPORT</b>	19 April 2023		

Attachment 7 Rolling Action Sheet – April 2023

**OFFICER RECOMMENDATION**

*That the information contained in the Rolling Action Sheet be noted.*

Summary/Purpose

The presentation of the Rolling Action Sheet allows Councillors to be aware of the current status of previous resolutions/decisions that have not been finalised.

Background

The Rolling Action Sheet has been reviewed and forms an Attachment to this Agenda.

Statutory Environment – Nil

Integrated Planning

- Strategic Community Plan - Nil
- Corporate Business Plan - Nil
- Long Term Financial Plan – Not applicable
- Asset Management Plans – Not applicable
- Workforce Plan – Not applicable
- Other Integrated Planning - Nil

Policy Implications – Not Applicable

Budget Implications – Not Applicable

Whole of Life Accounting – Not Applicable

Risk Management – Not Applicable

Voting Requirements – Simple Majority

**Council Decision Moved Cr Boyle, Seconded Cr Browne  
C.04/0423 That the information contained in the Rolling Action Sheet be noted.**

**Carried 9/0**

### **Corporate Services**

<b>ITEM NO.</b>	C.05/0423	<b>FILE REF.</b>	
<b>SUBJECT</b>	Bridgetown as an RV Friendly Town and Greenbushes Pool as an RV Friendly Destination		
<b>PROPONENT</b>	Council		
<b>OFFICER</b>	Manager Visitor Servicing		
<b>DATE OF REPORT</b>	18 <sup>th</sup> April 2023		

### **OFFICER RECOMMENDATION**

*That Council authorise the CEO to sign:*

1. *The Letter of Understanding acknowledging that the town of Bridgetown has met the criteria to be accepted as an 'RV Friendly Town'*
2. *The Letter of Understanding acknowledging that the Greenbushes Pool has met the criteria to be accepted as an 'RV Friendly Destination'.*

### **Summary/Purpose**

The recommendations seek to progress Councils recognised RV Friendly Town and RV Friendly Destination Status to promote the Shire's RV facilities to a wider and targeted audience.

### **Background**

The classifications of RV Friendly Town and RV Friendly Community are awarded by the Campervan & Motorhome Club of Australia. (CMCA).

Procurement of RV friendly town status has been a recurring request from the wider community over several years and during previous iterations of consultation in development of Strategic Community Plans. The October 2020 Community Scorecard results (which informed the development of the current Strategic Community Plan) identified a community view that there is a need to attract tourists as a high priority action.

An assessment of the logical sites in Bridgetown (railway car park) and Greenbushes (Sportsground and Greenbushes Pool free camping areas) has been conducted. Without a dump point Greenbushes would only meet the 'RV Friendly Destination' classification noting however it does meet all other criteria for this classification. Free camping at both sites in Greenbushes has been occurring for a number of years and broad community acceptance exists.

In July 2022 (C.05/0722) Council endorsed the continuation of 24 hour free camping for self-contained motorhomes and caravans in the railway car park, Bridgetown, where other essential RV Friendly Town criteria such as a dump point and access to potable water is located

As part of the Corporate Business Plan there is an action to facilitate key stakeholders in achieving RV Friendly Town Status. In December 2023 the WA representative of CMCA visited Bridgetown and Greenbushes to inspect the nominated sites of railway carpark in Bridgetown, and both Greenbushes Pool and Greenbushes Sportsground. The assessment led to the Greenbushes Pool being identified as meeting the criteria as an RV Friendly Destination.

#### Officer Comment

The RV Friendly Town and RV Friendly Destination classifications are initiatives of the Campervan and Motorhome Club of Australia (CMCA). To achieve either of these classifications a town must provide a specific level of amenity and service to travellers. These are:

#### RV Friendly Town Essential Criteria:

- Provision of appropriate parking within the town centre, with access to a general shopping area for groceries and fresh produce
- Provision of short-term, low-cost overnight parking (24/48 hours) for self-contained recreational vehicles as close as possible to the CBD
- Access to potable water
- Access to a free dump point at an appropriate location.

In January 2023, the CMCA acknowledged that the town of Bridgetown has met the criteria to be accepted as an 'RV Friendly Town'. A Letter of Understanding was subsequently provided, acknowledging a mutual understanding for the township of Bridgetown to be part of the Program.

By signing this Letter of Understanding, Council agree to the following conditions:

- Council has agreed to allow parking adjacent to the shopping precinct suitable for motorhomes, campervans and caravans.



- Council have agreed to allow short term overnight parking (24 hours) for self-contained motorhomes, campervans and caravans at the railway car park..
- No camping/permit fees will apply.
- Council agrees that there is a free public dump point located at the railway car park..
- Council agrees that there is potable water available at the railway car park.

CMCA will supply the Shire with two RV Friendly town signs free of charge.

CMCA has given an undertaking to promote the township and associated tourist attractions in its magazine *The Wanderer*. CMCA will also promote the town and approved events on the CMA website.

Also in January 2023, the CMCA acknowledged that Greenbushes Pool has met the criteria to be accepted as an 'RV Friendly Destination'. A Letter of Understanding was subsequently provided, acknowledging a mutual understanding for the Greenbushes Pool to be part of the Program.

Greenbushes Pool met the assessment criteria of;

- Low cost or no cost parking for 72 hours.
- Rubbish bins, BBQ, toilets, play area and water available.
- Attraction of Greenbushes Pool.

By signing this Letter of Understanding, Council agree to the following conditions:

- Shire of Bridgetown-Greenbushes has agreed to allow short term overnight parking (72 hours) for self-contained motorhomes, campervans and caravans at Greenbushes Pool..
- No camping/permit fees will apply.
- Shire of Bridgetown-Greenbushes and CMCA authorise the implementation of web links between their respective web sites for the purposes of promoting Greenbushes Pool as an RV Friendly Destination.

CMCA will supply the shire with one RV Friendly Destination sign at a cost of \$75.

CMCA has given an undertaking to promote the township and associated tourist attractions in its magazine *The Wanderer*. CMCA will also promote the town and approved events on the CMA website.

There are many benefits to becoming an 'RV Friendly Town' and 'RV Friendly Destination' with more exposure through networks of CMCA and other caravan and camping publications, e.g. Caravan Industry Association Western Australia. Providing a better service to these visitors will also reflect positively for Bridgetown-Greenbushes, providing more options and information available for people to plan their stay and vacations. It is also a trusted brand for visitors to recognise when they come to stay.

There may be a need to review cleaning schedules and bin services to the camping locations as a result of the extra promotion as a result of these classifications. Note achieving these classifications doesn't mean unlimited camping of self-contained motorhomes, campervans and caravans applies. Council has already set limits on the number that can be parked at the railway car park and signage is erected at the Greenbushes Pool limiting the number of sites.

Statutory Environment - Nil

Integrated Planning

- Strategic Community Plan
  - Outcome 12                      Bridgetown Greenbushes is regarded to be a major tourist destination
  - Objective 12.2                Improve tourism infrastructure and services.
  
- Corporate Business Plan
  - Objective 12.2                Improve tourism infrastructure and services.
  - Action 12.2.4                Facilitate key stakeholder engagement in achieving RV friendly town status
  
- Long Term Financial Plan - Nil
- Asset Management Plans – Not applicable
- Workforce Plan – Not applicable
- Other Integrated Planning - Nil

Policy Implications - Nil

Budget Implications

Budget implications for signage and other minor expenses to be incurred in recognising both locations as RV Friendly has been allocated in non-recurrent projects PJ21 – RV Friendly Towns.

Whole of Life Accounting - Nil

Risk Management - Nil

Voting Requirements – Simple Majority

**Council Decision Moved Cr Christensen, Seconded Cr Rose**

**C.05/0423 That Council authorise the CEO to sign:**

- 1. The Letter of Understanding acknowledging that the town of Bridgetown has met the criteria to be accepted as an 'RV Friendly Town'**
  
- 2. The Letter of Understanding acknowledging that the Greenbushes Pool has met the criteria to be accepted as an 'RV Friendly Destination'.**

**Carried 8/1**

Cr Boyle voted against the motion

<b>ITEM NO.</b>	C.06/0423	<b>FILE REF.</b>	192
<b>SUBJECT</b>	2023 Information Statement		
<b>PROPONENT</b>	Council		
<b>OFFICER</b>	Manager Governance & Risk		
<b>DATE OF REPORT</b>	12 April 2023		

Attachment 8 Shire of Bridgetown-Greenbushes 2023 Information Statement

OFFICER RECOMMENDATION

*That Council adopt the Shire of Bridgetown-Greenbushes 2023 Information Statement as presented in Attachment 8.*

Summary/Purpose

To comply with requirements of the *Freedom of Information Act 1992* (FOI Act) Council is required to adopt an Information Statement every 12 months.

An internal review of the Shire's current Information Statement has been conducted and a revised document is presented to Council for endorsement.

Background

Council is required under Part 5 of the FOI Act to annually prepare and publish an up-to-date Information Statement. The last review of Council's Information Statement was undertaken in 2022 [adopted by Council 28 April 2022 (C.15/0422)].

Officer Comment

The content of information statements conveys information to the public about the agency's (Shire) operations, the kinds of documents it holds, and the procedures for accessing them. The Shire has the discretion of publishing its Information Statement either as a standalone document or incorporated in its annual report. Section 94 of the FOI Act outlines the content required in the Information Statement.

A review of Council's current Information Statement has been undertaken to ensure all necessary information has been included as per section 94 and that information is up-to-date. The 2023 Information Statement presented for Council's endorsement (Attachment 8) incorporates the following changes:

**Contents page**

The heading has been amended to 2023 Information Statement.

Reason for Amendment

To reflect the document was last reviewed in 2023.

**Throughout the Statement**

The words "LG Act" have been replaced with "Act".

Reason for Amendment

As the full name of the legislation has been cited it is customary to refer to this as either "The Act" or just "Act".

**Page 3 - Introduction**

In the second sentence of paragraph two 'April 2022' has been amended to 'April

2023'.

Reason for Amendment

To reflect when the document was last reviewed and is current as at April 2023.

**Pages 4 and 5 – Council Structure and Committees of Council**

In the first sentence of the second paragraph under Council Structure, the words “Local Government” have been replaced with “Local government”.

In the second sentence of the first paragraph under Committee of Council, the words “Term of Office for Committees” and “Local Government Elections” have been replaced with the words “term of office of committees” and “local government elections” respectively.

Reason for Amendment

Grammatical correction.

**Page 6 – Management Structure**

The management structure has been amended.

Reason for Amendment

To reflect the current structure of the organisation.

**Pages 6 and 7 – Directorate Areas of Responsibility**

This is new section.

Reason for Amendment

To provide greater detail of the functions of each directorate, which better aligns to the requirements of s.94(a) of the FOI Act.

**Page 8 – Council Meetings**

In the second sentence of the first paragraph, the words “Agenda Items” have been replaced with “agenda items”.

Reason for Amendment

Grammatical correction.

**Page 11 – Freedom of Information Applications**

In the third sentence the words:

“Applications should be addressed to

Freedom of Information Officer

PO Box 271

Bridgetown, WA 6255

Or emailed to [btshire@bridgetown.wa.gov.au](mailto:btshire@bridgetown.wa.gov.au).”

Have been replaced with:

“Applications and enquiries should be addressed to:

Freedom of Information Officer

Shire of Bridgetown-Greenbushes

PO Box 271

Bridgetown, WA 6255

Or

Emailed to [btnshire@bridgetown.wa.gov.au](mailto:btnshire@bridgetown.wa.gov.au).”

The following wording has been added to the end of the last paragraph:  
*“of the Shire’s receipt of the properly completed Freedom of Information Request form or written application, together with the application fee”*

#### Reason for Amendment

Minor clarification made to add the Shire of Bridgetown-Greenbushes to the address as would be normal practice and to ensure applicants are aware that the 45 days for a decision commences upon the Shire receiving all the required information.

#### **Page 12 – Freedom of Information Charges**

In the second paragraph the words “31 March 2022” have been replaced with “31 March 2023”

The words “Per photocopy” and the charge of “\$0.20c” have been replaced with “Photocopying” and “\$0.20/page” respectively.

#### Reason for Amendment

To reflect the current charges as at 2023 and to make it clearer as to the costs of photocopies.

#### **Page 12 – Freedom of Information Charges**

A new section titled “Amendment of Council Records” has been added.

#### Reason for Amendment

To provide additional information to applicants regarding amending their personal information.

#### **Page 12 – Access Arrangements**

The following sentence has been added:

*“It should be noted that some documents are for viewing only as the supply of copies by the Shire may result in a breach of the Copyright Act 1968.”*

#### Reason for Amendment

To clarify that certain documents may only be viewed and that copies may not be able to be provided due to copyright.

#### **Page 13 – Refusal of Access**

This section has been replaced in its entirety.

#### Reason for Amendment

To provide more detailed information of when the shire can refuse access to documents.

#### **Page 13 and 14 – Internal and External Review**

Both sections are new.

#### Reason for Amendment

To provide detailed information on review rights of applicants.

## **Page 14 – Further Information**

The words “or in writing to:” have been added after the words “8.30am to 5.00pm”.

Contact details of the Shire have been included.

Contact details of the Office of the Information Commissioner have been removed and replaced with “refer above for contact details”.

### Reason for Amendment

Clarifying contact details.

## **Pages 16 and 17 – Appendix 1 – list of legislation administered by the Shire**

Various legislation has been updated.

### Reason for Amendment

To reflect current legislation (as at April 2023).

### Statutory Environment

Part 5 of the FOI Act requires Council to produce an Information Statement. Section 94 details the information that must be contained within the Information Statement and section 96 requires that an up-to-date statement is published at intervals of not more than 12 months.

### **94. Term used: information statement**

- (a) a statement of the structure and functions of the agency;
- (b) a description of the ways in which the functions (including, in particular, the decision-making functions) of the agency affect members of the public;
- (c) a description of any arrangements that exist to enable members of the public to participate in the formulation of the agency’s policy and the performance of the agency’s functions;
- (d) a description of the kinds of documents that are usually held by the agency including —
  - (i) which kinds of documents can be inspected at the agency under a written law other than this Act (whether or not inspection is subject to a fee or charge); and
  - (ii) which kinds of documents can be purchased; and
  - (iii) which kinds of documents can be obtained free of charge;
- (e) a description of the agency’s arrangements for giving members of the public access to documents mentioned in paragraph (d)(i), (ii) or (iii) including details of library facilities of the agency that are available for use by members of the public;
- (f) a description of the agency’s procedures for giving members of the public access to the documents of the agency under Part 2 including —
  - (i) the designation of the officer or officers to whom initial inquiries as to access to documents can be made; and
  - (ii) the address or addresses at which access applications can be lodged;
- (g) a description of the agency’s procedures for amending personal information in the documents of the agency under Part 3 including —
  - (i) the designation of the officer or officers to whom initial inquiries as to amendment of personal information can be made; and
  - (ii) the address or addresses at which applications for amendment of personal information can be lodged.

### Integrated Planning

- Strategic Community Plan
  - Outcome 14 Effective governance and financial management

Objective 14.1 Achieve excellence in organisational performance and service delivery

- Corporate Business Plan - Nil
- Long Term Financial Plan - Nil
- Asset Management Plans - Nil
- Workforce Plan - Nil
- Other Integrated Planning - Nil

Policy Implications - Nil

Budget Implications - Not applicable

Whole of Life Accounting – Not applicable

#### Risk Management

Reviewing the contents of Council's Information Statement ensures that information being provided to the public is relevant and up-to-date. Council is bound by requirements of the FOI Act and failure to review and update the Information Statement has been assessed as a moderate compliance risk with a low reputational risk.

Voting Requirements – Simple Majority

**Council Decision Moved Cr Browne, Seconded Cr Pratico  
C.06/0423 That Council adopt the Shire of Bridgetown-Greenbushes 2023  
Information Statement as presented in Attachment 8.**

**Carried 9/0**

<b>ITEM NO.</b>	C.07/0423	<b>FILE REF.</b>	131
<b>SUBJECT</b>	List of Accounts Paid in March 2023		
<b>OFFICER</b>	Manager Finance		
<b>DATE OF REPORT</b>	17 April 2023		

Attachment 9 List of Accounts Paid in March 2023

#### OFFICER RECOMMENDATION

*That Council receive the List of Accounts Paid in March 2023 as presented in Attachment 9.*

#### Summary/Purpose

Regulation 34 of the Local Government (Financial Management) Regulations 1996 (the Regulations) requires a local government to prepare each month a statement of financial activity reporting on the sources and applications of its funds. The regulations also require that where a local government has delegated to the Chief Executive Officer the exercise of its power to make payments from the municipal and trust funds,

a list of those accounts paid in a month are to be presented to the council at the next ordinary meeting (regulation 13).

### Background

In its monthly Financial Activity Statement a local government is to provide the following detail:

- (a) annual budget estimates, taking into account any expenditure incurred for an additional purpose under section 6.8(1)(b) or (c) of the *Local Government Act 1995*;
- (b) budget estimates to the end of the month to which the statement relates;
- (c) actual amounts of expenditure, revenue and income to the end of the month to which the statement relates;
- (d) material variances between the comparable amounts referred to in paragraphs (b) and (c); and
- (e) the net current assets at the end of the month to which the statement relates.

Each of the Financial Activity Statements is to be accompanied by documents containing:

- (a) an explanation of the composition of the net current assets of the month to which the statement relates, less committed assets and restricted assets;
- (b) an explanation of each of the material variances referred to in sub- regulation (1)(d); and
- (c) such other supporting information as is considered relevant by the local government.

The information in a statement of financial activity is to be shown according to nature and type classification.

The Financial Activity Statement and accompanying documents referred to in sub-regulation 34(2) are to be:

- (a) presented at an ordinary meeting of the council within 2 months after the end of the month to which the statement relates; and
- (b) recorded in the minutes of the meeting at which it is presented.

Where the local government has delegated to the CEO the exercise of its power to make payments from the municipal fund or the trust fund, Regulation 13 requires that a list of accounts paid by the CEO is to be prepared each month showing for each account paid:

- (a) the payee's name; and
- (b) the amount of the payment; and
- (c) the date of the payment; and
- (d) sufficient information to identify the transaction.

The list of accounts is to be:

- (a) presented to the council at the next ordinary meeting of the council after the list is prepared; and
- (b) recorded in the minutes of that meeting.

### Officer Comment

Due to the absence of key staff the monthly statement of financial activity for March 2023 has been deferred and will be presented to the May 2023 Council meeting.



### Statutory Environment

Sections 6.4 (Financial Report) and 6.8 (Expenditure from municipal fund not included in annual budget) of the Local Government Act 1995, and regulations 13 (List of Accounts) and 34 (Financial activity statement report) of the Local Government (Financial Management) Regulations 1996 apply.

Regulation 35(5) of the *Local Government (Financial Management) Regulations 1996* requires a local government to adopt a percentage or value to be used in statements of financial activity for reporting material variances. Council when adopting its 2022/23 budget resolved as follows:

*“C.06/0822n That Council for the financial year ending 30 June 2023 adopt a percentage of plus or minus 5% at nature or type level to be used for reporting material variances of actual revenue and expenditure in the monthly financial reports. The exception being that material variances of \$10,000 or less are non-reportable.”*

The attached financial activity statements provide an explanation of material variances in accordance with resolution C.06/0822n.

### Integrated Planning

- Strategic Community Plan  
Outcome 14                      Effective governance and financial management
- Corporate Business Plan - Nil
- Long Term Financial Plan - Nil
- Asset Management Plans - Nil
- Workforce Plan – Nil
- Other Integrated Planning – Nil

### Policy Implications

#### **F.6. Purchasing Policy**

To ensure purchasing is undertaken in an efficient, effective, economical and sustainable manner that provides transparency and accountability.

### Budget Implications

Expenditure incurred in March 2023 and presented in the list of accounts paid was allocated in the 2022/23 Budget.

Whole of Life Accounting – Not applicable

Risk Management – Not Applicable

Voting Requirements – Simple Majority

### **Council Decision Moved Cr Rose, Seconded Cr Mahoney**

***C.07/0423 That Council receive the List of Accounts Paid in March 2023 as presented in Attachment 9.***

**Carried 9/0**

<b>ITEM NO.</b>	C.08/0423	<b>FILE REF.</b>	
<b>SUBJECT</b>	Budget Management Report – March 2023		
<b>OFFICER</b>	Director Corporate Services		
<b>DATE OF REPORT</b>	1 April 2023		

Attachment 10      Budget Management Report – March 2023

**OFFICER RECOMMENDATION**

*That Council:*

1. Receive the March 2023 Budget Management Report as presented in Attachment 10

2. Amend the 2022/23 Budget as follows:

<b>Account or Job Number</b>	<b>Account or Job Description</b>	<b>Expenditure or Income Type</b>	<b>Current Budget</b>	<b>Budget Amendment</b>	<b>Amended Budget</b>
02YB	Refuse Recycling	Materials & Contracts	\$80,422	\$10,000	\$90,422
1255030	Sanitation General User Pay Charges	Other Fees & Charges	-\$60,000	-\$10,000	-\$70,000
22IN	Major Strategic Project – Greenbushes Youth Precinct	Materials & Contracts	\$483,105	\$35,000	\$518,105
Reserve	Strategic Projects Reserve	Reserve Funds	\$237,863	-\$35,000	\$202,863
<b>Total</b>				<b>\$0.00</b>	

**Summary/Purpose**

Presented is the March 2023 Budget Management Report (Attachment 10). The report contains detail of budget overspends authorised by the Chief Executive Officer and requested budget amendments for Council’s consideration.

**Background**

To aid in efficient and effective management of budget allocations Council adopted policy ‘F23 – Budget Management’ at its meeting held 15 December 2022.

**Officer Comment**

It is the function and duty of the CEO to cause Council decisions to be implemented and manage the day-to-day operations of the Shire. It is recognised the annual budget is an informed financial forecast and variations are to be expected as actual circumstances experienced may differ to initial estimates provided.

To assist in the day-to-day management of budget allocations policy F23 – Budget Management provides clear direction on the approved circumstances in which budget overspends may be authorised and the associated reporting requirements to Council. The policy provides for the following categories of budget overspends:

- Non Reportable
- Determined by the CEO and Subsequently Reported to Council
- Authorised by the Shire President

- Council Budget Amendments

The attached Budget Management Report provides information as required by the policy in relation to dot points 2 to 4 above. Budget amendments as per the officer recommendation will result in an increase to overall budget expenditure of \$45,000. This increase in expenditure is offset by increased revenue of \$10,000 and \$35,000 in funding from Reserve funds.

### Statutory Environment

#### *Local Government Act 1995*

Section 5.41 of the Local Government Act (the Act) outlines the functions of the CEO. Functions included in this section of the Act relevant to this item are:

- cause council decisions to be implemented
- manage the day-to-day operations of the local government

### **6.8 Expenditure from municipal funds not included in annual budget:**

- (1) The Council cannot incur expense from its municipal fund for a purpose for which no expense estimate is included in the annual budget (known as an 'additional purpose') except where the expense —
  - (a) is incurred in a financial year before the adoption of the annual budget by the local government;
  - (b) is authorised in advance by resolution by Absolute Majority; or
  - (c) is authorised in advance by the mayor or president in an emergency.
- (2) Where expense has been incurred;
  - (a) under s6.8 (1)(a) it is required to be included in the annual budget for that financial year; and
  - (b) under s6.8 (1)(c), it is to be reported to the next ordinary meeting of the council

### Integrated Planning

- Strategic Community Plan  
Outcome 14 Effective governance and financial management
- Corporate Business Plan - Nil
- Long Term Financial Plan - Nil
- Asset Management Plans - Nil
- Workforce Plan – Nil
- Other Integrated Planning – Nil

### Policy Implications

This report has been prepared in accordance with Council's policy F.23 - Budget Management Policy.

### Budget Implications

Budget amendments as recommended will reduce funds held in the Strategic Projects Reserve by \$35,000.

Whole of Life Accounting – Not applicable

Risk Management – Not Applicable

Voting Requirements – Simple Majority

**Council Decision Moved Cr Mahoney, Seconded Cr Browne**

**C.08/0423 That Council:**

**1. Receive the March 2023 Budget Management Report as presented in Attachment 10**

**2. Amend the 2022/23 Budget as follows:**

<b>Account or Job Number</b>	<b>Account or Job Description</b>	<b>Expenditure or Income Type</b>	<b>Current Budget</b>	<b>Budget Amendment</b>	<b>Amended Budget</b>
<b>02YB</b>	<b>Refuse Recycling</b>	<b>Materials &amp; Contracts</b>	<b>\$80,422</b>	<b>\$10,000</b>	<b>\$90,422</b>
<b>1255030</b>	<b>Sanitation General User Pay Charges</b>	<b>Other Fees &amp; Charges</b>	<b>-\$60,000</b>	<b>-\$10,000</b>	<b>-\$70,000</b>
<b>22IN</b>	<b>Major Strategic Project – Greenbushes Youth Precinct</b>	<b>Materials &amp; Contracts</b>	<b>\$483,105</b>	<b>\$35,000</b>	<b>\$518,105</b>
<b>Reserve</b>	<b>Strategic Projects Reserve</b>	<b>Reserve Funds</b>	<b>\$237,863</b>	<b>-\$35,000</b>	<b>\$202,863</b>
<b>Total</b>				<b>\$0.00</b>	

**Carried 9/0**

**Development, Community and Infrastructure**

<b>ITEM NO.</b>	C.09/0423	<b>FILE REF.</b>	860
<b>SUBJECT</b>	Trial Partnership with BYA – Mainstream Youth Activities		
<b>PROPONENT</b>	Youth Services Advisory Committee		
<b>OFFICER</b>	Manager Community Development		
<b>DATE OF REPORT</b>	April 2023		

**OFFICER RECOMMENDATION:**

*That Council approve the provision of \$3,300 from PJ07 (Youth Activities and Support) to Blackwood Youth Action, in staged payments, to facilitate a trial term program of youth activities focusing on mainstream young people, to be facilitated by Blackwood Youth Action at the Youth House.*

**Summary/Purpose**

The recommendation seeks to support an inclusion of extracurricular local activities for mainstream young people in the Shire through collaboration with Blackwood Youth Action.

### Background

At the May 2020 Council meeting (C.18/0520) Council resolved to;

1. Cease provision of youth services effective from 1 July 2020.
2. Write to Blackwood Youth Action and request the Manager Community Development be considered as an ex-officio member on their Committee to provide a conduit between Blackwood Youth Action and Council.
3. Not proceed with the proposed review of the Youth Plan.
4. That the Youth Leadership Team and Youth Services Advisory Committee be moved into recess.

These recommendations were supported by Council with the view that Blackwood Youth Action had gone from strength to strength and offered young people a vibrant, community driven service. Blackwood Youth Action were also developing their Youth House with support from community and income from their successful social enterprise business (Op Shop). It was proposed that Blackwood Youth Action would be able to provide activities for young people within the shire and shire programs would be a duplication of those programs.

The focus of Blackwood Youth Action activities and programs is on young people at risk. Their funding model focuses on supporting young people with mental health issues, those that may be disengaged at school and/or young members of the LGBTI+ community. Blackwood Youth Action also supports young people from lower socio-economic demographics, young people having difficulties with home life or those that may be impacted by drug use and other risk factors. Blackwood Youth Action do not offer programs for mainstream young people and are not funded to do so.

In the 2022/23 budget an annual budget allocation of \$10,000 was approved by Council to be used as seed funding for grants and to facilitate projects, programs and events in partnership with youth service providers.

### Officer Comment

Officers have been working closely with Blackwood Youth Action representatives and Council's Youth Services Advisory Committee to consult with young people and service providers to develop methods of filling gaps in services for young people, within the available resources of the Shire and Blackwood Youth Action. The Youth House is now in operation and weekly programs are facilitated by Blackwood Youth Action with the Youth House as their base.

It has become evident, through the ongoing engagement with young people and youth service providers, that there is a demand for activities and access to the Youth House by mainstream young people. These activities are not currently available through Blackwood Youth Action given their funding model and focus.

If Council support the officer recommendation, a trial program, targeting mainstream young people will be facilitated by Blackwood Youth Action. The program will include 1 x 2-hour weekly session at the Youth House and 2 x 5-hour school holiday activity.

The term trial cost will be;

\$50.00/hour x 2 hour sessions for 10 weeks of the term	\$2,000
\$400.00/bus trip x 2 bus trips during July school holidays (mileage rates)	\$ 800
<u>\$500 school activities facilitation \$50/hour x 10 hours (2 x 5 hr activities)</u>	<u>\$ 500</u>
Total	\$3,300

In addition to the above costs the Shire will provide promotion and branding services to an estimated value (in-kind) of \$200.

Blackwood Youth Action will provide the following during the weekly sessions targeting mainstream young people;

- Venue
- Youth Worker
- Materials
- Utilities
- Internet
- Insurances
- Admin support

The benefits for participating young people will include having access to a qualified youth worker, art therapist and workshops aimed at creating connections and fostering a sense community belonging. Youth workers will have the opportunity to identify young people that need support, develop a rapport and provide case management and referrals if required.

Once the trial is finished a report outlining the attendance, outcomes and recommendations moving forward will be presented to Council.

#### Statutory Environment - Nil

#### Integrated Planning

- Strategic Community Plan
  - Outcome 1 A growing community that is diverse, welcoming and inclusive
  - Objective 1.1 Improve family and youth services and facilities to attract and retain families
- Corporate Business Plan
  - Action 1.1.2 Partner with Blackwood Youth Action to improve access to support services, counselling and mentoring for young people in particular marginalized and at risk youth.
- Long Term Financial Plan – Not applicable
- Asset Management Plans – Not applicable
- Workforce Plan – Not applicable
- Other Integrated Planning - Nil

#### Policy Implications - Nil

#### Budget Implications

The \$3,300 costs will be drawn from Account PJ07 'Youth Activities and Support' which currently has an amount of \$5,021 unexpended.

Of the \$3,300 the bus hire costs of \$800 (estimated) will be journalled from Account PJ07 to Account 1314530 community bus fees and income.

Of the remaining \$2,500 this will be proportionally paid (i.e. fortnightly) after the activities have been undertaken.

Whole of Life Accounting - Nil

Risk Management

The recommendation mitigates Council exposure to financial risk by providing a cost-benefit analysis based on the trial period to determine the long-term viability and outcomes and benefits.

Voting Requirements –Simple Majority

**Council Decision Moved Cr Lansdell, Seconded Cr Rose**

***C.09/0423 That Council approve the provision of \$3,300 from PJ07 (Youth Activities and Support) to Blackwood Youth Action, in staged payments, to facilitate a trial term program of youth activities focusing on mainstream young people, to be facilitated by Blackwood Youth Action at the Youth House.***

**Carried 9/0**

<b>ITEM NO.</b>	C.10/0423	<b>FILE REF.</b>	860
<b>SUBJECT</b>	Reflect Reconciliation Action Plan		
<b>PROPONENT</b>	Cultural Awareness Advisory Committee		
<b>OFFICER</b>	Manager Community Services		
<b>DATE OF REPORT</b>	April 2023		

**OFFICER RECOMMENDATION:**

*That Council:*

1. *Approve the Reflect Reconciliation Action Plan process as follows;*
  - a. *Complete the 12 month Reflect Template*
  - b. *Submit the Reflect template to Reconciliation Australia for review*
  - c. *Make any changes required by Reconciliation Australia*
  - d. *Present to Council for adoption*
  - e. *Receive Reconciliation Australia endorsement for 12 Month Reflect Reconciliation Action Plan*
  
2. *Engage Sandra Hill to complete a welcome message in language with translation, and develop a language group map of the south west to include at the tourist information bays at either end of Bridgetown.*

Summary/Purpose

These recommendations seek to raise the awareness of cultural inclusion within the Shire and progress projects/activities recommended by Council's Cultural Inclusion Advisory Committee.

Background

The Cultural Inclusion Advisory Committee has been very active in raising awareness of indigenous culture and reconciliation since its establishment in November 2021

In March 2022 (C20/0322) Council, in part endorsed;

- *an annual budget allocation of \$10,000 to be used by the committee as seed funding for grants, projects, programs and events including Harmony Week and NAIDOC Week and*
- *a request for the CEO to investigate the process and cost associated with dual naming of the Blackwood River (Goorbilyup) and report the findings back to Council at the May Council Meeting.*

In October (C.09/1022) Council agreed to;

- *Support the dual naming of the Blackwood River to include the Aboriginal name - Goorbilyup.*
- *Progress the dual naming process by agreeing to;*
  - a) Consult with each of the Shires along the Blackwood River (West Arthur, Boyup Brook, Nannup and Augusta Margaret River).*
  - b) Consult with the Aboriginal Elders representing each of the language groups located along the Blackwood River (Wadandi, Pibulmun, Kaneang and possibly Wiilman)*
  - c) Consult with the Aboriginal Corporations representing each of the language groups along the Blackwood River if required.*
- 5. *Agree to engage an artist to work with each of the primary schools in the Shire to design and print banners to celebrate Harmony Week.*
- 6. *Approve the Shire becoming a member of the "Welcoming Cities" network under the free membership option.*

#### Officer Comment

The objective of the Cultural Awareness Advisory Committee is to advise Council on ways to;

- Grow recognition and respect for all cultures.
- Develop and implement reconciliation actions and strategies.
- Facilitate the collection and sharing of information and stories about local culture and history including NAIDOC week events and Harmony Week activities and events.
- Develop cultural inclusion events and events calendar.
- Identify, preserve and showcase significant local history and heritage including promotion of indigenous history.

The Cultural Inclusion Advisory Committee is made up of community members and stakeholder representatives from a variety of cultural backgrounds and organisations.

Council have supported the recommendations of the Committee on a number of projects that are progressing or have been completed, including NAIDOC and Harmony Week banners, a standardised Acknowledgement of Country for community use and working toward the dual naming of the Blackwood River. These projects have been community-based initiatives. A Reconciliation Action Plan represents an organisation's commitment to undertake all aspects of their business with a focus on inclusivity and reconciliation. This plan is a review of the operational aspects of the Shire through the lens of reconciliation to assess our operations to ensure they are inclusive and culturally aware.



The next step in progressing toward an inclusive and aware organisation is to work through the Reconciliation Action Plan (RAP) process with the support of Reconciliation Australia. As this is Council's first RAP, Reconciliation Australia provide a template and outline the process required for its endorsement.

The Reflect RAP is used to lay the foundations and prepare for future RAP's and reconciliation initiatives. The Reflect RAP will be a public commitment by the Shire, published on the Reconciliation Australia's website, toward reconciliation.

There are three pillars of every RAP – Relationships, Respect and Opportunities and there are 4 types of RAP – Reflect, Innovate, Stretch and Elevate.

The Reflect RAP template is designed to provide organisations with a roadmap to begin their reconciliation journey. As such the Reflect RAP template is pre-filled to provide the required actions and deliverables that each organisation is required to commit to in order to receive Reconciliation Australia endorsement. The Reflect RAP lasts for 12 months, during which time the organisation completes the outlined actions and provides feedback to Reconciliation Australia. Once these actions are completed Council will in a position to undertake the next type of RAP – Innovate.

A Welcome to Country in language and a language group map provide an important message for visitors and community, raising the awareness of our indigenous history and showing awareness of and respect for the original indigenous custodians of the land. A Welcome to Country in language is in alignment with cultural beliefs and traditions and supports the importance of improving cultural awareness. Providing a map of the different language group areas throughout the south west is an initiative that provides education, regional context and a point of interest for tourists and community.

#### Statutory Environment - Nil

#### Integrated Planning

##### ➤ Strategic Community Plan

- Outcome 1 A growing community that is diverse, welcoming and inclusive
- Objective 1.4 Grow recognition and respect for all cultures
- Outcome 2 Good health and community wellbeing
- Objective 2.3 Become a hub of excellence in art, culture and community events
- Outcome 8 Local history, heritage and character is valued and preserved
- Objective 8.1 Identify, preserve and showcase significant local history and heritage

##### ➤ Corporate Business Plan

- Objective 1.4 grow recognition and respect for all cultures
  - Action 1.4.1 provide a reconciliation action plan
  - Action 1.4.2 facilitate the collection and sharing of information and stories about local culture and history including NAIDOC Week and Harmony Week
- Objective 2.3 become a hub of excellence in art, culture and community events
  - Action 2.3.2 facilitate development of a local community events calendar
- Objective 8.1 identify, preserve and showcase significant local history and heritage

Action 8.1.4 partner with the Historical Society to improve promotion of local history and heritage

- Long Term Financial Plan – Not Applicable
- Asset Management Plans – Not applicable
- Workforce Plan – Not Applicable
- Other Integrated Planning - Nil

#### Policy Implications

#### Budget Implications

There are no budget implications associated with the development of the Reflect RAP. The existing budget allocation of \$30,000 (PJ130) to cover the costs of a consultant to develop the RAP will be required during the next financial year to complete the work required to develop an Innovation RAP. It would be beneficial to roll over the current budget allocation to be included in the 23/24 budget. This will assist the development of the next version of the RAP and ensure there is a budget allocation available to do so.

The signage/display of the Welcome and Map for the Information Bay that will be paid for from the Information Bay Improvements account (PJ45).

Whole of Life Accounting - Nil

#### Risk Management

The engagement of the local Aboriginal Elders to guide the committee in areas involving Aboriginal culture ensures the committee are providing culturally appropriate or sensitive recommendations to Council and supports Council's commitment to raise the awareness of cultural inclusion.

Voting Requirements – Simple Majority

#### **Council Decision Moved Cr Browne, Seconded Cr Boyle**

***C.10/0423 That Council:***

- 1. Approve the Reflect Reconciliation Action Plan process as follows;***
  - a. Complete the 12 month Reflect Template***
  - b. Submit the Reflect template to Reconciliation Australia for review***
  - c. Make any changes required by Reconciliation Australia***
  - d. Present to Council for adoption***
  - e. Receive Reconciliation Australia endorsement for 12 Month Reflect Reconciliation Action Plan***
- 2. Engage Sandra Hill to complete a welcome message in language with translation, and develop a language group map of the south west to include at the tourist information bays at either end of Bridgetown.***

**Carried 9/0**

<b>ITEM NO.</b>	C.11/0423	<b>FILE REF.</b>	500
<b>SUBJECT</b>	Greenbushes Youth Precinct Concept Design		
<b>PROPONENT</b>	Council		
<b>OFFICER</b>	Manager Community Services		
<b>DATE OF REPORT</b>	April 2023		

Attachment 11 Greenbushes Youth Precinct Detailed Design

### OFFICER RECOMMENDATION

*That Council:*

- 1. Adopt the Greenbushes Youth Precinct Detailed Design as presented in Attachment 11*
- 2. Acknowledge the generous contribution of \$160,000 made by Talison Lithium Pty. Ltd. towards the project.*

### Summary/Purpose

These recommendations seek to progress the Greenbushes Youth Precinct Stage 1 to construction.

### Background

Planning for redevelopment of the Greenbushes skate park and surrounds commenced in 2021 with a total of 48 people participating in the survey and design activities.

Council formally adopted the Greenbushes Youth Precinct Community Consultation Report in February 2022. The report included a basic layout of the Greenbushes Youth Precinct that corresponded with the findings of community consultations, designated area and budget constraints.

A second community engagement was held on 10 November 2022 in Greenbushes to review the draft concept plan for the Greenbushes Youth Precinct. Skate Sculpture proprietor Mat de Koning led the consultation. It became apparent that there was a need to fine-tune several elements of the original concept design to meet community need. The design was updated to reflect the changes outlined in the community consultation.

Construction costs were recalculated to include these changes, increasing the total budget beyond Council's original \$450,000 budget ceiling. As a result, Skate Sculpture were invited to present the concept design, community feedback and updated cost estimates to a Councillor workshop held on 5 December 2022.

The feedback from councillors was to seek additional project funding to increase the size, scope and overall appeal of the Greenbushes Youth Precinct. The proposed upgrade would require a total budget of \$600,000.

At the December Council meeting (C.17/1222) Council agreed to:

- 1. Adopt the Greenbushes Youth Precinct Concept Design Report 2022*
- 2. Having regard to funding timelines split the Greenbushes Youth Precinct project into two stages;*
  - c. Stage 1 - the skate park, court, shelter and landscaping*
  - d. Stage 2 - the pump track*

3. Note the CEO will submit a Lotterywest funding application to cover the costs associated with the construction of Stage 2 of the Greenbushes Youth Precinct project
4. Note the CEO will be calling tenders for the design of the whole project and construction of Stage 1 of the project.

The CEO sought submissions for this project from suitable contractors through the WALGA Preferred Vendor Platform and received 1 submission from Skate Sculpture.

Council, at a special meeting held on 9 February 2023 resolved:

*SpC.03/0223 That Council:*

1. Accept the proposal from Skate Sculpture dated 1 February 2023 for the detailed design and construction of elements of the Greenbushes Youth Precinct (stage 1) including Skate Park, Quarter Basketball Court, Shelter and Outdoor Furniture in accordance with the Greenbushes Youth Precinct Plan and Report for the contract value of \$483,104.70
2. Authorise the Chief Executive Officer to negotiate cost elements of the contract as long as the total value of the contract does not exceed \$483,105
3. Amend the 2022/23 budget by;
  - i. increasing the expenditure allocation of Job No. 22IN 'Major Strategic Project – Greenbushes Youth Precinct' by \$33,105, from \$450,000 to \$483,105
  - ii. increasing income in account 1344530.92 'Other Recreation and Sport Contributions/Reimbursements' by \$160,000 from \$191,564 to \$351,564
  - iii. decreasing income in account 1344230.65 'Other Recreation and Sport Grants' by \$125,000 from \$283,164 to \$158,164
4. Determine that, in the event that a third party contribution of less than \$160,000 is received for this project by 31 March 2023, that the funding shortfall be allocated from the Strategic Projects Reserve, and that a formal budget amendment report to ratify this will be prepared at that time should this be necessary
5. Transfer an amount up to \$35,000 from the Strategic Projects Reserve to fund contingency and project management costs for Stage 1 of the project.

Since that meeting Talison Lithium Pty Ltd has confirmed its \$160,000 contribution towards the project and the contract with Skate Sculpture has been finalised.

#### Officer Comment

The formal approval of Talison Lithium's financial contribution approval toward Stage 1 of the Greenbushes Youth Precinct has been received and needs to be accepted as unbudgeted income by Council. This funding secures the full amount required for Stage 1.

#### The Funding Model

<i>Funding Body</i>	<i>Amount</i>
LRCIP Federal Government Funding	\$300,000 (ex GST)
Talison Lithium Contribution	\$160,000 (ex GST)
Shire Bridgetown Greenbushes	\$ 23,105 (ex GST)
<hr/>	
Total	\$483,105 (ex GST)

Council's formal approval of the detailed design for the Greenbushes Youth Precinct was identified as a holding point in the contract to ensure Council agree with the final detailed design before construction on the Greenbushes Youth Precinct begins.

### Stage 1

This stage includes the detailed design of the youth precinct, and the construction of the skatepark, basketball court, shade shelter and paths.

Stage 1 does not include the detailed design of the pump track as we were given advice that this would limit Council's ability to choose a contractor later in the project as this is a specialist area with specialist materials used. The company that designs the pump track will need to be the company that installs the pump track, and this will depend on the material Council chooses to use for the construction of the track.

Stage 1 does include the landscaping design but does not include the irrigation design and will not include the construction of the landscaping. The landscape construction and irrigation plan will be completed after Stage 1 has been completed and will include the construction, installation and planting of the landscape design around the Stage 1 infrastructure only. Officers have been working with Greenbushes community members to develop a process by which the community can be involved with the planting of the area and keep to the design approved by Council. Greenbushes community have already sourced plants and raised money toward the landscaping element of this project.

### Greenbushes Youth Precinct Project Schedule - Stage 1

Jan/Feb:	RFQ released
March:	Contract Awarded
April:	Fencing and Demolition Detailed design complete
May:	Construction
July:	Stage 1 construction complete

The irrigation plan and landscaping will be considered in consultation with community once construction of Stage 1 is complete.

### Statutory Environment - Not Applicable

### Integrated Planning

- Strategic Community Plan
  - Outcome 1 A growing community that is diverse, welcoming and inclusive.
  - Objective 1.1 Improve family and youth services and facilities to attract and retain families.
  - Outcome 13 Proactive, visionary leaders who respond to community needs.
  - Objective 13.1 Strengthen leadership and advocacy.
  
- Corporate Business Plan
  - Action 1.1.5 Provide the redevelopment of the Greenbushes Youth Precinct.
  - Action 13.1.2 Provide a strategic approach to seeking Government funding and support for Growth Strategy projects.

- Long Term Financial Plan – Not applicable
- Asset Management Plans – Once completed the infrastructure included in stage 1 of the Greenbushes Youth Precinct will be included in the Shire Asset Management Plan.
  
- Workforce Plan – Not applicable

Policy Implications - Nil

Budget Implications

As stated above – the project cost for Stage 1 is \$483,105. With the \$160,000 contribution from Talison Lithium Pty Ltd confirmed, there isn't a requirement for Council to draw equivalent funds from reserve.

Whole of Life Accounting

During the design stage of this project, an assessment of the maintenance requirements of the precinct will be undertaken to identify the ongoing whole of life cycle costings associated with maintenance and the required workforce implications.

Risk Management - Nil

Voting Requirements - Simple Majority

**Council Decision Moved Cr Lansdell, Seconded Cr Pratico**

**C.11/0423 That Council:**

- 1. Adopt the Greenbushes Youth Precinct Detailed Design as presented in Attachment 11**
  
- 2. Acknowledge the generous contribution of \$160,000 made by Talison Lithium Pty. Ltd. towards the project.**

**Carried 9/0**

**Receival of Minutes from Management Committees**

Nil

**Urgent Business Approved by Decision** - Nil

**Responses to Elected Member Questions Taken on Notice** - Nil

**Elected Members Questions With Notice** - Nil

**Notice of Motions for Consideration at the Next Meeting** - Nil

**Matters Behind Closed Doors (Confidential Items)**

**Council Decision Moved Cr Pratico, seconded Cr Mahoney  
C.12/0423 That Council go behind closed doors to consider Item C.12/0423 at  
6.02pm.**

**Carried 9/0**

In accordance with s.5.23(2) of the *Local Government Act 1995*, the CEO has recommended item C.12/0423 be considered behind closed doors as the subject matter relates to the following matter prescribed by section 5.23(2):

- A contract entered into, or which may be entered into, by the local government and which relates to a matter to be discussed at the meeting.

In accordance with Clause 4.2 of the Standing Orders Local Law the contents of this item is to remain confidential and must not be disclosed by a member to any person other than a member of Council or an employee of the Council to the extent necessary for the purpose of carrying out his or her duties.

<b>ITEM NO.</b>	C.12/0423	<b>FILE REF.</b>	
<b>SUBJECT</b>	Kerbside Waste Collection and Processing Contract		
<b>PROPONENT</b>	Shire of Bridgetown Greenbushes		
<b>OFFICER</b>	Manager Infrastructure		
<b>DATE OF REPORT</b>	17 April 2023		

**Council Decision Moved Cr Pratico, Seconded Cr Rose  
C.12/0423a That Council:**

- 1. Confirm Cleanaway Pty Ltd (ACN 000 164 938) as the preferred supplier for COB/5427 – Southwest Regional Waste Management Services to provide waste management services to the Shire of Bridgetown-Greenbushes**
- 2. Delegate power and authority to the Chief Executive Officer to commence negotiations with Cleanaway Pty Ltd (ACN 000 164 938) with the view to finalising the relevant contractual documentation**
- 3. If agreement cannot be reached with Cleanaway Pty Ltd (ACN 000 164 938), authorise the Chief Executive Officer to commence negotiations with the next preferred supplier with the view to finalising the relevant contractual documentation**
- 4. Subject to the above resolutions, authorise the Chief Executive Officer to enter into a contract to obtain waste management services, at the agreed rates.**

**Carried by Absolute Majority 9/0**

**Council Decision Moved Cr Rose, Seconded Cr Browne  
C.12/0423b That Council come out from behind closed doors at 6.03pm.**

**Carried 9/0**

At 6.03pm Council opened the doors to the meeting. It is noted that no members of the public returned to the meeting.

**Closure**

*The Presiding Member closed the meeting at 6.03pm.*

**List of Attachments**

Attachment	Item No.	Details
1	C.02/0423	Policy M.42 – Advisory Committees
2	C.02/0423	Access and Inclusion Advisory Committee Instrument of Appointment
3	C.02/0423	Audit Committee Instrument of Appointment
4	C.02/0423	CEO Performance Review Committee Instrument of Appointment
5	C.02/0423	Cultural Inclusion Advisory Committee Instrument of Appointment
6	C.02/0423	Youth Services Advisory Committee Instrument of Appointment
7	C.04/0423	Rolling Action Sheet - April 2023
8	C.06/0423	Shire of Bridgetown-Greenbushes 2023 Information Statement
9	C.07/0423	List of Accounts Paid in March 2023
10	C.08/0423	Budget Management Report - March 2023
11	C.11/0423	Greenbushes Youth Precinct Detailed Design

Minutes Papers prepared and recommended by E Matthews, Executive Assistant



5 May 2023

Minutes Papers authorised by T Clynch, CEO



5 May 2023

As Presiding Member, I certify that the Minutes of the Ordinary Council Meeting held 27 April 2023 were confirmed as a true and correct record of the proceedings of that meeting at the Ordinary Meeting of Council held on Thursday 25 May 2023.

..... 25 May 2023



## M.42 – Advisory Committees

---

### 1 Objectives

The objectives of this policy:

- To support Council in ensuring sound governance and management of Advisory Committees
- To ensure consistency in the formation and operation of all of Council's Advisory Committees.
- To provide a clear pathway for community to provide advice and recommendations to Council
- To outline roles and responsibilities of Advisory Committee members and Shire officers.

### 2 Scope

This policy applies to all of Council's Advisory Committees, Councillors while remaining members of an Advisory Committee, and employees responsible for Advisory Committees. The policy is also relevant to all staff and community members who may interact from time to time with an Advisory Committee.

### 3 Definitions

- 3.1 The Act** - the Local Government Act 1995.
- 3.2 Advisory Committee** - means an Advisory Committee established under this policy. In this policy a reference to advisory committee is a reference to an advisory committee of the Shire of Bridgetown-Greenbushes.
- 3.3 Committee Member** – an individual or organisation represented by a delegated person who is appointed for the term of the Advisory Committee.
- 3.4 Member Organisation** – an organisation/community group that is appointed as a Committee Member represented by a delegated person who has authority to represent the organisation/community group in decision making. The organisation/community group must be based in the shire of Bridgetown-Greenbushes.
- 3.5 Member Organisation Representative** – a person representing a Member Organisation with delegated authority to represent the organisation in decision making.
- 3.6 Responsible Officer** – a Shire staff member that is nominated by the CEO to provide administrative and governance support to an advisory committee.
- 3.7 Advisory Committee Meeting** - a Meeting of an Advisory Committee.
- 3.8 Councillor** - a current elected Councillor of Council.
- 3.9 Instrument of Appointment and Delegation** - a document which outlines the scope, purpose, authority and protocols of a Committee.
- 3.10 Quorum** - at least 50% of the number of offices whether vacant or not; a Quorum is required to hold a formal meeting of an Advisory Committee where recommendations to Council can be made.

## 4 Policy

### 4.1 Formation of an Advisory Committee

Advisory Committees must be formed (and rescinded) by Council Resolution, and the Instrument of Appointment and Delegation, and membership must also be decided by Council.

### 4.2 Powers and Functions of an Advisory Committee

Advisory Committees do not have any executive, financial or delegated powers.

Advisory Committees do not have the power to sub-delegate or form sub-committees. The role of an Advisory Committee generally is to provide appropriate advice and recommendations on matters relevant to its Instrument of Appointment and Delegation in order to assist decision making by Council.

An Advisory Committee can offer specialised advice and assistance with research on issues of interest to Council and the Community.

### 4.3 Membership

**4.3.1** All Advisory Committees that have community members must have a minimum of five members, comprising of:

- A minimum of one Councillor; and
- A minimum of four community members.

**4.3.2** Other than the Bush Fires Advisory Committee and Local Emergency Management Committee, Advisory Committee memberships will be capped at ten, including:

- a minimum of one councillor, and a maximum of three councillors;
- a minimum of four and a maximum of nine independent members, noting that where a committee has two Councillor Representatives, up to eight independent members can be appointed, but where a committee has three Councillor Representatives, up to seven independent members can be appointed.

**4.3.3** The Bush Fires Advisory Committee (BFAC) membership is to consist of up to 2 councillors, the Chief Fire Control Officer, all Deputy Chief Fire Control Officers and the Fire Control Officer (or his/her representative) from each of the Shire's bush fire brigades. A number of government agency representatives also attend BFAC meetings but are not classified as members.

**4.3.4** The Local Emergency Management Committee (LEMC) is to consist of up to 3 councillors, and representatives from the Shire, government agencies and community organisations.

**4.3.5.** Any Committees currently in existence that exceed this membership limit may continue to operate, but as members vacate the positions, they will not be replaced to allow the Committee to transition to the recommended membership.

**4.3.6** Any community member may become a member of an Advisory Committee if appointed by Council, and any such member will have the same entitlement to participate as the Councillor Representative/s. Weight will be given to ensuring diversity of membership and skills on an Advisory Committee.

**4.3.7** All Advisory Committees other than the Bush Fires Advisory Committee must have an elected Chairperson, who must be a councillor, and will, where necessary, have the casting vote.

**4.3.8** Advisory Committee members must adhere to the same standards of conduct as elected members, as defined in the Code of Conduct (Members and Staff).

- 4.3.9 Advisory committee meetings will be included in the Councillors' Calendar. Any councillor is able to attend a meeting of any advisory committee. Only councillors who are appointed to the committee may vote.
- 4.3.10 Training will be provided to first time Advisory Committee members prior to the first formal meeting of the committee after it is formed and/or reviewed at the commencement of each Council Term.

#### 4.4 Advisory Committee Governance

Advisory Committees are subject to an Instrument of Appointment and Delegation (IoA). There is a standard IoA attached to this policy, and the IoA may be amended slightly, but must be adopted at the time the Committee is formed and/or reviewed at the commencement of each Council Term.

Advisory Committees are assigned a responsible officer by the CEO, to provide administrative support, ensure that the objectives of the IoA are met and to provide support and advice to the Chair in relation to governance. The Officer has no delegated power and is not a voting member of the committee.

Committees are subject to the Shire of Bridgetown-Greenbushes Standing Orders. These Standing orders apply generally to the proceedings of committees, with the exception of;

- a) Clause 9.1 in respect of the requirement to rise;
- b) Clause 9.5 limitation of the number of speeches

#### 4.5 Officer Responsibilities

The nominated responsible officer will;

- Prepare agendas and distribute not less than 3 days before each meeting
- Compile the draft minutes and distribute them to committee members no less than 14 days after the meeting and no less than 7 day prior to the next meeting.
- Compile Council agenda reports outlining all recommendation of the advisory committee to be considered by Council.
- Provide reasonable support to the Advisory Committee through research to assist the Committee with its deliberations. However, work undertaken on behalf of the Advisory Committee will be balanced with other duties assigned to the officer. Where there is insufficient capacity to undertake work on behalf of the Committee, this matter will be referred to the officer's manager for determination of workload priorities.
- Provide the Chair with support and guidance on governance.

#### 4.6 Committee Recommendations

- All actions/proposals made by an Advisory Committee will be taken to Council as recommendations for consideration or to the CEO if the matter can be dealt with under delegated authority or is of an operational nature.

### 5 Applicable Legislation and Documents

<b>Act</b>	Division 2 — Council meetings, committees and their meetings and electors' meetings Subdivision 2 Committees and their meetings of the Local Government Act 1995,
<b>Regulation</b>	Part 2 Council and committee meetings of the Local government (Administration) Regulations 1996
<b>Local Law</b>	Standing Orders Local Law

<b>Shire Policies</b>	M.12 Code of Conduct (Members and Staff) M.13 Anti-Discrimination, Sexual Harassment and Bullying M.20 Establishment of Council Committees M.21 Community Engagement/Consultation Policy A.16 Records Management Policy
<b>Related Documents</b>	Advisory Committee Standard Instrument of Appointment and Delegation
<b>Related Procedure</b>	

## 6 Administration

<b>Original Adoption Date</b>	24 November 2022
<b>Last Reviewed</b>	30 March 2023
<b>Scheduled Reviewed Date</b>	27 April 2023

## 7 Standard instrument of Appointment and Delegation



### **BRIDGETOWN-GREENBUSHES STANDARD ADVISORY COMMITTEE (20XX-20XX)**

#### **INSTRUMENT OF APPOINTMENT & DELEGATION (Excluding Bush Fire Advisory Committee and Local Emergency Management Committee)**

##### 1. Introduction

The Council of the Shire of Bridgetown-Greenbushes (hereinafter called the "Council") hereby establishes a committee under the powers given in Section 5.8, 5.9(2)(c) and 5.17(c) of the Local Government Act 1995, such committee to be known as the Bridgetown-Greenbushes (*Name*) (hereinafter called the "Committee").

The Council appoints to the Committee those persons/organisations whose names appear in section 4.0 below. Membership of the Committee shall, unless otherwise specified, be for a term ceasing on the third Saturday in October in the year the Shire's local government elections are held, after which time the Council may appoint members for a further term.

The Committee shall act for and on behalf of Council in accordance with provisions of the Local Government Act 1995, local laws and policy of the Shire of Bridgetown-Greenbushes and this Instrument.

## 2. Name

The name of the Committee shall be the (*Name*)

## 3. Objectives

The objectives and role of the Committee are:

- 3.1 To advise Council on;
- 3.2 To advise Council on ways to develop and implement (*Document/s*) strategy.

## 4. Membership

- 4.1 Council will appoint minimum of one (1) elected members as Council's representative(s) on the Committee.
- 4.2 Council will appoint a maximum of nine (9) community representatives to reach a maximum membership number not exceeding ten (10) total members number of being:
- 4.3 One CEO appointed shire representative shall be an ex-officio member of the committee and will not be permitted to vote on matters considered by the Committee.

## 5. Presiding Member

The Committee shall appoint a Presiding Member and Deputy Presiding Member to conduct its business. The Presiding Member shall be an Elected Member of Council. The presiding member ensures that minutes of the proceedings are kept and that business is conducted in accordance with the Shire of Bridgetown-Greenbushes Standing Orders.

## 6. Meetings

- 6.1 The Committee shall meet on at least four occasions per year.
- 6.2 Notice of meetings shall be given to members at least 1 prior to each meeting.
- 6.3 If any member is absent from 3 consecutive meetings without leave of the Committee, they shall forfeit their position on such Committee. The Council shall be informed, and will appoint a replacement for the balance of the Committee's term of appointment.
- 6.4 The Presiding Member shall ensure that detailed minutes of all meetings are kept and shall, not later than 14 days after each meeting, provide Council with a copy of such minutes.
- 6.5 All members of the Committee shall have one vote. If the vote of the members present is equally divided, the person presiding may cast a second vote.

## 7. Quorum

Quorum for a meeting shall be at least 50% of the number of offices whether vacant or not.

## 8. Delegated Powers

The Committee is established as an Advisory Committee only and does not have delegated authority to make decisions on behalf of the Council.

## 9. Termination of Committee

Termination of the Committee shall be as at 21 October 2023 or as otherwise specified in the Local Government Act 1995.

10. Amendment to the Instrument of Appointment and Delegation

This document may be altered at any time by the Council on the recommendation of the Committee, or after giving 14 days notice to the Committee.

11. Committee Decisions

Committee decisions shall not be binding on Council if such decisions are in conflict with the delegated powers of the Council.



**BRIDGETOWN-GREENBUSHES ACCESS AND INCLUSION ADVISORY COMMITTEE  
(2021-2023)**

**INSTRUMENT OF APPOINTMENT & DELEGATION**

**1. Introduction**

The Council of the Shire of Bridgetown-Greenbushes (hereinafter called the "Council") hereby establishes a committee under the powers given in Section 5.8, 5.9(2)(c) and 5.17(c) of the Local Government Act 1995, such committee to be known as the Bridgetown-Greenbushes Access and Inclusion Advisory Committee (hereinafter called the "Committee").

The Council appoints to the Committee those persons whose names appear in section 4.0 below. Membership of the Committee shall, unless otherwise specified, be for a term ceasing on the third Saturday in October in the year the Shire's local government elections are held, after which time the Council may appoint members for a further term.

The Committee shall act for and on behalf of Council in accordance with provisions of the Local Government Act 1995, local laws and policy of the Shire of Bridgetown-Greenbushes and this Instrument.

**2. Name**

The name of the Committee shall be the *Bridgetown-Greenbushes Access and Inclusion Advisory Committee*.

**3. Objectives**

The objectives and role of the Committee are:

- 3.1 To advise Council on the establishment of priorities and review of progress on the implementation of the strategies identified in the relevant Disability Access and Inclusion Plan and the Age Friendly Communities Plan.
- 3.2 To formally report to Council annually on the implementation of the Disability Access and Inclusion Plan and the Age Friendly Communities Plan.
- 3.3 To carry out consultation with the community as part of the annual review of the Disability Access and Inclusion Plan and Age Friendly Communities Plan.
- 3.4 To recommend to Council any changes to the priorities identified in the Disability Access and Inclusion Plan and Age Friendly Communities Plan either as part of the annual review process, or if necessary at other times of the year.

**4. Membership**

- 4.1 Council will appoint a minimum of one (1) elected member as Council's representative(s) on the Committee.

- 4.2 Council will appoint a maximum of eight (9) community and service agency representatives, consisting of:
- Margaret Morton
  - Ursula Wade
  - Roberta Waterman
  - Beth Pengelly
  - Marion Gall
  - Jana Mayhew
  - Andrea Mettam
  - Joan Leader
  - John Szolkowski

- 4.3 One CEO appointed shire representative shall be an ex-officio member of the committee and will not be permitted to vote on matters considered by the Committee.

5. Presiding Member

The Committee shall appoint a Presiding Member and Deputy Presiding Member to conduct its business. The Presiding Member shall ensure that minutes of the proceedings are kept and that business is conducted in accordance with the Shire of Bridgetown-Greenbushes Standing Orders.

6. Meetings

The Committee shall meet on at least four occasions per year.

- 6.1 Notice of meetings shall be given to members at least 3 days prior to each meeting.
- 6.2 If any member is absent from 3 consecutive meetings without leave of the Committee, they shall forfeit their position on such Committee. The Council shall be informed, who will appoint a replacement for the balance of the Committee's term of appointment.
- 6.3 The Presiding Member shall ensure that detailed minutes of all meetings are kept and shall, not later than 10 days after each meeting, provide Council with a copy of such minutes.
- 6.4 All members of the Committee shall have one vote. If the vote of the members present is equally divided, the person presiding may cast a second vote.

7. Quorum

The quorum for the Committee shall be at least 50% of the number of offices of committee members, whether vacant or not.

8. Delegated Powers

The Committee is established as an Advisory Committee only and does not have delegated authority to make decisions on behalf of the Council.

9. Termination of Committee

Termination of the Committee shall be:

- a) In accordance with the Local Government Act 1995 (ie; 19 October 2023); or
- b) At the direction of Council

10. Amendment to the Instrument of Appointment and Delegation

This document may be altered at any time by the Council on the recommendation of the Committee, or after giving 14 days notice to the Committee.



11. Committee Decisions

Committee decisions shall not be binding on Council if such decisions are in conflict with the delegated powers of the Council.



**AUDIT COMMITTEE  
[2021-2023]**

**INSTRUMENT OF APPOINTMENT & DELEGATION**

**1. INTRODUCTION**

The Council of the Shire of Bridgetown-Greenbushes (hereinafter called the "Council") hereby establishes a committee under the powers given in Section 5.8, 5.9(2)(a) and 5.16 of the *Local Government Act 1995* (the Act) and *Local Government (Audit) Regulations 1996* (Audit Regs), such committee to be known as the Audit Committee (hereinafter called the "Committee").

The Committee shall act for and on behalf of Council in accordance with provisions of the Act, local laws and policy of the Shire of Bridgetown-Greenbushes and this Instrument.

**2. NAME**

The name of the Committee shall be the *Audit Committee*.

**3. OBJECTIVES OF THE COMMITTEE**

- 3.1 To provide guidance and assistance to the local government in carrying out-
- a) Its functions under Part 6 of the Local Government Act 1995 (*Financial Management*); and
  - b) Its functions relating to other audits and other matters related to financial management; and
  - c) The local government's functions in relation to audits carried out under Part 7 of the Local Government Act 1995 (*Audit*).
- 3.2 To review a report given to it by the CEO under regulation 17(3) of the Local Government (Audit) Regulations 1996 (*CEO to review certain systems and procedures*), and to –
- a) report to Council the results of that review; and
  - b) give a copy of the CEO's report to Council.
- 3.3 To monitor and advise the CEO when the CEO is carrying out functions in relation to a review -
- a) of systems and procedures in relation to risk management, internal control and legislative compliance in accordance with regulation 17(1) of the Local Government (Audit) Regulations 1996; and
  - b) of the local governments financial management systems in accordance with the Local Government (Financial Management) Regulations 1996 regulation 5(2)(c).
- 3.4 To support the auditor of the local government to conduct an audit and carry out the auditor's other duties under the Act in respect of the local government.
- 3.5 To oversee the implementation of any action that the local government -

- a) is required to take by section 7.12A(3) of the Act (Audit report); and
- b) has stated it has taken or intends to take in a report prepared under section 7.12A(4)(a) of the Act; and
- c) has accepted it should be taken following receipt of a report of a review conducted under regulation 17(1) of the Local Government (Audit) Regulations; and
- d) has accepted it should be taken following receipt of a report of a review conducted under the Local Government (Financial Management) Regulations 1996 regulation 5(2)(c).

#### 4. MEMBERSHIP

In accord with s.5.10(4) of the Act the President of the Shire of Bridgetown-Greenbushes may be a member of the committee, provided the President indicates an intention to be such a member at the time the committee is appointed.

- 4.1 Council will appoint four (4) elected members as Council's representatives on the Committee.
- 4.2 Further, the Committee may call upon two independent (senior) consultants with expertise in financial and/or legal matters to provide independent external advice to the Committee. Appointments of external consultants shall be made by CEO following a decision of Council and the allocation of sufficient funds in the budget as guided from professional fee schedules.
- 4.3 No member of staff including CEO may be a member of the Committee.

#### 5. PRESIDING MEMBER

The Committee shall appoint a Presiding Member and Deputy Presiding Member to conduct its business. The Presiding Member shall ensure that minutes of the proceedings are kept and that business is conducted in accordance with the Shire of Bridgetown-Greenbushes Standing Orders.

The Presiding Member, if different from the President, is to refrain from speaking publically on behalf of the Committee or Council, or from issuing any form of written material purporting to speak on behalf of the Committee or Council without the prior approval of the President.

#### 6. MEETINGS

The Committee shall meet at least twice in a financial year. Note, legislation requires that the Committee shall meet with Council's external Auditor at least once during each year of the term of the Committee.

- 6.1 Notice of meetings shall be given to members at least 1 week prior to each meeting.
- 6.2 The Presiding Member shall ensure that minutes of agreed outcomes of all meetings are kept and shall, not later than 10 days after each meeting, ensure that all Councillors are provided with a copy of such minutes.
- 6.3 All members of the Committee shall have one vote and shall vote.
- 6.4 The Committee is to meet as soon as practicable after the annual interim audit report is received in order to address any issues raised by Council's Auditor.

#### 7. QUORUM

Quorum for a meeting shall be 2.

## 8. DELEGATED POWERS

The Committee is a formally appointed Committee of the Council and is responsible to that body. The Committee does not have executive powers or authority to implement actions in areas over which the CEO has legislative responsibility, and does not have delegated financial responsibility.

The Committee does not have any management functions, cannot involve itself in management processes or procedures, and is therefore independent of management.

The Committee is to report to Council and provide appropriate advice and recommendations on matters relevant to its terms of reference. This is in order to facilitate informed decision-making by Council in relation to the legislative functions and duties of the local government that have not been delegated to the CEO.

## 9. DUTIES AND RESPONSIBILITIES

The duties and responsibilities of the Committee will be –

- 9.1 Provide guidance and assistance to Council as to the carrying out of functions of the local government in relation to audits.
- 9.2 Develop and recommend to Council –
  - a list of those matters to be audited; and
  - the scope of the audit to be undertaken.
- 9.3 Support the auditor of the local government to conduct an audit and carry out the auditor's other duties under the *Local Government Act 1995* and ensure that audits are conducted successfully and expeditiously.
- 9.4 Examine the reports of the Auditor after receiving a report from CEO, and invite the Auditor to attend audit committee meetings to discuss audit results. Report to Council those matters raised that require action to be taken by the local government.
- 9.5 Critically appraise and report to Council on any internal or external audit report that raises high level risk management, internal control, financial reporting, and other accountability or governance issues relevant under the Committee's terms of reference.
- 9.6 Monitor the risk exposure of Council by determining if management has appropriate risk management processes and adequate management information systems.
- 9.7 Oversee the implementation of any action resulting from –
  - the auditor's findings;
  - a review of systems and procedures in relation to risk management, internal control and legislative compliance; and
  - a review of the appropriateness and effectiveness of the financial management systems and procedures of the local government.
- 9.8 Recommend to Council the adoption of the annual financial report.
- 9.9 Review issues relating to national competition policy and comparative performance indicators.
- 9.10 Monitor ethical standards and related party transactions by way of determining whether the systems of control are adequate.
- 9.11 Identify and refer specific projects or investigations deemed necessary through CEO, the internal auditor and Council if appropriate. Oversee any subsequent investigations.

9.12 Monitor the progress of any major lawsuits facing the council.

9.13 In the form of minutes or otherwise, report to Council after each meeting.

#### 10. TERMINATION OF COMMITTEE

Termination of the Committee shall be:

- a) in accordance with the Local Government Act 1995 (i.e. 21 October 2023)
- b) at the direction of Council

#### 11. AMENDMENT TO THE INSTRUMENT OF APPOINTMENT AND DELEGATION

This document may be altered at any time by Council on the recommendation of the Committee, or after the giving of 14 days notice to the Committee. Alterations shall not contravene contracts of employment.

#### 12. COMMITTEE DECISIONS

Committee decisions shall not be binding on Council if such decisions are in conflict with the delegated powers of the Council.

Reports and recommendations of each Committee meeting shall be presented to an ordinary or special meeting of the Council.



**CEO PERFORMANCE REVIEW COMMITTEE  
(2021-2023)**

**INSTRUMENT OF APPOINTMENT & DELEGATION**

**1. Introduction**

The Council of the Shire of Bridgetown-Greenbushes (hereinafter called the "Council") hereby establishes a committee under the powers given in Section 5.8, 5.9(2)(a) and 5.16 of the Local Government Act 1995, such committee to be known as the CEO Performance Review Committee (hereinafter called the "Committee").

The Committee shall act for and on behalf of Council in accordance with provisions of the Local Government Act 1995, local laws and policy of the Shire of Bridgetown-Greenbushes and this Instrument.

**2. Name**

The name of the Committee shall be the *CEO Performance Review Committee*.

**3. Objectives**

As directed by Council from time to time, use the performance appraisal system to ensure that its objectives are achieved in a timely and efficient manner and proposes to use the system to recognise and reward high achievement.

**4. Membership**

The Membership of the Committee shall consist of four (4) elected members.

**5. Presiding Member**

The Committee shall appoint a Presiding Member and Deputy Presiding Member to conduct its business. The Presiding Member shall ensure that minutes of the proceedings are kept and that business is conducted in accordance with the Shire of Bridgetown-Greenbushes Standing Orders.

**6. Meetings**

Meetings of the Committee shall be held as required or determined by the Committee Members.

6.1 Notice of meetings shall be given to members at least 1 week prior to each meeting.

6.2 The Presiding Member shall ensure that minutes of agreed outcomes of all meetings are kept and shall, not later than 10 days after each meeting, provide Council with a copy of such minutes.

6.3 All members of the Committee shall have one vote and shall vote.

**7. Quorum**

Quorum for a meeting shall be 2.

8. Delegated Powers

The CEO Performance Review Committee has no delegated authority beyond the objectives outlined in clause 3 of this Instrument.

As a minimum, the Committee will report to Council twice each year.

9. Termination of Committee

Termination of the Committee shall be:

- a) in accordance with the Local Government Act 1995 (i.e. 21 October 2023)
- b) at the direction of Council

10. Amendment to the Instrument of Appointment and Delegation

This document may be altered at any time by the Council on the recommendation of the Committee, or after giving 14 days notice to the Committee. Alterations shall not contravene the contract of employment.

11. Committee Decisions

Committee decisions shall not be binding on Council if such decisions are in conflict with the delegated powers of the Council.



**BRIDGETOWN-GREENBUSHES CULTURAL INCLUSION ADVISORY COMMITTEE  
(2021-2023)**

**INSTRUMENT OF APPOINTMENT & DELEGATION**

1. Introduction

The Council of the Shire of Bridgetown-Greenbushes (hereinafter called the "Council") hereby establishes a committee under the powers given in Section 5.8, 5.9(2)(c) and 5.17(c) of the Local Government Act 1995, such committee to be known as the Bridgetown-Greenbushes Cultural Inclusion Advisory Committee (hereinafter called the "Committee").

The Council appoints to the Committee those persons whose names appear in section 4.0 below. Membership of the Committee shall, unless otherwise specified, be for a term ceasing on the third Saturday in October in the year the Shire's local government elections are held, after which time the Council may appoint members for a further term.

The Committee shall act for and on behalf of Council in accordance with provisions of the Local Government Act 1995, local laws and policy of the Shire of Bridgetown-Greenbushes and this Instrument.

2. Name

The name of the Committee shall be the *Bridgetown-Greenbushes Cultural Inclusion Advisory Committee*.

3. Objectives

The objectives and role of the Committee are:

- 3.1 To advise Council on ways to grow recognition and respect for all cultures.
- 3.2 To advise Council on ways to develop and implement reconciliation actions and strategies.
- 3.3 To advise Council on ways to facilitate the collection and sharing of information and stories about local and culture and history including NAIDOC week events and Harmony Week activities and events.
- 3.4 To advise Council on the development of cultural inclusion events and events calendar.
- 3.5 To advise Council on ways to identify, preserve and showcase significant local history and heritage including promotion of indigenous history.

4. Membership

- 4.1 Council will appoint three (3) elected members as Council's representative(s) on the Committee.
- 4.2 Council will appoint a maximum of seven (7) community representatives being:
  - 1 representative from Bridgetown Historical Society



- 2 representatives from culturally and linguistically diverse populations
- 3 persons that identify as a person of Aboriginal and/or Torres Strait Islander descent
- 1 general community representative

4.3 One CEO appointed shire representative shall be an ex-officio member of the committee and will not be permitted to vote on matters considered by the Committee.

#### 5. Presiding Member

The Committee shall appoint a Presiding Member and Deputy Presiding Member to conduct its business. The Presiding Member shall ensure that minutes of the proceedings are kept and that business is conducted in accordance with the Shire of Bridgetown-Greenbushes Standing Orders.

#### 6. Meetings

6.1 The Committee shall meet on at least four occasions per year.

6.2 Notice of meetings shall be given to members at least 3 days prior to each meeting.

6.3 If any member is absent from 3 consecutive meetings without leave of the Committee, they shall forfeit their position on such Committee. The Council shall be informed, who will appoint a replacement for the balance of the Committee's term of appointment.

6.4 The Presiding Member shall ensure that detailed minutes of all meetings are kept and shall, not later than 10 days after each meeting, provide Council with a copy of such minutes.

6.5 All members of the Committee shall have one vote. If the vote of the members present is equally divided, the person presiding may cast a second vote.

#### 7. Quorum

The quorum for the Committee shall be at least 50% of the number of offices of committee members, whether vacant or not.

#### 8. Delegated Powers

The Committee is established as an Advisory Committee only and does not have delegated authority to make decisions on behalf of the Council.

#### 9. Termination of Committee

Termination of the Committee shall be as at 21 October 2023 or as otherwise specified in the Local Government Act 1995.

#### 10. Amendment to the Instrument of Appointment and Delegation

This document may be altered at any time by the Council on the recommendation of the Committee, or after giving 14 days notice to the Committee.

#### 11. Committee Decisions

Committee decisions shall not be binding on Council if such decisions are in conflict with the delegated powers of the Council.



**YOUTH SERVICES ADVISORY COMMITTEE**  
**INSTRUMENT OF APPOINTMENT & DELEGATION**  
**[2021-2023]**

**1. Introduction**

The Council of the Shire of Bridgetown-Greenbushes (hereinafter called the "Council") hereby establishes a committee under the powers given in Section 5.8, 5.9(2)(c) and 5.17(1)(c) of the Local Government Act 1995, such committee to be known as the Bridgetown-Greenbushes Youth Services Advisory Committee (hereinafter called the "Committee").

The Council appoints to the Committee those persons whose names appear in section 4 below. Membership of the Committee shall, unless otherwise specified, be for a term ceasing on the third Saturday in October in the year the Shire's local government elections are held, after which time the Council may appoint members for a further term.

**2. Name**

The name of the Committee shall be the *Bridgetown-Greenbushes Youth Services Advisory Committee*.

**3. Objectives**

The objectives and role of the committee are:

- 3.1 To provide advice and input into a review of Council's Youth Plan
- 3.2 Once the Youth Plan is reviewed, to provide advice and input into the prioritization of strategies and actions contained in the Youth Plan.
- 3.3 To report to Council at least bi-annually on the implementation of the Youth Plan.

**4. Membership**

- 4.1 Council will appoint two (2) elected members as Council's representative(s) on the Committee.
- 4.2 Council will appoint twelve (12) service agency and community group representatives, being:
  - youth representative from the Blackwood Youth Action Group
  - 1 Community Youth Representative
  - Representative from Bridgetown High School
  - 1 representative from Police
  - 1 representative from Greenbushes Community Resource Centre
  - 1 representative from the justice sector
  - 1 representative from the health sector
  - 1 representative with disability focus or awareness

- 1 representative with an arts and culture focus
- 1 representative with a sport and recreation focus
- 1 representative from the community
- Blackwood Youth Action Coordinator

4.3 One CEO appointed shire representative shall be an ex-officio member of the committee and will not be permitted to vote on matters considered by the Committee.

#### 5. Presiding Member

The Committee shall appoint a Presiding Member and Deputy Presiding Member to conduct its business. The Presiding Member shall ensure that minutes of the proceedings are kept and that business is conducted in accordance with the Shire of Bridgetown-Greenbushes Standing Orders.

#### 6. Meetings

6.1 The Committee shall meet bi-monthly.

6.2 Notice of meetings shall be given to members at least 3 days prior to each meeting.

6.3 If any member is absent from 3 consecutive meetings without leave of the Committee, they shall forfeit their position on such Committee. The Council shall be informed, who will appoint a replacement for the balance of the Committee's term of appointment.

6.4 The Presiding Member shall ensure that detailed minutes of all meetings are kept and shall, not later than 10 days after each meeting, provide Council with a copy of such minutes.

6.5 All members of the Committee shall have one vote. If the vote of the members present is equally divided, the person presiding can cast a second vote.

#### 7. Quorum

The quorum for the Committee shall be at least 50% of the number of offices of committee members, whether vacant or not.

#### 8. Delegated Powers

The Committee is established as an Advisory Committee only, and does not have delegated authority beyond the performance of the tasks allocated to it by Council.

#### 9. Termination of Committee

Termination of the Committee shall be as at 21 October 2023 or as otherwise specified in the Local Government Act 1995.

#### 10. Amendment to the Instrument of Appointment and Delegation

This document may be altered at any time by the Council on the recommendation of the Committee, or after giving 14 days notice to the Committee.

#### 11. Committee Decisions

Committee decisions shall not be binding on Council if such decisions are in conflict with the delegated powers of the Council.



# ROLLING ACTION SHEET

## ROLLING ACTION SHEET

**April 2023 (encompassing Council Resolutions up to Special Council Meeting held 30 March 2023)**

Where a tick is indicated this Item will be deleted in the next update

Note: Where no progress has occurred on implementing a resolution since the last update this comment will be made in the right hand column titled 'Progress Since Last report' but will not be included in the 'Past Comments' column. Only comments detailing specifics of how the resolution is being implemented are contained in the 'Past Comments' column.

Council Decision No.	Wording of Decision	Responsible Officer	Past Comments	Progress Since Last report	√
C.02/1216 Acquisition of Dumpling Gully Precinct	That Council request the CEO to investigate the options of the Shire of Bridgetown-Greenbushes taking ownership of the Dumpling Gully Dams (and associated area) commonly called the Dumpling Gully Precinct to incorporate the area into a Shire Reserve which can be developed for both passive and active recreation activities for the community and to manage and protect the Wetlands and associated unique fauna and flora of the region.	T Clynch	<p>Correspondence forwarded to Water Corporation on 23 December 2016. Response received 28 February 2017 indicating in-principle support to the proposal (April 2017).</p> <p>A meeting was held with the Water Corporation and Talison Lithium on 19.6.17 to further discuss the processes for de-proclamation of the drinking water source and the need to engage with DPAW (July 2017).</p> <p>A meeting is scheduled for 3 September with Water Corporation to progress this matter (September 2018).</p> <p>Advice received from Water Corporation that is continuing to work with Department of Water and Environmental Regulation (DWER) about excising the dam from State Forest (requires Cabinet approval) and resolving the water allocation issues. A follow up meeting with DWER is being planned (October 2018).</p> <p><b>January 2019</b> Refer item in January agenda.</p> <p><b>February 2019</b> Submission lodged with Department of Water and Environmental Regulation recommending that the Greenbushes</p>	<p><b>April 2023</b> No update.</p>	

			<p>Catchment Area should be abolished under the Country Areas Water Supply Act 1947.</p> <p><b>September 2019</b>  DWER is currently conducting stakeholder consultation on the abolition of the Greenbushes Catchment Area under the Country Areas Water Supply Act 1947 on the basis that water quality issues with this source means that it is no longer used by the Water Corporation to supply public drinking water. The DWER recommendation is that the catchment should now be abolished to enable increased recreation, tourism and customary activities.</p> <p><b>October 2019</b>  The process to transfer the land from State Forest is progressing.</p> <p><b>March 2020</b>  The Shire President and CEO had a meeting with the Minister for Environment about growth strategy projects and took the opportunity to ask for an update on transfer of the former Water Corporation dams to the Shire. A response was subsequently received from the Minister advising that DBCA is supportive in-principle of the Shire's request to use the dams for recreation but a number of issues need to be addressed with both the Shire and Water Corporation. A meeting of all parties is to be requested to expedite the matter.</p> <p><b>May 2020</b>  A meeting of relevant agencies is required but hasn't been able to be arranged due to COVID-19. With the current easing of restrictions a meeting is to be scheduled.</p>		
--	--	--	--	--	--

			<p><b>July 2020</b> A meeting with DBCA is being arranged for August.</p> <p><b>August 2020</b> A meeting was held with DBCA to discuss a number of matters including the dumpling gully precinct. This led to an understanding that a meeting with all parties (Shire, DBCA and Water Corporation) needs to be held and this is currently being arranged.</p> <p><b>September 2020</b> A request has been submitted to DBCA for a meeting to be held between Shire, DBCA and Water Corporation to identify issues to enable this proposal to be progressed.</p> <p><b>June 2021</b> A meeting was held last week with an officer of the Water Corporation to discuss any issues precluding transfer of the land to the Shire. All matters have been addressed and the issue is currently with DBCA to progress. An update has been requested from DBCA.</p> <p><b>July 2021</b> Contact has been made with DBCA to arrange a meeting of stakeholders to accelerate the disposal to the Shire of the Dumpling Gully dams.</p> <p><b>July 2022</b> No progress since last report.</p> <p><b>October 2022</b> A meeting is being arranged for mid-November with relevant Government agencies to determine what needs to occur to accelerate the acquisition of the water bodies by the Shire.</p>		
--	--	--	---	--	--

			<p><b>November 2022</b> A meeting of relevant agencies has been scheduled for 7.12.22</p> <p><b>December 2022</b> A multi-agency meeting was meant to be held on 7.12.222 but unfortunately had to be postponed due to some late notice of unavailability of key participants. A revised meeting date in January is being arranged.</p> <p><b>January 2023</b> Revised meeting date yet to be set due to absence of relevant Government staff in January.</p> <p><b>February 2023</b> A new meeting date with Government agency representatives hasn't been established yet.</p> <p><b>March 2023</b> No progress since last report.</p>		
C.09/0521 Access and Inclusion Advisory Committee Membership & Visitor Centre Access	<p>1. That Council direct the CEO to investigate options to increase the accessibility of the current Visitor Centre building.</p> <p>2. That Council endorse the appointment of community member Roberta Waterman to the Access and Inclusion Advisory Committee.</p>	T Clynh	<p><b>June 2021</b> This action is linked to Resolution C.08/0421 Visitor Information Services &amp; Brierley Jigsaw Gallery Outsourcing Business Case with the consultations associated with that resolution informing this issue.</p> <p><b>September 2021</b> Accessibility is a consideration in the current planning being undertaken for the CRC to move to the Visitor Centre.</p> <p><b>October 2021</b> The draft plans for fit out of the visitor centre include retrofitting an automatic sliding door at the entrance.</p> <p><b>November 2021</b> The investigation into improving</p>	<b>April 2023</b> No update.	



			<p>accessibility to the Visitor Centre building are linked to the development of plans for the CRC to relocate to that building.</p> <p><b>December 2021</b> No progress since last report</p> <p><b>January 2022</b> On hold pending further developments in possible redesign of visitor centre building</p> <p><b>February 2022</b> On hold pending further developments in possible redesign of visitor centre building.</p> <p><b>May 2022</b> The fit out plans prepared by the Bridgetown CRC do propose to improve accessibility into the building however those plans have yet to be endorsed by Council. It can be assumed that no matter what changes to the plans may occur the accessibility issues will be addressed however until such time as the plans are endorsed this item will remain on the Rolling Action Sheet.</p> <p><b>June 2022</b> Improving accessibility of the visitor centre will be considered in the proposed building renewal works proposed to occur in 2022/23.</p> <p><b>July 2022</b> No update since last month's report</p> <p><b>September 2022</b> The general matter of upgrade works to the Visitor Centre was discussed at the September Concept Forum. The A/CEO agreed to provide a further briefing to the October forum.</p> <p><b>October 2022</b> No progress since last update.</p>	
--	--	--	---	--

			<p><b>November 2022</b> Deferred pending further discussions with Council in December on building renewal works at visitor centre.</p> <p><b>December 2022</b> Consideration of potential accessibility improvements at the visitor centre are on hold pending future Council decisions on the visitor centre building – expected to occur in January.</p> <p><b>January 2023</b> No change from last month.</p> <p><b>March 2023</b> No progress since last report.</p>		
<p>C.11/0621 Civic Centre Car Park, Steere Street and Stewart Street Precinct</p>	<p>That Council:</p> <ol style="list-style-type: none"> <li>1. Note the submissions received in 2019 as per Attachment 15 and 2020/21 as per Attachment 16.</li> <li>2. Request the Chief Executive Officer to implement the design of Civic Centre Car Park, Steere Street and Stewart Street Precinct as per Attachment 13.</li> <li>3. Authorise the Chief Executive Officer to execute any minor modifications as may be necessary to safely and efficiently implement the project.</li> </ol>	S Alexander	<p><b>August 2021</b> Funds included in 2021/22 budget with work to be scheduled into 2021/22 works program.</p> <p><b>October 2021</b> Some preliminary works for car parking on Stewart Street have recently commenced.</p> <p><b>November 2021</b> The works will occur as part of the 2021/22 road construction program.</p> <p><b>December 2021</b> No progress since last report</p> <p><b>January 2022</b> No progress since last report</p> <p><b>April 2022</b> The works are scheduled to occur as part of the 2021/22 road construction program, weather permitting.</p> <p><b>May 2022</b> Awaiting availability of contractor to undertake new line marking in the Civic</p>	<p><b>April 2023</b> No update since last month's report.</p>	

		<p>Centre car park. The works on Stewart Street and Steere Street will be carried forward to 2022/23 due to limitations in finding contractors and the need to complete grant funded components of the road construction program as a priority.</p> <p><b>June 2022</b> The funding for this project is proposed to be carried forward to 2022/23 due to limitations in finding contractors and the need to complete grant funded components of the road construction program as a priority.</p> <p><b>July 2022</b> No update since last month's report</p> <p><b>August 2022</b> This work will be scheduled into the Shire's 2022/23 road construction program.</p> <p><b>September 2022</b> Design of the works have been completed with the calling for quotes to occur shortly.</p> <p><b>October 2022</b> This project has been scheduled into the 2022/23 construction program. With grant funded projects finalised this project is likely to occur after March 2023.</p> <p><b>November 2022</b> No update since last month's report.</p> <p><b>January 2023</b> Line marking of car park scheduled to occur on 19 January 2023.</p> <p><b>February 2023</b> Car park line marking complete. Contractor yet to be engaged for remainder of works. RFQ to be issued in February.</p> <p><b>March 2023</b> RFQ for remaining works not yet ready.</p>		
--	--	---	--	--

<p>C.02/0721 Review of Local Laws</p>	<p>1. That in accordance with section 3.16(3) of the Local Government Act 1995, Council note and consider the three submissions received in response to its statutory review of Local Laws.</p> <p>2. That in accordance with section 3.16(4) of the Local Government Act 1995 Council resolves to repeal the Pest Plants Local Law.</p> <p>3. That in accordance with section 3.16(4) of the Local Government Act 1995 Council resolves to amend the following Local Laws with reports to be presented to future Council meetings presenting details of the proposed amendments for consideration:</p> <ul style="list-style-type: none"> <li>(i) Activities on Thoroughfares and Trading in Thoroughfares &amp; Public Places Local Law</li> <li>(ii) Cats Local Law</li> <li>(iii) Fencing Local Law</li> <li>(iv) Health Local Law</li> <li>(v) Standing Orders Local Law</li> </ul> <p>4. That in accordance with section 3.16(4) of the Local Government Act 1995 Council resolves to retain without amendment the following Local Laws:</p> <ul style="list-style-type: none"> <li>(i) Bush Fire Brigades Local Law</li> <li>(ii) Cemeteries Local Law</li> <li>(iii) Dogs Local Law</li> <li>(iv) Parking &amp; Parking Facilities Local Law</li> </ul> <p>5. That in accordance with section 3.12 of the Local Government Act 1995 Council resolves to make a Waste Local Law with a report to be presented to a future Council meeting presenting a draft Local</p>	<p>T Clynych</p>	<p><b>September 2021</b> This resolution is being actioned in parts (each Local Law being actioned independently). An item on the repeal of the Pest Plants Local Law is contained in the September Council agenda</p> <p><b>October 2021</b> Report on Pest Plants Repeal Local Law presented to September Council meeting.</p> <p><b>December 2021</b> Pest Plants Repeal Local Law currently being advertised</p> <p><b>February 2022</b> Report on Pest Plants Repeal Local Law will be presented to March Council meeting. Other proposed amendments to local laws as per the resolution will be addressed in turn.</p> <p><b>March 2022</b> Report on Pest Plants Repeal Local Law and Fencing Local Law are included in March Council agenda. Other proposed amendments to local laws as per the resolution will be addressed in turn.</p> <p><b>April 2022</b> Reports on the Pest Plants Repeal Local Law and Fencing Local Law were presented to Council's March meeting.</p> <p><b>May 2022</b> The proposed amendment to the Fencing Local Law will be submitted to the June Council meeting. An enquiry has been submitted to WALGA seeking information to inform the potential change to clause 5.3 of the Property Local Law.</p>	<p><b>April 2023</b> No update.</p>	
---------------------------------------	---	------------------	--	---	--

	<p>Law for consideration.</p> <p>6. In accordance with section 3.16(4) of the Local Government Act 1995 Council resolves to amend the Local Government Property Local Law by reviewing clause 5.3 of the Local Law with a report on this proposed amendment to be presented to future Council meetings.</p>		<p><b>June 2022</b> The proposed amendment to the Fencing Local Law will be submitted to the July Council meeting. A response has been received from WALGA about gender signage on public toilets and further research into this issue is required.</p> <p><b>July 2022</b> The Pest Plants Repeal Local Law 2021 was gazetted on 5 July and is operational from 19 July 2022.</p> <p><b>August 2022</b> No update since last report.</p> <p><b>October 2022</b> Report on Fencing Local law amendment contained in October agenda.</p> <p><b>November 2022</b> Fencing Amendment Local Law being advertised.</p> <p><b>December 2022</b> No update since last month.</p> <p><b>January 2023</b> Report on Fencing Local Law included in January Council agenda.</p> <p><b>February 2023</b> Amendment to Fencing Local Law in progress. Review of Standing Orders Local Law has been deferred as the State Government intends to legislate for standing meeting procedures in the next tranche of legislative changes under the Local Government Amendment Act this year. Amendments to the other 3 local laws will be progressed as resources allow.</p> <p><b>March 2023</b></p>		
--	---	--	---	--	--

			No progress since last report.		
C.11/1221 Review of Plantation Applications Town Planning Scheme Policy	That Council adopt the draft revised Plantation Applications Town Planning Scheme Policy TP.1, as per Attachment 7, and direct the Chief Executive Officer to proceed to public consultation in accordance with Clause 7.6.2 of Town Planning Scheme No.4, with a report and feedback to be presented to a future meeting of Council.	T Clynh	<p><b>January 2022</b> Actioning of this resolution has been deferred to late January due to the commencement of the new Senior Planner in mid-January</p> <p><b>February 2022</b> Advertising to commence next week with closing date for submissions being 23 March 2022.</p> <p><b>March 2022</b> Submission period ends 23.3.22 after which a report will be prepared for either the April or May Council meeting.</p> <p><b>April 2022</b> Submissions being assessed.</p> <p><b>June 2022</b> No update from last report</p> <p><b>July 2022</b> Due to workload associated with development applications the relevant officer hasn't been able to progress the assessment of the submission received on the draft policy. The matter will be presented to Council in next 2 months.</p> <p><b>August 2022</b> No update since last report.</p> <p><b>February 2023</b> The focus over the last 6 months has been to progress the consolidation of Town Planning Schemes 3 and 4. A report on that matter is contained in the February Council agenda. Once the consolidated TPS is adopted for community consultation all existing town planning scheme policies (including the Plantations Policy) will be</p>	<p><b>April 2023</b> No update.</p>	

			<p>reviewed. In the case of the Plantations Policy this is likely to mean that the review process will recommence from the start.</p> <p><b>March 2023</b> No update.</p>	
<p>C.04/0322 Consideration of Recommendation from Annual General Meeting of Electors – Bridgetown CBD Parking</p>	<p>That Council:</p> <ol style="list-style-type: none"> <li>1. Conducts a review of the parking situation in the Bridgetown CBD, incorporating street parking and off-road parking, including loading bays.</li> <li>2. Request the CEO to assess the capacity of Ranger Services to conduct parking patrols on a regular but infrequent basis, with emphasis on illegal parking and report back via the review of the Workforce Plan due to be completed by June 2022.</li> <li>3. Request the CEO to investigate the area in front of Westpac Bank for provision of a disabled parking bay.</li> </ol>	T Clynch	<p><b>April 2022</b> Not commenced</p> <p><b>June 2022</b> Preliminary assessment of the footpath in front of the Westpac Bank has occurred and concept plans are being prepared.</p> <p><b>July 2022</b> No update since last month's report</p> <p><b>August 2022</b> The parking review hasn't commenced however investigations into establishing an ACROD bay on the footpath in front of the Westpac Bank have occurred and a draft plan and cost estimate was presented to the August Concept forum. Funding of third project is provided for in the draft 2022/23 budget.</p> <p><b>September 2022</b> No update since last report.</p> <p><b>October 2022</b> This item has yet to be progressed. Shire Executive are currently determining the scope of the parking review to determine if it should be done internally or outsourced to a consultant.</p> <p><b>November 2022</b> No update since last month's report.</p> <p><b>February 2023</b> The issue of parking checks being conducted will be addressed in the Workforce Plan which is currently being</p>	<p><b>April 2023</b> Detailed design for the parking bay is being finalised with MRWA after its earlier approval of the concept design. As soon as this is finalised this part of the project will be implemented as soon as a contractor can be engaged.</p>

			<p>drafted. The disabled parking bay plans have been approved by Main Roads WA and we are now seeking quotes from a contractor. The review of the parking situation, has not occurred yet.</p> <p><b>March 2023</b> No update.</p>		
<p>C.06/0322a Consideration of Recommendation from Annual General Meeting of Electors – Access to Rail Corridor</p>	<p>That Council:</p> <ol style="list-style-type: none"> <li>1. Direct the CEO to engage with the Public Transport Authority requesting consideration towards introducing measures to increase fire access for fire crews along the railway corridor within the Shire of Bridgetown-Greenbushes</li> <li>2. Request the Public Transport Authority conduct a higher degree of fire mitigation works on railway reserves within the Shire of Bridgetown-Greenbushes.</li> </ol>	T Clynch	<p><b>April 2022</b> Not commenced</p> <p><b>May 2022</b> Photographic evidence of need for fire mitigation works and mapping is being prepared in order to support the requests to the PTA.</p> <p><b>June 2022</b> A meeting has been held with a consultant acting for Arc Infrastructure about possible enhanced mitigation works on the railway reserve.</p> <p><b>July 2022</b> No update since last report.</p> <p><b>February 2023</b> The approach taken to date with Arc Infrastructure hasn't yielded any feedback therefore it is intended to write directly to the Public Transport Authority (PTA) raising the issue of mitigation. The letter will include a request for PTA to engage with Arc Infrastructure on the issue.</p> <p><b>March 2023</b> No update.</p>	<p><b>April 2023</b> No update.</p>	
<p>C.05/0422 Stanifer Street 40km/h Speed Zone</p>	<p>That a request be submitted to Main Roads Western Australia seeking a reduction in the speed limit to 40km/h on Stanifer Street from just east of its intersection with George Street to just west of its</p>	S Alexander	<p><b>May 2022</b> Traffic counter has been setup on Stanifer St and will record data for 2 weeks.</p> <p><b>June 2022</b></p>	<p><b>April 2023</b> No update since last month's report</p>	



	<p>intersection with Diorite Street with this reduced speed limit being in place until such time as the proposed heavy haulage access road between South Western Highway and the Talison Lithium Mine site is constructed and operational.</p>		<p>Traffic counter data being processed for submittal to MRWA.  <b>July 2022</b>  Request submitted to MRWA  <b>September 2022</b>  No update since last month's report.  <b>October 2022</b>  Waiting for a decision from MRWA on the application.  <b>November 2022</b>  Waiting for a decision from MRWA on the application  <b>December 2022</b>  No update since last month's report  <b>January 2023</b>  Still awaiting decision from MRWA.  <b>February 2023</b>  Contacted MRWA for an update. Waiting for a response.  <b>March 2023</b>  No update from MRWA received. MRWA have previously reported that they have a significant backlog of such requests and the timeframe for assessment may be up to 12 months.</p>		
<p>C.17/0422  Nairnup Road  Land Acquisition</p>	<ol style="list-style-type: none"> <li>1. Direct the CEO to commence formal negotiations with the owners of Lot 7919 Tweed Road, Glenlynn, for the purchase of a 486 sq. m portion of this lot, for the purpose of creating a new alignment for a portion of Nairnup Road.</li> <li>2. Note a further report be presented to Council on the conclusion of this negotiation.</li> </ol>	<p>S Alexander</p>	<p><b>May 2022</b>  Letter posted to land owners  <b>June 2022</b>  Awaiting response from land owners.  <b>July 2022</b>  Letter response period has expired with no response received.  <b>August 2022</b>  No update since last month's report  <b>September 2022</b></p>	<p><b>April 2023</b>  Inspected the location and noted that the fence encroaching into the road reserve has been removed to allow for harvesting of bluegums. Harvesting appears to have been completed some time ago. Still unable to make contact with the landowner to determine their plans.</p>	

			<p>No response received from property owners. Report scheduled for October council meeting to progress the matter.</p> <p><b>October 2022</b> Report to be presented to November Council meeting.</p> <p><b>November 2022</b> Currently confirming correct legal process with a view to begin compulsory land acquisition.</p> <p><b>December 2022</b> Some further issues require addressing prior to reporting back to Council. Report proposed to be presented to Council in January.</p> <p><b>January 2023</b> Report scheduled for February Council Meeting.</p> <p><b>February 2023</b> Waiting on advice from the Department of Planning Lands and Heritage to inform the report. Report to be submitted to a future council meeting.</p> <p><b>March 2023</b> Feedback from DPLH received regarding the process. Preliminary assessment and investigation is required by DPLH.</p>	
C.13/0522 Geegelup Mountain Bike Trail Network and Bridgetown Tourism App	<p>That Council:</p> <ol style="list-style-type: none"> <li>1. Endorse the recommendation from its Trails Development Advisory Committee to proceed with the planning of the Geegelup Mountain Bike Trail Network.</li> <li>2. Note the estimated cost of the planning of the Geegelup Mountain Bike Trail Network is \$50,000 (ex-GST).</li> <li>3. Accept the \$25,000 (ex GST) external funding</li> </ol>	M Richards	<p><b>May 2022</b> Consultant has been appointed.</p> <p><b>July 2022</b> Awaiting commencement of work by consultant.</p> <p><b>August 2022</b> A RFQ including project scope has been sent to three trail designers. Awaiting responses.</p>	<p><b>April 2023</b> DBCA continue to work through their flora and fauna assessment process for the parcel of land identified as the location of the 20km ride park.</p>

	<p>from the Department of Local Government Sport and Cultural Industries to cover one-half the cost of planning the Geegelup Mountain Bike Trail Network to the point of detailed design.</p> <ol style="list-style-type: none"> <li>4. Fund its contribution to the planning of the Geegelup Mountain Bike Trail Network project by transferring the sum of \$25,000 from the Trails Reserve.</li> <li>5. In light of Parts 1-4 above, approve a 2021/22 budget amendment by increasing the 'materials and components' allocation for Account 31RA (Local Community Trails &amp; Paths Projects) from \$23,243 to \$73,243.</li> <li>6. Note the results of the investigation into the development of a Shire specific Tourist App and determine not to proceed with this project at this time.</li> <li>7. Include the \$50,000 expenditure for the planning of the Geegelup Mountain Bike Trail Network in the financial summary pages of the new Corporate Business Plan 2022-26.</li> </ol>		<p><b>September 2022</b> RFQs have been sent out to 3 of the reputable trail development organisations including 2 in the South West. We are waiting to receive response.</p> <p><b>October 2022</b> The three consultants have been in consultation with the Shire to discuss the RFQ with submissions expected to be received for consideration by the end of October.</p> <p><b>November 2022</b> RFQ's being assessed.</p> <p><b>December 2022</b> Magic Dirt Trailworx has been engaged to undertake the planning work associated with this project. An initial meeting to discuss the job is planned before the end of December 2022.</p> <p><b>January 2023</b> Organising initial meeting as consultants were unable to make a time prior to the Christmas break.</p> <p><b>February 2023</b> DBCA, Magic Dirt Trail Worx, representatives of the Bridgetown Mountain Bike and Cycling Club met to complete the first site visit and begin the auditing process. The consultants and DBCA identified a location to build 20km of marketable mountain bike trails in the Hester – the existing trails are mainly located on firebreaks and old DBCA road. The consultant suggested that the existing trails are not worth investing money into – sign and promote to local riding groups now. The 20km of new trail will bring visitors and will be marketable to mountain bike enthusiast.</p>		
--	--	--	--	--	--

			<p><b>March 2023</b>          DBCA are currently working through their assessment process for the parcel of land identified as the location of the 20km ride park.</p>	
<p>C.09/0622          (Parts 3-5)          Review of Finance Policies</p>	<p>That with respect to Section 3 (Finance) of the Policy Manual Council:</p> <p>3. Note that a separate review of Policy F.1 (Community Grants, Service Agreements, Donations and Contributions) and Policy F.9 (Service Agreements for community Service Providers) is to occur with both policies being incorporated into a new single policy.</p> <p>4. Note that a separate review of Policy F.6 (Purchasing Policy) and Policy F.14 (Buy Local Policy) is to occur with both policies being incorporated into a new single policy.</p> <p>5. Note that separate reviews of the following policies is to occur:</p> <ul style="list-style-type: none"> <li>•Policy F.7 (Reporting Forecast Budget Variations Policy)</li> <li>•Policy F.15 (Asset Management)</li> <li>•Policy F.18 (Self-Supporting Loans to Shire Community/Sporting Groups)</li> <li>•Policy F.19 (Assets Financing and Borrowings)</li> <li>•Policy F.21 (Risk Management)</li> </ul>	T Clynych	<p><b>July 2022</b>          Preliminary work has been undertaken on a proposed new Budget Management policy to replace the existing policy F.7 (Reporting Forecast Budget Variations). The proposed policy parameters will be considered by the Audit Committee at its next meeting.</p> <p><b>August 2022</b>          No update since last month's report.</p> <p><b>September 2022</b>          The Audit Committee considered parameters for a new budget management policy. A draft Budget Management Policy will be included in the November agenda. This policy will replace Council's current policy F.6 Reporting Forecast Budget Variations Policy.</p> <p><b>October 2022</b>          Report to Council scheduled for November.</p> <p><b>November 2022</b>          Budget Management Policy to be presented to Council In December. Other policies to be progressed in time.</p> <p><b>December 2022</b>          Budget Management Policy included in December Council agenda.</p> <p><b>January 2023</b>          Due to other priorities in finance area the standalone review of nominated policies</p>	<p><b>April 2023</b>          No update.</p>

			<p>hasn't commenced. Also awaiting updates from DLGSC on ratio reporting before review of Policies F.15 and F.19 can occur.</p> <p><b>February 2023</b></p> <p>No update since last month's report.</p>		
C.11/0622 Verge Information Sheet	<p>That the decision to prepare a Verge Information Sheet made by Council on 26 May 2022 be revised as follows;</p> <ol style="list-style-type: none"> <li>1. The current Council Policies on Street trees, Crossovers and Verge development be reviewed as a matter of priority.</li> <li>2. On completion of the reviews referred to above, a series of Verge Information Sheets be prepared relating to the various aspects of verge management (including but not limited to the matters referred to in the decision of 26 May 2022) for the purpose of providing clear information to residents.</li> </ol>	P St John	<p><b>July 2022</b></p> <p>Internal review of current policies has commenced.</p> <p><b>August 2022</b></p> <p>No update since last report.</p> <p><b>September 2022</b></p> <p>Further report scheduled for the October council meeting.</p> <p><b>October 2022</b></p> <p>This is planned to be presented to Council in November 2022.</p> <p><b>November 2022</b></p> <p>Some further discussion regarding the directions of the proposed policy were held at the November Concept Forum with the intent being to submit a draft policy to the December Council meeting.</p> <p><b>December 2022</b></p> <p>The draft Verge Management Policy has been completed but has to be considered in the context of the planned levels of service review for parks maintenance.</p> <p>Further discussion on verge management issues is scheduled for the January Concept Forum.</p> <p><b>January 2023</b></p> <p>Discussion occurred at January Concept Forum. Draft policy to be presented to February Council meeting.</p> <p><b>February 2023</b></p> <p>Refer item in February Council agenda</p>	<p><b>April 2023</b></p> <p>No update since last report</p>	

			<p>relating to a new verge policy.</p> <p><b>March 2023</b></p> <p>Following adoption of the Verge Policy in February 2023, information material that is informed by the Policy will be prepared. This will occur over the next 2-3 months.</p>	
<p>C.12/0722 Greenbushes Community Bus Pilot Program</p>	<p>That Council endorses the return of the Council funded fortnightly Greenbushes Bus Service to Bridgetown for a trial period of 3 months.</p>	<p>M Richards</p>	<p><b>August 2022</b></p> <p>Planning for recommencement of the bus service is occurring.</p> <p><b>September 2022</b></p> <p>This will begin in October once the bus driver is available.</p> <p><b>October 2022</b></p> <p>The 3 month trial period began on the 13 October with the first bus run from Greenbushes attracting 2 Greenbushes residents.</p> <p><b>November 2022</b></p> <p>Trial in progress.</p> <p><b>December 2022</b></p> <p>Trial still occurring, however Gabriel was unable to attend the December run.</p> <p><b>January 2023</b></p> <p>Trial still ongoing.</p> <p><b>February 2023</b></p> <p>The final Greenbush Bus Run of the trial will occur this month and a report will be provided to Council at the March Council meeting.</p> <p><b>March 2023</b></p> <p>A report will go to April Council meeting for consideration on the outcomes of the trial and whether to continue the bus run.</p>	<p><b>April 2023</b></p> <p>Due to issues around the promotion of the bus run dates and community feedback Councillors informally supported a second trial given the need to fairly assess if the service valued by the Greenbushes community. The dates of the second bus trial are;</p> <p>April 20 May 4 May 18 June 1 June 15 June 29 July 13 July 27</p> <p>These dates have been promoted on the facebook page, posters around Greenbushes and flyers are available from Greenbushes CRC for patrons to refer to.</p>
<p>C.13/0922 Standardised</p>	<p>3. Request the CEO to investigate the design, cost and method of installing a visual Acknowledgement</p>	<p>M Richards</p>	<p><b>October 2022</b></p> <p>Council supported the recommendation to</p>	<p><b>April 2023</b></p> <p>No update since last month the</p>

<p>Acknowledgement of Country</p>	<p>of Country to be included on the main glass entrance doors of the Bridgetown Leisure Centre and the Bridgetown Library, the glass door of the customer support area of the administration building, and appropriately at the Visitor Centre, with a report back to Council.</p>		<p>investigate a method for including a visual Acknowledgement of Country on the entrance doors of the Library, Leisure Centre, Visitor Centre and the doors to the customer service area of the administration building.</p> <p><b>November 2022</b> Discussions with prospective contractors occurring.</p> <p><b>December 2022</b> No update since last month.</p> <p><b>March 2023</b> No update since last month the committee agreed to wait until next financial year as there is a limited budget for NAIDOC week activities.</p>	<p>committee agreed to wait until next financial year to develop the visual Acknowledgements of Country for each of the shire facilities as there is a limited budget for NAIDOC week activities.</p>	
<p>C.02/1022 Proposed Amendment to Local Law Relating to Fencing</p>	<p>That Council give local public notice of its intention to make a Shire of Bridgetown-Greenbushes Amendment Local Law Relating to Fencing 2022 as contained in Attachment 1 and also give notice of this intention to the Minister responsible for Local Government. The purpose of the Shire of Bridgetown-Greenbushes Amendment Local Law Relating to Fencing 2022 is to introduce new requirements for licensing of an electrified fence on a commercial or industrial lot and the effect is that any electrified fence on a commercial or industrial lot is to be located on the property side of the fence, and behind a sufficient fence.</p>	<p>N Price</p>	<p><b>November 2022</b> No update since last report.</p> <p><b>January 2023</b> Item being presented to January 2023 Council meeting.</p> <p><b>February 2023</b> Item presented to Council meeting 25/1/23. Public advertising commenced 15/2/23 and closes 31/3/23.</p> <p><b>March 2023</b> No update since last report.</p>	<p><b>April 2023</b> Public submissions have closed. Report to be presented to the May meeting of Council.</p>	

<p>C.08/1022 Speed Limit – Whittells Road</p>	<p>That Council request the Chief Executive Officer submit an application to Main Roads Western Australia seeking the introduction of a 60kph speed zone on Whittells Road from Railway Terrace to Sunridge Drive. s</p>	<p>S Alexander</p>	<p><b>November 2022</b> Yet to be actioned. Application is planned to be submitted by the end of November.</p> <p><b>December 2022</b> MRWA needs to look at the surrounding roads and consider if they should also be speed zoned. Site visit booked for Thursday 8<sup>th</sup> December to access this.</p> <p><b>January 2023</b> MRWA performed a site visit in December. Now awaiting feedback from MRWA.</p> <p><b>February 2023</b> Waiting for MRWA decision.</p> <p><b>March 2023</b> No update since last report.</p>	<p><b>April 2023</b> No update since last month's report</p>	
---	--	--------------------	--	--	--



<p>C.09/1022 Cultural Inclusion Advisory Committee Recommendations</p>	<p>3. Agree, in principle, to the dual naming of the Blackwood River to include the Aboriginal name – Goorbilyup</p> <p>4. Progress the dual naming process by agreeing to;</p> <p>a) Consult with each of the Shires along the Blackwood River (West Arthur, Boyup Brook, Nannup and Augusta Margaret River).</p> <p>b) Consult with the Aboriginal Elders representing each of the language groups located along the Blackwood River (Wadandi, Pibulmun, Kaneang and possibly Wilman)</p> <p>c) Consult with the Aboriginal Corporations representing each of the language groups along the Blackwood River if required</p> <p>5. Present back to Council for final determination</p>	<p>M Richards</p>	<p><b>November 2022</b> Implementation of this resolution has been delayed by other work priorities for the relevant officer but will be actioned in December.</p> <p><b>December 2022</b> Letters prepared to other local governments regarding dual naming of Blackwood River.</p> <p><b>January 2023</b> Letters were sent in December 2022 to each of the Shire CEO's along the Blackwood River. Officers are waiting to receive responses. The local Aboriginal Elder has been engaging with other Elders across the region regarding the dual naming of the Blackwood River.</p> <p><b>February 2023</b> Acknowledgements received from Shires of West Arthur and Augusta Margaret River noting that their formal consideration will occur by the end of February with responses to be provided shortly thereafter.</p> <p><b>March 2023</b> We have received a letter of support from the Shire Council of West Arthur. I have been in contact with The Shire of Augusta Margaret River and they are currently working through their process. Boyup Brook have discussed the project but are yet to formally present it to Council and Officers will contact Nannup to request feedback.</p>	<p><b>April 2023</b> CEO has received support from the CEO at the Shire of Nannup. I have sent the support letter from the Undalup Association (First nations Custodians from Nannup, Margaret River and Bridgetown).</p>	
<p>C.02/1122 Petition – Greenbushes</p>	<p>That Council;</p> <p>1. Receive the petition</p> <p>2. Note its intent to review parks and gardens service levels and this will include an assessment of the</p>	<p>T Clynh</p>	<p><b>January 2023</b> Work on reviewing parks and gardens service levels has commenced.</p>	<p><b>April 2023</b> No update.</p>	

Depot and Worker	<p>service levels for the Greenbushes locality and an assessment of employee resources to achieve those service levels</p> <p>3. Note that the placement of staff such as locality and facility is an operational responsibility of the Chief Executive Officer and not a decision of the Council</p> <p>4. Note the intent of the Chief Executive Officer to investigate the advantages and disadvantages of establishing a sub-works depot at Greenbushes as part of the planning for redevelopment of the Shire Depot buildings that were destroyed in the February 2022 bushfire.</p>		<p><b>February 2023</b> Work on reviewing parks and gardens service levels is progressing.</p> <p><b>March 2023</b> Council workshop was held 13 March 2023 for initial discussions on service levels.</p>		
C.03/1122 Review of Infrastructure Policies	<p>That with respect to Section 4 (Infrastructure) of the Policy Manual, Council:</p> <p>1. Endorse the following Policies with modifications as shown in Attachment 2:</p> <ul style="list-style-type: none"> <li>• Policy I.2 (Provision of Roads and Associated Civil Works for Subdivisions and Developments)</li> <li>• Policy I.5 (Road Resumptions)</li> <li>• Policy I.6 (Exploration Drilling on Shire Roads and Reserves)</li> <li>• Policy I.9 (Private Works Plant and Equipment Accessed by Shire Staff)</li> <li>• Policy I.13 (Gravel Road Development &amp; Maintenance)</li> <li>• Policy I.14 (Restricted Access Vehicles – Applications for Council Support)</li> <li>• Policy I.15 (Lawn Cemetery – Reservation of Grave Sites)</li> <li>• Policy I.17 (Pesticides Spraying)</li> <li>• Policy I.19 (Gravel Procurement)</li> </ul> <p>2. Note that review of Policy I.1 (Street Trees), Policy I.4 (Road Verge, Policy), I.7 (Crossovers), and Policy I.8 (Temporary Closure of a Road for an Event) are deferred for standalone process due to the scope of changes required</p> <p>3. Note and retain all other policies without</p>	S Alexander	<p><b>January 2023</b> Standalone review of Policies I.1, I.4, I.7 and I.8 are yet to commence.</p> <p><b>February 2023</b> No change since last report.</p> <p><b>March 2023</b> No update since last report.</p>	<p><b>April 2023</b> No update since last month's report</p>	

	modification.			
C.04/1122 Review of Policy Manual Section 9 – Other	<p>That with respect to Section 9 (Other) of the Policy Manual, Council:</p> <ol style="list-style-type: none"> <li>1. Endorse the following Policies with minor modifications as shown in Attachment 3: <ul style="list-style-type: none"> <li>• O.1 Vandalism</li> <li>• O.2 Policy for Allowing Functions in Shire Reserves or Parks</li> <li>• O.3 Procedures for Adopting New Sites/Properties for Inclusion in the Municipal Inventory</li> <li>• O.5 Provision of Refreshments to Firefighters by Incident Controller</li> <li>• O.14 Australia Day Events</li> </ul> </li> <li>2. Revoke Policy O.7 (Genetically Modified Organism (GMO) Free Zone) and renumber all policies accordingly</li> <li>3. Note and retain all other policies without modification</li> <li>4. Note that the following policies will be subject to standalone review in 2022/23: <ul style="list-style-type: none"> <li>• O.8 Bridgetown-Greenbushes Visitor Centre Membership</li> <li>• O.9 Bush Fire Brigade Personal Protective Equipment</li> <li>• O.11 Use of Chainsaws by Bush Fire Brigades</li> <li>• O.15 Fire Protection – Shire or Brigade Owned Fire Fighting Appliances.</li> </ul> </li> </ol>	T Clynych	<p><b>January 2023</b> Review of Policy O.8 will occur after completion of a 'review of visitor servicing' currently being undertaken. Review of Policies O.9, O.11 and O.15 is currently being considered by a sub-group of fire control officers.</p> <p><b>February 2023</b> No change since last report.</p> <p><b>March 2023</b> BFAC has endorsed new procedures which are currently being reviewed before presentation to Council.</p>	<p><b>April 2023</b> No update.</p>
C.08/1122 Land Untidy – Lot 69, 38 Warner Street Hester	<p>That Council;</p> <ol style="list-style-type: none"> <li>1. Instruct the CEO to take legal action against the owner of Lot 69, 38 Warner Street Hester in accordance with Section 3.25 of the Local Government Act to remedy that the subject land is untidy; and</li> <li>2. Authorise the CEO to engage a solicitor to prepare legal documents and represent the local government in court.</li> </ol>	L Guthridge	<p><b>January 2023</b> Contact has been made with the property owner and some clean-up work has commenced by that owner.</p> <p><b>February 2023</b> Progress for clean-up is slow. Staff will activate legal action if clean up not resolved by the end of February 2023.</p> <p><b>March 2023</b></p>	<p><b>April 2023</b> Clean-up is progressing</p>

			Clean-up is progressing.		
C.14/1222 Amendment No 71 to Town Planning Scheme No 4 – Proposed Additional Use – Motor Vehicle Repairs – Lot 48 (37) Jephson Street Greenbushes	That Council: 1. Resolve to initiate and advertise Amendment No. 71 to the Shire of Bridgetown- Greenbushes Town Planning Scheme No. 4 to include “Additional Use A7” into ‘Schedule 4 Additional Uses’ to make Motor Vehicle Repair Station a discretionary use on Lot 48 Jephson Street, Greenbushes and amend the Scheme Map accordingly 2. Instruct the CEO to prepare amendment documents for Amendment No. 71 to the Shire of Bridgetown- Greenbushes Town Planning Scheme No. 4 3. When the amendment is advertised, in addition to the other forms of advertising, a notification letter be sent to all owners and occupiers of properties falling within a 200 metre radius of the boundary of the subject land 4. Determine that the amendment is a “Standard Amendment” pursuant to Part 5, Division 1, 35(2) of the Planning and Development (Local Planning Schemes) Regulations 2015 as the Amendment is not a complex or basic amendment for the reason that the Amendment that would have minimal impact on land in the scheme area that is not the subject of the Amendment and does not result in any significant environmental, social, economic or governance impacts on land in the scheme area, on the basis that the additional use being proposed is one that can be considered at the Council’s discretion.	L Guthridge	<b>December 2022</b> Amendment documents referred to the EPA for assessment in accordance with Section 48A of the EP Act. <b>January 2023</b> EPA confirmed that additional information required to enable the EPA to assess the Amendment relating to impacts of the proposal on social surrounds and inland waters given the nature of the land use proposal subject of the amendment. <b>February 2023</b> The EPA has confirmed that it will not formally assess the Amendment. Shire staff to commence the advertising process. <b>March 2023</b> The Amendment is being advertised with the advertising period ending 4 <sup>th</sup> April 2023.	<b>April 2023</b> Advertising is complete. A report will be presented to Council at its May 2023 meeting to consider the submissions and make a recommendation to the WAPC to either to adopt for final approval or refuse the Amendment	
C.16/1222 Land Untidy – Lot 32, 12 Connell Street Hester	That Council authorise the CEO to; 1. Serve notice in accordance with the Local Government Act 1995 to clean up and remediate Lot 32, 12 Connell Street Hester from all miscellaneous building debris contaminated by asbestos containing material resulting from fire 2. In the event that the notice is not complied with, take all necessary steps to ensure that clean up	L Guthridge	<b>January 2023</b> The owner will be contacted to explain the process of legal action if the owner does not clean up property.  The Shire recently arranged for airborne asbestos monitoring at the site (results	<b>April 2023</b> No update.	

	<p>and remediation of Lot 32, 12 Connell Street Hester is undertaken</p> <p>3. Recover all costs from the owner incurred by the Local Government in executing part 2 of this resolution.</p>		<p>pending) to get a gauge of the health risk for people living in the area.</p> <p><b>February 2023</b> Attempts to contact the owner via phone and site visit has been unsuccessful. Formal letter will be prepared to invite the owner to discuss options with Shire staff.</p> <p>Airborne testing for asbestos has concluded and the results reveal a very low risk to human health and are below the limits of reporting (LOR).</p> <p><b>March 2023</b> An order has been issued to the landowner to clean up by the 12 May 2023.</p>	
C.11/0123 Public Open Space Strategy	<p>1. The Corporate Business Plan project named as 'Playground Strategy' be renamed as 'Parks Facilities Plan'</p> <p>2. Council note the methodology and outcomes of the project as contained in Attachment 10.</p>	P St John	<p><b>February 2023</b> Not actioned yet.</p> <p><b>March 2023</b> No further update – this project is planned for 2023/24 FY.</p>	<p><b>April 2023</b> No further update – this project is planned for 2023/24 FY</p>
SpC.02/0223 RFT01 - 22/23 Design and Construct of Greenbushes Car Park	<p>That Council:</p> <p>1. Award Tender RFT01 – 22/23 'Design and Construct of Greenbushes Car Park' to BCP Contractors Pty Ltd (ABN: 24 602 859 405) and authorises the Chief Executive Officer to finalise and execute a contract to complete the works in accordance with BCP Contractors Pty Ltd's tender, inclusive of both separable portions A and B (with Separable Portion B subject to PTA approval of the design to the satisfaction of the Shire) for the lump sum price of \$568,420.57 (ex. GST).</p> <p>2. Amend its 2022/23 budget as follows:</p> <p>i. Transfer an amount of \$51,864 from the Strategic Projects Reserve to fund the additional expenditure of the Greenbushes CBD Parking &amp; Safety Enhancement Project.</p> <p>ii. Expenditure Account 1410040 Job No. CP05</p>	T Clynych	<p><b>February 2023</b> Contract being prepared for BCP Contractors Pty Ltd.</p> <p><b>March 2023</b> Contract completed and signed. Kick of meeting held with contractor.</p>	<p><b>April 2023</b> Commencement of construction is imminent.</p>

	<p>'Major Strategic Project Greenbushes CBD Parking &amp; Safety Enhancement Project' – increase by \$57,624 from \$610,796 to \$668,420.</p> <p>iii. Income Account 1414130 'Car Park Grants &amp; Contributions' – increase by \$7,760 from \$605,282 to \$613,042.</p>			
SpC.03/0223 Greenbushes Youth Precinct Detailed Design and Construct RFQ Acceptance	<p>That Council:</p> <ol style="list-style-type: none"> <li>1. Accept the proposal from Skate Sculpture dated 1 February 2023 for the detailed design and construction of elements of the Greenbushes Youth Precinct (stage 1) including Skate Park, Quarter Basketball Court, Shelter and Outdoor Furniture in accordance with the Greenbushes Youth Precinct Plan and Report for the contract value of \$483,104.70</li> <li>2. Authorise the Chief Executive Officer to negotiate cost elements of the contract as long as the total value of the contract does not exceed \$483,105 Amend the 2022/23 budget by; <ol style="list-style-type: none"> <li>i. increasing the expenditure allocation of Job No. 22IN 'Major Strategic Project – Greenbushes Youth Precinct' by \$33,105, from \$450,000 to \$483,105</li> <li>ii. increasing income in account 1344530.92 'Other Recreation and Sport Contributions/Reimbursements' by \$160,000 from \$191,564 to \$351,564</li> <li>iii. decreasing income in account 1344230.65 'Other Recreation and Sport Grants' by \$125,000 from \$283,164 to \$158,164</li> </ol> </li> <li>3. Determine that, in the event that a third party contribution of less than \$160,000 is received for this project by 31 March 2023, that the funding shortfall be allocated from the Strategic Projects Reserve, and that a formal budget amendment report to ratify this will be prepared at that time should this be necessary</li> <li>4. Transfer an amount up to \$35,000 from the</li> </ol>	M Richards	<p><b>March 2023</b></p> <p>The Skate Sculpture have been engaged to complete the Greenbushes Youth Precinct stage 1. Site possession and demolition is scheduled to start mid April. Letters to residents close to the construction site will be notified of the potential disturbances that may occur during construction.</p>	<p><b>April 2023</b></p> <p>Site possession took place on the 12 April. Safety fencing of the area and demolition of the existing infrastructure has been completed. Letters to neighbouring residents have been sent, and posters with the works schedule have been provided to Greenbushes CRC for display around Greenbushes, inclusion in the Greenbushes Baliningup Newsletter and inclusion on the Greenbushes CRC FB page.</p> <p>Detailed design will go to April Council and construction will begin Mid May.</p>

	Strategic Projects Reserve to fund contingency and project management costs for Stage 1 of the project.				
C.04/0223 Greys Hill Road 50km/h Speed Zone	That a request be submitted to Main Roads Western Australia seeking an extension of the 50km/h speed limit that currently ends on Grey's Hill Road to a point past its intersection with Mattamattup Street	S Alexander	<b>March 2023</b> Current traffic data required for application. Counter to be installed asap.	<b>April 2023</b> No update since last month's report	
C.05/0223 Desktop Review of Strategic Community Plan	That Council: 1. Endorse the draft briefing paper (Attachment 3) to be released during the community consultation period for the desktop review of the Strategic Community Plan  2. Authorise the CEO to make formatting changes to the draft briefing paper to improve appearance and legibility  3. Set a 6 week community consultation period for the desktop review, commencing Wednesday 1 March 2023 and concluding Wednesday 12 April 2023.	T Clynh	<b>March 2023</b> Currently out for consultation.	<b>April 2023</b> Consultation has been completed with an update to be provided shortly.	
C.13/0223 Development Compliance Policy	That Council: 1. Adopt, for the purposes of public advertising, the draft Local Planning Policy titled 'Development Compliance Policy' attached to this agenda as Attachment 14 in accordance with Regulation 4 of Schedule 2 of the Planning and Development (Local Planning Schemes) Regulations 2015  2. Advertise the draft policy in accordance with the requirements of regulations 4 and 87 of the Planning and Development (Local Planning Schemes) Regulations 2015 for a period of 28 days by undertaking the following actions: i. Advertise a notice regarding the draft policy on the Shire's website for the whole duration of the public advertising period, and in a local newspaper once during the first week of the public advertising period	P St John	<b>March 2023</b> Draft Policy adopted in February 2023. Public consultation will now occur and final consideration of the Policy and any public comments is expected in April / May 2023. Public notice of the draft policy occurred 22 March 2023 in accordance with legislation and council resolution.	<b>April 2023</b> Advertising of the draft Policy concluded on 19 April. The draft will be included on the Council agenda for May, including addressing the specific issues discussed at Concept Forum on 13 April.	

	<ul style="list-style-type: none"> <li>ii. Making the draft policy available for viewing on the Shire's website for the whole duration of the public advertising period with the ability for the document to be downloaded and printed if a person wishes to do this</li> <li>iii. Providing hard copies of the draft policy for public inspection at the Shire Administration Building for the whole duration of the public advertising period</li> </ul> <p>3. Give further consideration to the draft Policy following closure of public advertising and consideration of any public submissions.</p>				
SpC.02/0323 Draft Local Planning Scheme No. 6	<p>That Council:</p> <ul style="list-style-type: none"> <li>1. In accordance with section 72 of the Planning and Development Act 2005 and regulation 21 of the Planning and Development (Local Planning Schemes) Regulations 2015, adopt, for the purposes of public advertising, the draft Shire of Bridgetown-Greenbushes Local Planning Scheme No. 6 consisting of the Scheme text and Scheme maps as shown in Attachments 1 and 2</li> <li>2. Forward copies of the draft Scheme documents to: <ul style="list-style-type: none"> <li>i. The Environmental Protection Authority for consideration pursuant to section 81 of the Planning and Development Act 2005.</li> <li>ii. The Western Australian Planning Commission for consideration and advice to the local government, pursuant to regulation 21 of the Planning and Development (Local Planning Schemes) Regulations 2015</li> </ul> </li> <li>3. Subject to receipt of advice from the Environmental Protection Authority and the Western Australian Planning Commission, advertise the draft Scheme in accordance with the requirements of regulations 22 and 76A of the Planning and Development (Local Planning Schemes) Regulations 2015 for a period of 90 days by undertaking the following</li> </ul>	P St John	<p><b>March 2023</b></p> <p>Draft Scheme adopted in March 2023 Special Council meeting. Scheme documents have now been submitted to DPLH and DWER.</p>	<p><b>April 2023</b></p> <p>A response has been received from DWER on the draft Scheme. This response is seeking considerable additional information. Officers are preparing a response to DWER on this issue and will be meeting with DWER / DPLH in the near future to progress this and attempt to minimum any delay in progress of the Scheme review.</p>	



	<p>actions:</p> <ul style="list-style-type: none"> <li>i. Advertise a notice regarding the draft scheme, prepared under the provisions of regulation 22(1), on the Shire's website for the whole duration of the public advertising period, and in a local newspaper under the provisions of regulation 76A(4) for three consecutive weeks commencing in the first week of the public advertising period.</li> <li>ii. Making the scheme documents (scheme text and maps) available for viewing on the Shire's website for the whole duration of the public advertising period in accordance with regulations 22(2) and 76A(3), with the ability for the documents to be downloaded and printed if a person wishes to do this.</li> <li>iii. Providing hard copies of the scheme text and maps for public inspection at the Shire Administration office for the whole duration of the public advertising period in accordance with regulation 76A(3)(b).</li> <li>iv. Provide a plain language overview of the planning scheme review and preparation process and a list of Frequently Asked Questions (FAQ's) on the Shire's website and make the overview and FAQ's available as a printed information pack which is available at the Administration Building or sent to residents/property owners on request.</li> <li>v. Provide a dedicated email address to which questions on the draft scheme may be submitted during the first 60 days of the advertising period, with a commitment that a written response will be provided within 21 days of receipt and, if the question is likely to be of general interest and does not disclose information about a</li> </ul>				
--	---	--	--	--	--

	<p>specific person or property, the question and response (or a redacted version) will be added to the FAQ's on the Shire website</p> <p>4. After the end of the public advertising period, a further report be presented for Council's consideration providing details of all submissions received and recommended responses to address issues raised in submissions, in accordance with Regulation 25 of the Planning and Development (Local Planning Schemes) Regulations 2015.</p>				
SpC.03/0323 Proposed Budget Amendment – Reallocation of Portion Local Roads and Community Infrastructure Program Phase 3	<p>That Council:</p> <ol style="list-style-type: none"> <li>1. Seek the approval of the Australian Government for a change of project for Local Roads and Community Infrastructure Program Phase 3. This would replace the Nelson Street Footpath Resurfacing Project (\$80,000) with the following project: <ul style="list-style-type: none"> <li>• Blechynden Street Asphalt Overlay – overlay the section from RoeStreet to Barlee Street, replacement kerbing and reinstatement of the short footpath next to the school drop-off bay.</li> </ul> </li> <li>2. Amend its 2022/23 Budget as follows: <ol style="list-style-type: none"> <li>a. Decrease budget allocation for Job FP05 – 'Nelson Street Footpath' by \$80,000 (from \$80,000 to \$0)</li> <li>b. Include new budget allocation of \$80,000 to new "RC" Job No. 'Blechynden Street'.</li> </ol> </li> </ol>	T Clynych	<b>March</b> Application for variation has been submitted.	<b>April 2023</b> No update.	
C.03/0323 South Western Highway and Stanifer Street Intersection	That a request be submitted to Main Roads Western Australia seeking it investigate the installation of lighting at the intersection of South Western Highway and Stanifer Street, Greenbushes.	S Alexander		<b>April 2023</b> Request has been made. Awaiting a response.	
C.05/0323 Establishment of a new 'Sustainability	1. That in its 2023/24 budget Council establish a 'Sustainability Reserve' with the purpose of the reserve to be: "to provide environmental benefits to Council and	M Larkworthy		<b>April 2023</b> No progress.	

Reserve' in 2023/24 Budget	<p>the community, combat rising costs of energy and reduce the carbon footprint of corporate operations with energy-efficiency initiatives, implement water-wise and waste-reduction initiatives, and create future cost savings to be reinvested into the delivery of new sustainability projects”.</p> <p>4.That the \$10,000 contained in Council's 2022/23 budget for development of a local climate change plan/strategy be quarantined for initial funding of the Sustainability Reserve and Council consider possible additional funding of the reserve in the 2023/24 budget process.</p>				
C.05/0323 Establishment of a new 'Sustainability Reserve' in 2023/24 Budget	<p>5.That the CEO present a draft 'Sustainability Reserve' policy to Council by its June 2023 meeting with the contents of the draft policy providing guidance on how the reserve will be funded in future, for example how to estimate “sustainability savings” for transfer into the reserve and how a specific timeframe for reinvestment could be included for the funds to act as a revolving sustainability fund.</p>	T Clynch		<b>April 2023</b> No progress.	
C.08/0323 Greenbushes Bus Bays	<p>That Council:</p> <p>2. Seek the approval of the Public Transport Authority to remove the current bus stop on the northern side of Stanifer Street and that the indented bus bay on the southern side of Stanifer Street be the sole bus stop in Greenbushes for buses travelling north and south.</p>	T Clynch		<b>April 2023</b> No progress.	
C.16/0323 Resignations of Cr Amanda Rose and Cr Peter Quinby	<p>That Council:</p> <p>3.Seek the approval of the Electoral Commissioner to allow the two vacancies to remain unfilled until the 2023 Local Government Ordinary Election, in accordance with section 4.17(3) of the Local Government Act 1995.</p>	T Clynch		<b>April 2023</b> Request to allow the vacancies to remain unfilled sent to the WAEC Commissioner, awaiting response.	



## FREEDOM OF INFORMATION ACT

### 2023 INFORMATION STATEMENT

#### Contents

Introduction.....	3
Our Vision and Values.....	3
Shire Profile.....	3
Legislative Framework.....	3
Local Laws.....	4
Shire of Bridgetown-Greenbushes Structure.....	4
Council Structure.....	4
Committees of Council.....	4
Management Structure.....	6
Directorate Areas of Responsibility.....	6
Decision making by the Shire.....	8
Policies & Delegation of Authority.....	8
Public participation in the decision making process.....	8
Council Meetings.....	8
Public Question Time.....	8
Petitions.....	9
Deputations.....	9
Comments on Agenda Items by Parties with an Interest.....	9
Annual General Meeting of Electors.....	9
Special Meetings of Electors.....	9
Community Consultation and Participation.....	10
Documents held by the Shire of Bridgetown-Greenbushes.....	10
FOI Procedures.....	11
Freedom of Information Applications.....	11
Freedom of Information Charges.....	11
Amendment of Council Records.....	12
Access Arrangements.....	12
Notice of Decision.....	12

Refusal of Access .....	13
Internal Review .....	13
External Review .....	14
Further Information .....	14
Appendix 1 – List of legislation administered by the Shire.....	15
Appendix 2 – FOI Application.....	17

## Introduction

The Western Australian *Freedom of Information Act 1992* (FOI Act) is designed to enable the public to participate more effectively in governing the State, and to make the persons and bodies that are responsible for State and local government more accountable to the public.

Under Part 5 of the FOI Act, the Shire of Bridgetown-Greenbushes is required to prepare and publish an annual Information Statement. This document has been created to comply with that requirement, and is correct as at April 2023. A copy of the Statement can be accessed via the Shire's website at [www.bridgetown.wa.gov.au/freedom-of-information-link](http://www.bridgetown.wa.gov.au/freedom-of-information-link).

## Our Vision and Values

### Our Vision

*Bridgetown Greenbushes*  
*The heart and soul of the South West*

### Our Values

We conduct ourselves in line with the values that the local community cares deeply about. We always strive to be:

- Welcoming
- Community minded
- Creative
- Sustainable
- Cost effective

## Shire Profile

Located in the heart of the Blackwood River valley, the Shire of Bridgetown-Greenbushes is able to boast beautiful scenery, stunning heritage buildings, extensive forests, national parks, wineries and heritage walk trails. The district includes the heritage town of Bridgetown, the town of Greenbushes with a long and proud mining history and other localities such as Catterick, Hester, Hester Brook, Kangaroo Gully, Kingston, Maranup Ford, North Greenbushes, Sunnyside, Wandillup, Winnejup and Yornup.

The town of Bridgetown is located approximately 268 kilometres south of Perth and 95 kilometres south of Bunbury and Greenbushes is located 17 kilometres north of Bridgetown. The district is bordered by the Shires of Boyup Brook to the north and east, Manjimup to the south, Nannup to the west and Donnybrook-Balingup to the north.

As at 30 June 2021 the Shire of Bridgetown-Greenbushes has an estimated population of 5,238 and covers 1,691 km<sup>2</sup> of agricultural farmland, State forest and national parks, mining leases, Crown land and townsites. The majority of the Shire is within the Blackwood River catchment area.

## Legislative Framework

The operations of local government in Western Australia are governed by the *Local Government Act 1995* (Act), the various Local Government Regulations, and any other legislation that provides powers and responsibilities to local governments. A non-exhaustive list of legislation administered

by the Shire is provided at Appendix 1 to this document. This list is not exhaustive or comprehensive and may not be current. Confirmation of current Acts and Regulations is recommended by referring to the Western Australian Legislation website at [www.legislation.wa.gov.au](http://www.legislation.wa.gov.au).

### **Local Laws**

Under the Act the Shire has the power to make and administer local laws in relation to matters which come under its functions as set out in the Act or other written law which expressly applies to local government. Local laws regulate and relate to activities which may be conducted within the area of the Shire.

The Shire's Local Laws include:

- Activities on Thoroughfares and Trading in Thoroughfares and Public Places
- Bush Fire Brigades
- Cats
- Cemeteries
- Dogs
- Fencing
- Health
- Local Government Property
- Parking and Parking Facilities
- Standing Orders

## **Shire of Bridgetown-Greenbushes Structure**

The Shire of Bridgetown-Greenbushes provides a wide range of services and facilities for its ratepayers, residents and visitors to the Shire. The Shire has a role in the management, improvement and development of the resources within its area so as to create a safe and pleasant environment for its community.

### **Council Structure**

The Council of the Shire of Bridgetown-Greenbushes consists of 9 elected members (Councillors). Councillors are elected from the community to serve their community in a voluntary capacity. The Council acts as a community board, establishing policies and making decisions within the rules of the Act on a wide range of issues affecting the community.

Local government elections are held every two years to fill vacancies which occur as elected members conclude their four year term of office. Following the elections, a special meeting is held whereby newly elected Councillors are sworn into office. Following this swearing-in ceremony, an election takes place to fill the positions of Shire President and Deputy President for the ensuing two year period.

### **Committees of Council**

To assist its work load and processes, Council can elect to establish Committees. The following Committees of Council have been established in accordance with Section 5.8 of the Act to assist

Council achieve its objectives. The term of office for committees established by Council is generally two years (or less) with the expiry date being tied to local government elections.

The following Committees currently assist Council in achieving its objectives:

- Access and Inclusion Advisory Committee
- Audit Committee
- Bush Fire Advisory Committee
- CEO Performance Review Committee
- Local Emergency Management Committee
- Roadwise Advisory Committee
- Sustainability Advisory Committee
- Trails Development Advisory Committee
- Youth Services Advisory Committee

In addition to Committees established under the Act, the Council appoints Working Groups from time to time to consider specific issues or projects. Generally, the membership of a Working Group consists of elected members and staff however members of the public may also be appointed if considered necessary. Working Groups have no delegated authority and provide recommendations to Council.



## Management Structure

The operations of the Shire and implementation of Council decisions are managed by the Chief Executive Officer who is supported by an Executive Management Team.

A visual overview of the management structure of the Shire is below. Executive Managers head up the Development & Infrastructure, Corporate Services and Community Services directorates.

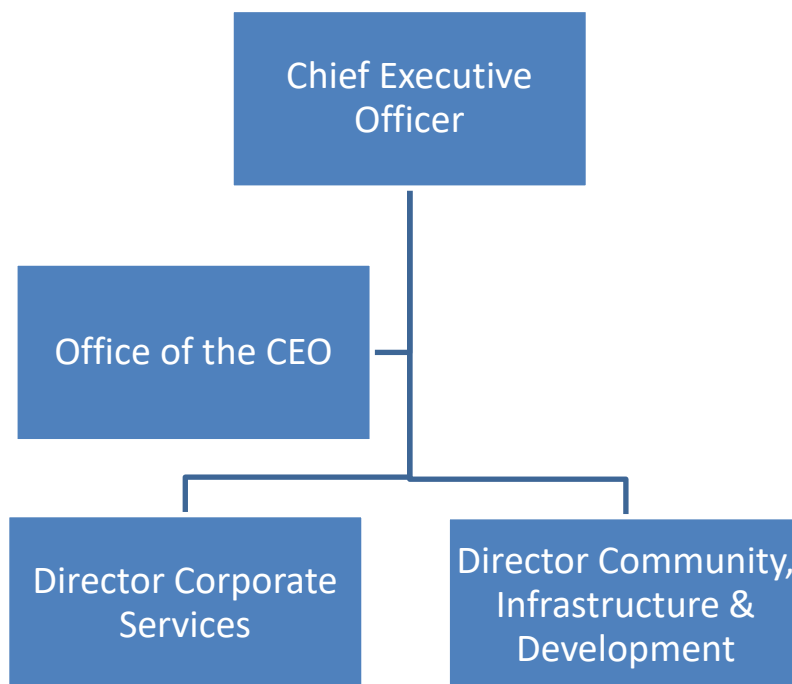

## Directorate Areas of Responsibility

The CEO is responsible for managing the day to day operations of the Shire with two Directors to assist with the following broad areas of responsibility.

Office of the CEO	
Organisational Overview & Compliance	Strategic Management
Council Meetings	Concept Forums
Shire President & Councillors Liaison	Strategic Community Plan
Workforce Plan	Citizenship
Property Disposition	Local Government Elections
Bush Fire Mitigation	Council & Operational Policy/Procedures
Organizational Communications	Human Resources
Work, Health & Safety	Change Management
Emergency Services	Ranger Services (12 months only)

Corporate Services
--------------------

<b>Financial Compliance</b>	Annual Budget
<b>Debtors/Creditors</b>	Insurance
<b>Rates</b>	Payroll
<b>Annual Financial Reports</b>	Long Term Financial Plan
<b>Asset Management</b>	Records Management
<b>Customer Service</b>	Police Licensing
<b>Information Technology (IT)</b>	Risk Management & Compliance
<b>Building Maintenance</b>	Cleaning of Shire Facilities
<b>Cemetery Bookings</b>	Management Visitor Centre
<b>Local Laws</b>	

### **Community, Infrastructure and Development**

<b>Town Planning – Development Approvals</b>	Town Planning - Subdivisions
<b>Town Planning Zoning (Local Planning Schemes &amp; Local Planning Strategy)</b>	Private and Public Swimming Pool Inspections
<b>Road Naming</b>	Heritage Assessments
<b>Building Control/Permits</b>	Public Building Approvals
<b>Environmental Health</b>	Project Management (selected projects)
<b>Road, Footpath, Drainage Construction</b>	Road, Footpath, Drainage Maintenance
<b>Traffic Control</b>	Regulatory Road Signage
<b>Street Tree Maintenance and Assessment</b>	Parks and Gardens Maintenance
<b>Weed Management</b>	Restricted Access Vehicle Approvals
<b>Cemetery Maintenance</b>	Waste Management
<b>Community Development</b>	Service Agreements & Community Grants
<b>Trails Development</b>	Arts & Culture
<b>Seniors Issues</b>	Youth issues
<b>Access and Inclusion</b>	Cultural Awareness
<b>Library</b>	Leisure Centre

## Decision making by the Shire

The Council makes decisions which direct and/or determine the activities of the organisation as administered by the CEO. In addition, the Council:

1. Determines the type, range and scope of projects to be undertaken by the Shire;
2. Develops comprehensive strategic plans, budgets, financial controls and performance objectives and indicators for the operations of the Shire; and
3. Develops and adopts policies to be applied on the Council's behalf by the CEO.

The Council makes decisions which direct and/or determine its activities and functions. Such decisions include the approval of works and services to be undertaken, and the allocation of resources to works and services.

Decisions are also made to determine whether or not approvals are to be granted for applications from residents for various forms of development.

### Policies & Delegation of Authority

Council adopts Policies on a variety of issues to act as a guide for Officers of the Shire of Bridgetown-Greenbushes. Policy Manuals have been developed and distributed to Councillors and Officers to assist in the decision making process. In addition, the CEO has delegated authority from Council to make decisions on a number of specified administrative and policy matters. These delegations are listed in a Register and (along with Policies) are reviewed on an annual basis in keeping with the legislative requirement. These are both public documents and can be viewed on the Shire's website at [www.bridgetown.wa.gov.au/documents](http://www.bridgetown.wa.gov.au/documents).

## Public participation in the decision making process

Members of the public have a number of opportunities to participate in the formulation of the Shire's plans, policies and strategies as well as comment on the performance of the Shire's functions.

### Council Meetings

The Council meets on the last Thursday in each month (excepting December) and encourages members of the public to be in attendance. A Public Question Time segment is held at the commencement of each Ordinary Meeting of Council to allow the public a forum in which they may raise questions regarding agenda items or other issues affecting the community.

Agendas for Ordinary Meetings of Council are posted on the website and are available for inspection at the Bridgetown Regional Library from the Friday in the week prior to Council meeting day.

On occasions there may be a Special Meeting of Council if a matter of particular urgency arises. Any notice of Special Meeting or changes to the time, dates or venues for scheduled Council Meetings is publicly advertised.

### Public Question Time

To assist members of the public to participate in the decision making process of the Shire, Public Question Time is available for a period of 15 minutes at the commencement of each Ordinary Meeting of Council. Members of the public with questions are asked to write down their question with their name and address, and to read their question aloud.

The question will either be responded to, taken on notice or not accepted by the Presiding Officer.

If a question is taken on notice then it will be recorded and a written response provided to the questioner by the CEO as soon as possible, and a copy of the response included in the agenda of the next meeting of the Council.

### **Petitions**

Electors may put requests to Council by way of a petition. For a petition to be effective it needs to be addressed to the President and made by registered electors of the Shire of Bridgetown-Greenbushes. The petition must state the request on each page of the petition and contain the names, addresses and signatures of each elector making the request, as well as the date on which each elector signed the request. The petition must also contain a summary of the reasons for the request and state the name of the person upon whom, and address at which, notice to the petitioners can be given.

Further details regarding the requirements for petitions can be found in the Shire of Bridgetown-Greenbushes Standing Orders Local Law which is available on our website via this link: [www.bridgetown.wa.gov.au/documents/local-laws](http://www.bridgetown.wa.gov.au/documents/local-laws).

### **Deputations**

Persons wishing to make a deputation to the Council or a committee are to apply in writing to the CEO outlining the subject matter to be raised by the deputation. On receiving such a request the CEO shall notify the President, or the presiding member if the deputation is to be made to a committee, who may elect to invite the deputation to attend.

All requests for a deputation should be marked for the attention of the Chief Executive Officer and may be:

- posted to PO Box 271, Bridgetown, WA 6255; or
- hand delivered to the reception of the Shire of Bridgetown-Greenbushes Administration Building, 1 Steere Street, Bridgetown; or
- faxed to (08) 9761 2023; or
- e-mailed to [btnshire@bridgetown.wa.gov.au](mailto:btnshire@bridgetown.wa.gov.au)

### **Comments on Agenda Items by Parties with an Interest**

At a Council or Standing Committee meeting persons with a relevant interest in an item included in the agenda of the meeting are able to address the meeting. The determination of whether a person has an interest in an agenda item is made in accordance with Clause 3.4.3 of the Shire of Bridgetown-Greenbushes Standing Orders Local Law and includes applicants, representatives of applicable organisations, adjacent property owners, authors of submissions or any person in the opinion of the presiding member at the meeting that has a significant direct interest (not including an interest common to all or a significant number of the community).

### **Annual General Meeting of Electors**

In addition to its Ordinary Meetings, Council also holds an Electors Meeting during each financial year and includes the presentation of the Annual Report and the Annual Financial Report & Auditors Report.

### **Special Meetings of Electors**

In accordance with Section 5.28 of the Act, a Special Meeting of Electors may be held following a request made to the President for such a meeting by:

- not less than one hundred electors or 5% of the number of electors, whichever is the lesser; or
- one third of the number of council members.

Any request of this nature is to specify the matters to be discussed at the Meeting and the form or content of the request is to be in accordance with the requirements of the *Local Government (Administration) Regulations 1996*.

### Community Consultation and Participation

The Council believes that early effective communication and consultation with the Community will lead to better decision-making, and more open, transparent and accountable governance. Council's Community Consultation Policy outlines both the various levels of consultation and the methods used.

Community members also have the opportunity to engage with the Shire at any time by visiting our reception at the Shire's Administration Building, 1 Steere Street, Bridgetown between the hours of 9:00am and 4:30pm, by calling (08) 9761 0800 or by emailing [btnshire@bridgetown.wa.gov.au](mailto:btnshire@bridgetown.wa.gov.au).

Community members can also provide feedback and make enquiries or complaints on-line via the Contact page of the Shire's website at [www.bridgetown.wa.gov.au/contact-us/contact.aspx](http://www.bridgetown.wa.gov.au/contact-us/contact.aspx) or by visiting and leaving a comment on the Shire's Facebook page at [www.facebook.com/bridgetowngreenbusheshire](http://www.facebook.com/bridgetowngreenbusheshire).

### Documents held by the Shire of Bridgetown-Greenbushes

In accordance with section 5.94 of the Act, certain documents are made available by the Shire for public inspection without an application under the FOI Act being necessary. Many of these documents are available on the Shire's website, and can include:

- any code of conduct;
- any register of complaints referred to in section 5.121 of the Act;
- any register of financial interests;
- any register of gifts;
- any annual report;
- any annual budget;
- any schedule of fees and charges;
- any plan for the future of the district made in accordance with section 5.56 of the Act;
- any proposed local law of which the local government has given Statewide public notice under section 3.12(3) of the Act;
- any local law made by the local government in accordance with section 3.12 of the Act;
- any rates record;
- any confirmed minutes of council or committee meetings;
- any minutes of electors' meetings;
- any notice papers and agenda relating to any council or committee meeting (excluding those

reports prepared under Section 5.23 of the Act);

- any report of a review of a local law prepared under section 3.16(3);
- any business plan prepared under section 3.59 of the Act;
- any register of owners and occupiers under section 4.32(6) of the Act and electoral rolls;

Access to other information held by the Shire is subject to the provisions of the Act, the FOI Act and any other pertinent legislation.

## FOI Procedures

It is the aim of the Shire of Bridgetown-Greenbushes to make information available promptly and at the least possible cost, and whenever possible documents will be provided outside the FOI process.

If information is not routinely available, the FOI Act provides the right to apply for documents held by the agency and to enable the public to ensure that personal information in documents is accurate, complete, up-to-date and not misleading.

### Freedom of Information Applications

Requests to access information under the FOI Act are required to:

- be in writing;
- give enough information so that the documents requested can be identified;
- give an Australian address to which notices can be sent; and
- be lodged at the agency with any application fee payable.

An application form is available to assist with this process and is attached as Appendix 2 to this document.

Applications and enquiries should be addressed to:

Freedom of Information Officer

Shire of Bridgetown-Greenbushes

PO Box 271

Bridgetown WA 6255

Or

E-mailed to [btnshire@bridgetown.wa.gov.au](mailto:btnshire@bridgetown.wa.gov.au).

Applications will be acknowledged in writing and you will be notified of the decision within 45 calendar days of the Shire's receipt of the properly completed Freedom of Information Request form or written application, together with the application fee.

### Freedom of Information Charges

A scale of fees and charges are set out in the FOI Regulations. No fees or charges apply for personal information or amendment of personal information about yourself. Applications for other documents (i.e. which are non-personal in nature) require a \$30 application fee to be paid when the application is lodged.

As at 31 March 2023 the fees and charges are as follows:

Personal Information about the applicant	No fee and no charges
Application fee (for non-personal information)	\$30.00
Charge for time dealing with the application (per hour or pro rata)	\$30.00
Access time supervised by staff (per hour or pro rata)	\$30.00
Photocopying staff time (per hour or pro rata)	\$30.00
Photocopying	\$0.20/page
Transcribing from tape, film or computer (per hour or pro rata)	\$30.00
Duplicating a tape, film or computer information	Actual cost
Delivery, packaging or postage	Actual cost

An estimate of charges will be provided if the cost is expected to exceed \$25.00. For impecunious applicants or those issued with prescribed pensioner concession cards, any charges payable are reduced by 25%.

### Deposits

- An advance deposit may be required in respect of the estimated charges – 25%
- Further advance deposit may be required to meet the charges for dealing with the applications – 75%
- If a required deposit is not paid within a timeframe specified by the Shire, then the applicant is to be regarded as having withdrawn the access application.

### Amendment of Council Records

Section 45 of the FOI Act gives an individual the right to apply for amendment of personal information about the person contained in a document of a government agency, if the information is inaccurate, incomplete, out of date or misleading.

All applications of this nature must be in writing and contain:

- details of the information to be identified;
- details of the matter that is believed to be inaccurate, incomplete, out of date or misleading; and
- reasons for the belief.

### Access Arrangements

Access to documents can be granted by way of inspection; a copy of a document; a copy of an audio or video tape; a computer disk; or a transcript of a recorded, shorthand or encoded document from which works can be reproduced.

It should be noted that some documents are for viewing only as the supply of copies by the Shire may result in a breach of the Copyright Act 1968.

### Notice of Decision

As soon as possible but in any case, within 45 days you will be provided with a notice of decision which will include details such as –

- the date the decision was made;

- the name and the designation of the officer who made the decision;
- if access is refused, the reasons for claiming the document is exempt; and
- information on the rights of review and the procedures to be followed to exercise those rights.

### Refusal of Access

While the FOI Act provides a general right of access to documents, Schedule 1 of the Freedom of Information Act recognises that some documents require a level of protection.

These Include:

- Personal information about other individuals.
- Commercially valuable information or information concerning trade secrets.
- Legal advice.
- Information that would reveal a decision made during a deliberative process closed to the public.
- Confidential communications.
- Law enforcement, Public Safety and Property Security.

However, exemptions may not be claimed unless there are good reasons to deny access to requested information.

The Shire of Bridgetown-Greenbushes is required to give full reasons for denying access to documents detailed in their Notice of Decision.

### Internal Review

If the applicant is not satisfied with this decision, you have a right to apply for an internal review by the agency.

An application for internal review must be lodged with the agency within thirty (30) days after receiving the notice of decision and must:

- be in writing;
- provide particulars of the decision to be reviewed; and
- give an address in Australia.

There is no lodgement fee for an application for internal review and there is no charge for dealing with an internal review request.

If an application for internal review is received, it will not be dealt with by the person who made the initial decision, or by any person who is subordinate to the original decision maker. The outcome for an application for internal review may result in a confirmation, variation or reversal of the initial decision under review. You will be advised of the outcome within fifteen (15) days.

The address for lodgment of an internal review is:

Chief Executive Officer

Shire of Bridgetown-Greenbushes

PO Box 271



Bridgetown WA 6255

Or

Email: [btnshire@bridgetown.wa.gov.au](mailto:btnshire@bridgetown.wa.gov.au)

### External Review

If the applicant is not satisfied with this decision, they have the right to lodge a complaint with the Information Commissioner, seeking an external review of that decision. The applicant is required to lodge their complaint with the Information Commissioner's office within sixty (60) calendar days of receiving written notice of the Shire's decision.

Note: if the applicant is requesting an external review as a third party, or following an application for amendment of personal information, they must lodge their external review application within thirty (30) calendar days after being given written notice of the Shire's decision.

A complaint to the Information Commissioner must:

- be in writing;
- have attached to it a copy of this decision; and
- give an address in Australia

There is no charge for lodging a complaint with the Information Commissioner's office.

Contact details of the Information Commissioner are:

Office of the Information Commissioner

Albert Facey House

469 Wellington Street

Perth WA 6000

Telephone: (08) 6551 7888

1800 621 244 (toll free for WA country callers)

Email: [info@foi.wa.gov.au](mailto:info@foi.wa.gov.au)

Website: <http://www.oic.wa.gov.au>

### Further Information

Further information can be obtained from the Freedom of Information Officer for the Shire on (08) 9761 0800, Monday to Friday from 8.30am to 5.00pm or in writing to:

Freedom of Information Officer

Shire of Bridgetown-Greenbushes

PO Box 271

Bridgetown WA 6255

Email: [btnshire@bridgetown.wa.gov.au](mailto:btnshire@bridgetown.wa.gov.au)

Alternatively, contact the Office of the Information Commissioner (refer above for contact details).

## Appendix 1 – List of legislation administered by the Shire

This list of Acts is not intended to be exhaustive and should not be relied upon as such. Confirmation of current Acts and the associated Regulations by referring to Western Australian Legislation website at [www.legislation.wa.gov.au](http://www.legislation.wa.gov.au)

Animal Welfare Act 2002

Building Act 2011

Building and Construction Industry Training Fund Levy Collection Act 1990

Bush Fires Act 1954

Caravan Parks & Camping Grounds Act 1995

Cat Act 2011

Cemeteries Act 1986

Control of Vehicles (Off-Road Areas) 1978

Dividing Fences Act 1961

Dog Act 1976

Emergency Services Levy Act 2002

Environmental Protection Act 1986

Food Act 2008

Freedom of Information Act 1992

Health Act 1911

Heritage Act 2018

Land Administration Act 1997

Liquor Control Act 1988

Litter Act 1979

Local Government Act 1995

Local Government (Miscellaneous Provisions) Act 1960

Work Health and Safety Act 2020

Planning and Development Act 2005

Plumbers Licensing Act 1995

Public Health Act 2016

Public Works Act 1902

Rates and Charges (Rebates and Deferments) Act 1992

Road Traffic Act 1974

Strata Titles Act 1985

Tobacco Products Control Act 2006

Transfer of Land Act 1893

Valuation of Land Act 1978

Waste Avoidance and Resource Recovery Act 2007

Water Services Licensing Act 1995

**Other Legislation Affecting the Shire**

Activities in Thoroughfares and Trading in Thoroughfares and Public Places Local Law

Bush Fire Brigades Local Law

Cats Local Law

Cemeteries Local Law

Dogs Local Law

Fencing Local Law

Health Local Law

Local Government Property Local Law

Parking and Parking Facilities Local Law

Standing Orders Local Law

Town Planning Scheme No. 3

Town Planning Scheme No. 4

# Appendix 2 – FOI Application

SHIRE OF BRIDGETOWN-GREENBUSHES

## APPLICATION FOR ACCESS TO DOCUMENTS

[Freedom of Information Act 1992, S.12]

### DETAILS OF APPLICANT

Family Name: ..... Given Names: .....

Australian Postal Address: .....

Postcode: ..... Telephone No: .....

### If application is on behalf of an Organisation

Name of Organisation/Business: .....

DETAILS OF REQUEST (Please tick)  Personal documents  Non-Personal documents

I am applying for access to document(s) concerning: .....

.....

### FORM OF ACCESS (Please tick)

I wish to inspect the document(s)  Yes  No

I require a copy of the document(s)  Yes  No

I require access in another form  Yes  No

If Yes, please specify:

.....

### FEES & CHARGES

Attached is a cheque/cash for the amount of \$..... to cover the application fee. I understand that before I obtain access to documents I may be required to pay processing charges in respect of this application and that I will be supplied with a statement of charges if appropriate.

*In certain cases a reduction in fees and charges may apply – see section on fees and charges on the back of this form. If you consider you are entitled to a reduction, submit a request with copies of documents which address the criteria on the back of this form and support your application for a fee reduction.*

I am requesting a reduction in fees and charges  Yes  No

Applicants Signature:	Date:
-----------------------	-------

### Office Use Only

Date Received: .....

Deadline for Response: .....

Acknowledgement sent: .....

## NOTES

### FOI Applications

- Please provide sufficient information to enable the correct document(s) to be identified
- The Agency may request proof of your identity
- If you are seeking access to a document(s) on behalf of another person, the Agency will require authorisation, usually in writing
- Your application will be dealt with as soon as practicable (and, in any case, within 45 days) after it is received
- Further information can be obtained from the Shire of Bridgetown-Greenbushes, or a copy of the Freedom of Information Act may be downloaded from the Western Australian Legislation website [www.legislation.wa.gov.au](http://www.legislation.wa.gov.au). Alternatively hardcopies can be ordered from the State Law Publisher by emailing [sales@dpc.wa.gov.au](mailto:sales@dpc.wa.gov.au) or calling 08 6552 6000.

### Forms of Access

You can request access to documents by way of inspection, a copy of a document, a copy of an audio or video tape, a computer disc, a transcript of a recorded document or of words recorded in shorthand or encoded form, or a written document in the case of a document from which words can be reproduced in written form.

Where the Agency is unable to grant access in the form requested, access may be given in a different format.

### Fees & Charges

- \$30.00 application fee (non-personal information only) and other fees as outlined in Schedule 1 of the FOI Regulations
- An applicant who is the holder of a currently valid concession card issued on behalf of the Commonwealth Government under the Rates & Charges (Rebates and Deferments) Act 1992 may be eligible for a reduction of 25% in the charges associated with the application.
- No reduction is applicable to the application fee.

### Lodgement of Applications

Applications may be lodged:

- By post addressed to: Freedom Of Information Officer  
Shire of Bridgetown-Greenbushes  
PO Box 271  
BRIDGETOWN WA 6255
- In person at: Shire of Bridgetown-Greenbushes Administration Office  
1 Steere Street  
BRIDGETOWN WA 6255
- E-mailed to: [btnshire@bridgetown.wa.gov.au](mailto:btnshire@bridgetown.wa.gov.au)

**SHIRE OF BRIDGETOWN-GREENBUSHES**  
**LIST OF ACCOUNTS PAID IN MARCH TO BE RECEIVED**

<b>Cheque/ Voucher No.</b>	<b>Date of Payment</b>	<b>Payee</b>	<b>Payment Description</b>	<b>Payment Amount \$</b>
<b><u>MUNICIPAL FUND</u></b>				
<b>DIRECT DEBITS</b>				
DD16607.1	08/03/2023	AWARE SUPER	PAYROLL DEDUCTIONS	14,571.41
DD16607.2	08/03/2023	COLONIAL FIRST STATE SUPER	PAYROLL DEDUCTIONS	647.83
DD16607.3	08/03/2023	CARE SUPER	PAYROLL DEDUCTIONS	370.69
DD16607.4	08/03/2023	NETWEALTH SUPERANNUATION	SUPERANNUATION CONTRIBUTIONS	338.68
DD16607.5	08/03/2023	MLC MASTERKEY SUPER	SUPERANNUATION CONTRIBUTIONS	74.46
DD16607.6	08/03/2023	WAIKAWA DREAMING SUPER FUND	PAYROLL DEDUCTIONS	744.62
DD16607.7	08/03/2023	COLONIAL FIRST STATE SUPER	PAYROLL DEDUCTIONS	452.58
DD16607.8	08/03/2023	TRUBUD SUPERANNUATION FUND	SUPERANNUATION CONTRIBUTIONS	269.84
DD16607.9	08/03/2023	PLUM SUPER	SUPERANNUATION CONTRIBUTIONS	256.85
DD16607.10	08/03/2023	AUSTRALIAN ETHICAL RETAIL SUPER	SUPERANNUATION CONTRIBUTIONS	201.09
DD16607.11	08/03/2023	GUILD SUPER	PAYROLL DEDUCTIONS	536.39
DD16607.12	08/03/2023	AMP SUPER FUND	SUPERANNUATION CONTRIBUTIONS	426.47
DD16607.13	08/03/2023	UNISUPER	SUPERANNUATION CONTRIBUTIONS	944.70
DD16607.14	08/03/2023	AUSTRALIAN SUPER	SUPERANNUATION CONTRIBUTIONS	3,560.59
DD16607.15	08/03/2023	REST INDUSTRY SUPER	SUPERANNUATION CONTRIBUTIONS	691.95
DD16607.16	08/03/2023	HESTA SUPER	SUPERANNUATION CONTRIBUTIONS	197.03
DD16607.17	08/03/2023	ANZ CHOICE SUPERANNUATION	SUPERANNUATION CONTRIBUTIONS	310.77
DD16607.18	08/03/2023	HOST PLUS SUPERANNUATION FUND	SUPERANNUATION CONTRIBUTIONS	332.47
DD16616.1	15/03/2023	SG FLEET AUSTRALIA PTY LTD	MONTHLY LEASE FOR SHARED ENVIRONMENTAL HEALTH OFFICERS VEHICLE	484.22
DD16616.2	02/03/2023	GO GO MEDIA	MONTHLY ON-HOLD MESSAGE SERVICE FOR MARCH	75.90
DD16616.3	07/03/2023	AMPOL AUSTRALIA PETROLEUM PTY LTD	FUEL FOR THE MONTH OF FEBRUARY	7,750.45
DD16631.1	22/03/2023	AWARE SUPER	PAYROLL DEDUCTIONS	13,976.16
DD16631.2	22/03/2023	COLONIAL FIRST STATE SUPER	PAYROLL DEDUCTIONS	647.83
DD16631.3	22/03/2023	CARE SUPER	PAYROLL DEDUCTIONS	370.69
DD16631.4	22/03/2023	NETWEALTH SUPERANNUATION	SUPERANNUATION CONTRIBUTIONS	254.01
DD16631.5	22/03/2023	MLC MASTERKEY SUPER	SUPERANNUATION CONTRIBUTIONS	80.67
DD16631.6	22/03/2023	WAIKAWA DREAMING SUPER FUND	PAYROLL DEDUCTIONS	744.62
DD16631.7	22/03/2023	COLONIAL FIRST STATE SUPER	PAYROLL DEDUCTIONS	452.58

**SHIRE OF BRIDGETOWN-GREENBUSHES**  
**LIST OF ACCOUNTS PAID IN MARCH TO BE RECEIVED**

<b>Cheque/ Voucher No.</b>	<b>Date of Payment</b>	<b>Payee</b>	<b>Payment Description</b>	<b>Payment Amount \$</b>
DD16631.8	22/03/2023	TRUBUD SUPERANNUATION FUND	SUPERANNUATION CONTRIBUTIONS	219.34
DD16631.9	22/03/2023	PLUM SUPER	SUPERANNUATION CONTRIBUTIONS	256.85
DD16631.10	22/03/2023	AUSTRALIAN ETHICAL RETAIL SUPER	SUPERANNUATION CONTRIBUTIONS	256.85
DD16631.11	22/03/2023	TWU SUPER	SUPERANNUATION CONTRIBUTIONS	323.08
DD16631.12	22/03/2023	REST INDUSTRY SUPER	PAYROLL DEDUCTIONS	758.39
DD16631.13	22/03/2023	GUILD SUPER	SUPERANNUATION CONTRIBUTIONS	519.45
DD16631.14	22/03/2023	AMP SUPER FUND	SUPERANNUATION CONTRIBUTIONS	494.70
DD16631.15	22/03/2023	UNISUPER	SUPERANNUATION CONTRIBUTIONS	986.24
DD16631.16	22/03/2023	AUSTRALIAN SUPER	SUPERANNUATION CONTRIBUTIONS	3,280.94
DD16631.17	22/03/2023	HESTA SUPER	SUPERANNUATION CONTRIBUTIONS	197.03
DD16631.18	22/03/2023	ANZ CHOICE SUPERANNUATION	SUPERANNUATION CONTRIBUTIONS	300.07
DD16631.19	22/03/2023	HOST PLUS SUPERANNUATION FUND	SUPERANNUATION CONTRIBUTIONS	344.72
B/S	01/02/2023	WESTPAC BANK	MERCHANT FEES	1,061.93
B/S	01/02/2023	WESTPAC BANK	MONTHLY BANK ACCOUNT FEES	485.39
B/S	08/02/2023	WESTPAC BANK	TOTAL WAGES FOR 23.02.2023 - 08.03.2023	143,887.40
B/S	22/02/2023	WESTPAC BANK	TOTAL WAGES FOR 09.03.2023 - 22.03.2023	156,551.93
B/S	20/02/2023	WESTPAC CORPORATE CREDIT CARD CEO	4 X ANNUAL LICENSES FOR DROPBOX	1,142.06
B/S	20/02/2023	WESTPAC CORPORATE CREDIT CARD CEO	3 X NATIONAL POLICE CLEARANCE TOKENS	122.10
B/S	02/03/2023	WESTPAC CORPORATE CREDIT CARD CEO	MONTHLY CARD FEE	10.00
B/S	02/03/2023	WESTPAC CORPORATE CREDIT CARD DCS	MONTHLY CARD FEE	10.00
<b>BPAY</b>				
07032023	07/03/2023	TELSTRA	TELEPHONE & INTERNET CHARGES	1,184.93
17032023	17/03/2023	TELSTRA	TELEPHONE & INTERNET CHARGES	2,453.64
31032023	31/03/2023	TELSTRA	TELEPHONE & INTERNET CHARGES	1,180.48
<b>ELECTRONIC PAYMENTS</b>				
EFT36415	03/03/2023	ADAM JENKINS TREE SERVICES	INSTALLATION OF FESTIVE BANNERS AT TOWN ENTRANCE	330.00
EFT36416	03/03/2023	AFGRI EQUIPMENT AUSTRALIA PTY LTD	SUPPLY OF NEW 2022 JOHN DEERE MOTOR GRADER, LESS TRADE IN	354,750.00
EFT36417	03/03/2023	AJ & DS PAINTING	PREP & PAINT BRIDGETOWN TROTTING CLUB STEWARDS ROOM	1,892.00
EFT36418	03/03/2023	B & B STREET SWEEPING PTY LTD	MONTHLY DRAINAGE MAINTENANCE - FEBRUARY	1,914.00
EFT36419	03/03/2023	BLACKWOOD RURAL SERVICES	2 X LEAF BLOWERS FOR DEPOT	598.00

**SHIRE OF BRIDGETOWN-GREENBUSHES**  
**LIST OF ACCOUNTS PAID IN MARCH TO BE RECEIVED**

<b>Cheque/ Voucher No.</b>	<b>Date of Payment</b>	<b>Payee</b>	<b>Payment Description</b>	<b>Payment Amount \$</b>
EFT36420	03/03/2023	BRC BUILDING SOLUTIONS PTY LTD	BRIDGETOWN RAILWAY STATION CONSERVATION AND RENEWAL PROJECT	36,795.55
EFT36421	03/03/2023	BRIDGETOWN MEDICAL CENTRE	2 X PRE-EMPLOYMENT MEDICAL ASSESSMENTS	270.00
EFT36422	03/03/2023	BRIDGETOWN GLASS SERVICE	REGLAZE TOILET WINDOW AT MEMORIAL PARK PUBLIC TOILETS	297.00
EFT36423	03/03/2023	BRIDGETOWN MITRE 10 & RETRAVISION	7 PIN TRAILER ADAPTOR, CUTTING DISKS, & VARIOUS MINOR ITEMS	188.97
EFT36424	03/03/2023	BRIDGETOWN PAINT SALES	16 X CANS OF WHITE SURVEY PAINT FOR WINNEJUP RD	208.00
EFT36425	03/03/2023	BRIDGETOWN VIETNAMESE CAFE	CATERING FOR JANUARY ORDINARY COUNCIL MEETING	294.00
EFT36426	03/03/2023	BRIDGETOWN TYRES	4 X NEW TYRES, 20L COOLANT, STARTER BATTERY & PUNCTURE REPAIRS	1,566.50
EFT36427	03/03/2023	BUNBURY SETTLEMENT SERVICES	SETTLEMENT SERVICES FOR LAND EXCHANGE	2,758.94
EFT36428	03/03/2023	CAMPBELLS CANNING VALE	VARIOUS CONFECTIONARY & SNACKS FOR RESALE AT THE BLC CAFE	633.39
EFT36429	03/03/2023		CANCELLED	
EFT36430	03/03/2023	CDMI GROUP PTY LTD	SUPPLY & INSTALL ALARM SYSTEM AT OLD GAOL	1,452.00
EFT36431	03/03/2023	MIKKEL SKOU CHRISTENSEN	REIMBURSEMENT OF REFRESHMENTS FOR CUPPA WITH A COUNCILLOR	22.00
EFT36432	03/03/2023	CLOVERS GENERAL STORE	SNACK PACKS FOR EMERGENCY SERVICES INCIDENTS	1,361.25
EFT36433	03/03/2023	DAVMECH	DIAGNOSE AND REPAIR FAULTS TO VOLVO GRADER	2,200.00
EFT36434	03/03/2023	DOMESTIC MAINTENANCE SW	SUPPLY & INSTALL NEW EXTERNAL DOOR TO SOMME PARK PUBLIC TOILETS	600.00
EFT36435	03/03/2023	DRAGLINES DAM-IT CONTRACTING	HIRE OF EXCAVATOR & OPERATOR FOR CLEARING AT WINNEJUP RD	6,737.50
EFT36436	03/03/2023	LGRCEU	PAYROLL DEDUCTIONS	132.00
EFT36437	03/03/2023	FISHERS TYRE CENTRE	4 X NEW TYRES AND WHEEL ALIGNMENT FOR SUBARU LIBERTY	950.00
EFT36438	03/03/2023	FACET	REGISTRATION TO HERITAGE TOURISM WORKSHOP	119.00
EFT36439	03/03/2023	FRESHWATER IRRIGATION	DIG TRENCH FOR CHLORINE GAS DETECTORS & SERVICE OF DAM PUMP	858.00
EFT36440	03/03/2023	G.C. SALES (W.A.)	50 X 140L RED BINS, 25 X 240L RED BINS & 30 X 240L YELLOW BINS	5,436.75
EFT36441	03/03/2023	HARMONIC ENTERPRISES PTY LTD	MONTHLY MANAGED SERVICES & ANNUAL FORTIGATE THREAT PROTECTION	3,391.30
EFT36442	03/03/2023	H C JONES & CO	WATER TANK PUMP REPAIRS, REPAIR LEAKING TAP & OTHER MINOR REPAIRS	1,500.60
EFT36443	03/03/2023	HILLVIEW ELECTRICAL SERVICE	REPLACE 4 X FLURO FITTINGS FOR LED FITTINGS AT VISITOR CENTRE	616.00
EFT36444	03/03/2023	BRYANT ELBERT & KIM LESLEY HUBBARD	RATES REFUND	500.00
EFT36445	03/03/2023	IEQUIP	MACHINE HIRE FOR BUSHFIRE MITIGATION	2,434.87
EFT36446	03/03/2023	INTERFIRE AGENCIES PTY LTD	14 X PAIRS OLIVER FIREBOOTS & ZIP SETS FOR BFB PPE & HOSE WASHERS	4,167.33
EFT36447	03/03/2023	IPEC PTY LTD	FREIGHT CHARGES	113.97
EFT36448	03/03/2023	JTAGZ	200 X ORANGE LIFETIME ANIMAL REGISTRATION TAGS	104.50
EFT36449	03/03/2023	LANDGATE	LAND VALUATION ENQUIRY CHARGES	240.41



**SHIRE OF BRIDGETOWN-GREENBUSHES**  
**LIST OF ACCOUNTS PAID IN MARCH TO BE RECEIVED**

<b>Cheque/ Voucher No.</b>	<b>Date of Payment</b>	<b>Payee</b>	<b>Payment Description</b>	<b>Payment Amount \$</b>
EFT36450	03/03/2023	TRACY LANSDELL	COUNCILLOR TRAVEL CLAIM	494.42
EFT36451	03/03/2023	LOCAL GOV PROFESSIONALS WA	2 X REGISTRATION TO FINANCE PROFESSIONALS CONFERENCE	2,790.00
EFT36452	03/03/2023	MANJIMUP MONOGRAMS	EMBROIDERY OF 3 X RANGER SHIRTS	49.50
EFT36453	03/03/2023	MARKETFORCE	VARIOUS SHIRE ADVERTISEMENTS	546.29
EFT36454	03/03/2023	MIRACLE RECREATION EQUIPMENT	PLAYGROUND EQUIPMENT & FITTINGS FOR MEMORIAL PARK	2,920.50
EFT36455	03/03/2023	MOORE AUSTRALIA	2 X REGISTRATIONS TO ANNUAL BUDGET WORKSHOP	1,848.00
EFT36456	03/03/2023	MUIRS MANJIMUP	170,000 KM SERVICE FOR NISSAN XTRAIL	533.89
EFT36457	03/03/2023	NJ MECHANICAL	REPAIR HOSE ON SUNNYSIDE LIGHT TANKER	120.00
EFT36458	03/03/2023	OFFICEWORKS LTD	WIRELESS KEYBOARD & MOUSE FOR BLC	94.93
EFT36459	03/03/2023	QUALITY SHOP	FRAMING OF 4 X 2023 CITIZEN OF THE YEAR AWARDS FOR AUSTRALIA DAY	360.00
EFT36460	03/03/2023	ROOF ACCESS WA	ALTERATION & ANNUAL COMPLIANCE OF ROOF ACCESS AT LIBRARY & BLC	2,145.00
EFT36461	03/03/2023	SAFETY SOLUTIONS WA	FACILITATE WHS WORKSHOP & UPDATE PROCEDURES, FORMS & REGISTERS	3,564.00
EFT36462	03/03/2023	SCAVENGER SUPPLIES PTY LTD	MONTHLY FIRE INDICATOR SERVICE AT BLC - JANUARY	126.50
EFT36463	03/03/2023	SCHWEPES AUSTRALIA PTY LTD	DRINKS FOR RESALE AT THE BLC CAFE	747.35
EFT36464	03/03/2023	SCOPE BUSINESS IMAGING	TRAVEL CHARGES FOR MACHINE SERVICING	92.40
EFT36465	03/03/2023	SCULLY'S SMASH REPAIRS	INSURANCE POLICY EXCESS FOR NISSAN XTRAIL	300.00
EFT36466	03/03/2023	SHIRE STAFF CLUB	STAFF SOCIAL CLUB DEDUCTIONS FOR FEBRUARY	176.00
EFT36467	03/03/2023	SIGMA POOL & SPA SUPPLIES	CHEMICAL SUPPLIES FOR SWIMMING POOL	705.98
EFT36468	03/03/2023	SKATE SCULPTURE	GREENBUSHES YOUTH PRECINCT CONCEPT DESIGN, GEOTECH & PRESENTATION	10,654.70
EFT36469	03/03/2023	SPECIALTY TIMBER FLOORING WA	SANDING, RESURFACING & ALTERATIONS OF 3 X COURTS AT BLC	9,600.80
EFT36470	03/03/2023	STEWART & HEATON CLOTHING CO	7 X NAME BADGES FOR DFES PPE	34.96
EFT36471	03/03/2023	ST JOHN AMBULANCE AUSTRALIA WA	1 X FIRST AID COURSE ATTENDANCE	160.00
EFT36472	03/03/2023	SUPACHOOK CARVERY	30 X MEALS FOR FIREFIGHTERS	212.00
EFT36473	03/03/2023	SYNERGY	ELECTRICITY CHARGES	11,275.95
EFT36474	03/03/2023	TPG NETWORK PTY LTD	MONTHLY INTERNET CHARGES FOR DEPOT & LIBRARY - FEBRUARY	290.40
EFT36475	03/03/2023	T-QUIP	2 X DECK BELTS FOR TORO ZERO TURN MOWER	436.15
EFT36476	03/03/2023	TRAFFIC FORCE	TRAFFIC CONTROL FOR WINNEJUP ROAD RECONSTRUCTION WORKS	11,979.89
EFT36477	03/03/2023	TUTT BRYANT EQUIPMENT	REPLACEMENT LOCKABLE FUEL CAP FOR BOMAG LANDFILL COMPACTOR	146.77
EFT36478	03/03/2023	WAYNES METAL FABRICATION	REATTACH STAINLESS STEEL HAND RAIL AT BLC LEARN TO SWIM POOL	330.00
EFT36479	03/03/2023	SIDNEY WHITING	PA EQUIPMENT SETUP FOR AUSTRALIA DAY BREAKFAST	300.00

**SHIRE OF BRIDGETOWN-GREENBUSHES**  
**LIST OF ACCOUNTS PAID IN MARCH TO BE RECEIVED**

<b>Cheque/ Voucher No.</b>	<b>Date of Payment</b>	<b>Payee</b>	<b>Payment Description</b>	<b>Payment Amount \$</b>
EFT36480	03/03/2023	WINC AUSTRALIA PTY LTD	BULK CLEANING SUPPLIES & VARIOUS OFFICE STATIONERY	147.21
EFT36488	16/03/2023	ABCO PRODUCTS PTY LTD	BULK CLEANING SUPPLIES	731.21
EFT36489	16/03/2023	AJ & DS PAINTING	PREP & PAINT BRIDGETOWN TROTTERING CLUB BAR	3,307.70
EFT36490	16/03/2023	AMD AUDIT AND ASSURANCE	AUDIT SERVICES FOR GRANT ACQUITTAL	2,145.00
EFT36491	16/03/2023	AMITY SIGNS	VARIOUS STREET SIGNS	853.71
EFT36492	16/03/2023	ARROW BRONZE	MEMORIAL PLAQUE	572.31
EFT36493	16/03/2023	AUSTRALIA POST	ANNUAL PO BOX RENTALS & POSTAGE FOR THE MONTH OF FEBRUARY	1,048.50
EFT36494	16/03/2023	BELIA ENGINEERING	TRANSPORT OF E-WASTE FOR RECYCLING IN PERTH	825.00
EFT36495	16/03/2023	BETTER TELCO SOLUTIONS PTY LTD	MONTHLY PHONE ACCOUNT FOR FIRE CONTROL CENTRE & DEPOT - FEBRUARY	667.14
EFT36496	16/03/2023	BLACKWOOD COUNTRY GARDENS INC.	2022/23 SERVICE AGREEMENT	2,500.00
EFT36497	16/03/2023	BLACKWOOD ENVIRONMENT SOCIETY	COMMUNITY LANDCARE SERVICE 01/07/22 - 31/12/22	25,029.00
EFT36498	16/03/2023	BLACKWOODS	1 X MOROKA SNAKEBUSTER GAITERS FOR SNAKE PROTECTION	196.80
EFT36499	16/03/2023	BLACKWOOD FRESH	REFRESHMENTS FOR COUNCIL MEETING	115.37
EFT36500	16/03/2023	BLACKWOOD VETERINARY CENTRE	EUTHANASIA AND AFTERCARE OF 2 X FERAL CATS	230.00
EFT36501	16/03/2023	BLACKWOOD PROPERTY MAINTENANCE	SCRUB & PRESSURE CLEAN PUBLIC TOILET FLOORS AT MEMORIAL PARK	225.00
EFT36502	16/03/2023	BOOEASY AUSTRALIA PTY LTD	MONTHLY BOOEASY COMMISSIONS FOR FEBRUARY	220.00
EFT36503	16/03/2023	BRIDGETOWN MEDICAL CENTRE	2 X PRE-EMPLOYMENT MEDICAL ASSESSMENTS	270.00
EFT36504	16/03/2023	BRIDGETOWN TIMBER SALES	3M POLE FOR GREENBUSHES POOL SHELTER & ADMIN FEE	36.10
EFT36505	16/03/2023	BRIDGETOWN BULLDOZING PTY LTD	CONSTRUCTION OF FIRE CONTAINMENT LINES AT YORNUP FIRE	2,700.00
EFT36506	16/03/2023	BTOWN BOARDING KENNELS & CATTERY	MONTHLY ANIMAL IMPOUND CHARGES FOR FEBRUARY	621.50
EFT36507	16/03/2023	BRIDGETOWN VOLUNTEER BFB	REIMBURSEMENT FOR MEALS & SUPPLIES PROVIDED DURING FIRE INCIDENTS	1,291.30
EFT36508	16/03/2023	BRIDGETOWN MITRE 10 & RETRAVISION	2 X 45KG GAS BOTTLES, 2 X RECHARGEABLE FLOODLIGHTS & MINOR ITEMS	675.66
EFT36509	16/03/2023	BRIDGETOWN NEWSAGENCY	MONTHLY NEWSPAPER CHARGES - FEBRUARY	114.80
EFT36510	16/03/2023	BRIDGETOWN TYRES	4 X NEW TYRES WITH ALIGNMENT, 1 X TYRE CHANGE & 20L GEAR OIL	2,568.00
EFT36511	16/03/2023	JOHN SYLVESTER CARROLL	RATES REFUND	836.62
EFT36512	16/03/2023	CITY AND REGIONAL FUELS	BULK FUEL SUPPLIES FOR DEPOT	9,276.56
EFT36513	16/03/2023	CJD EQUIPMENT PTY LTD	2 X 20L COOLANTS & VARIOUS PARTS FOR VOLVO WHEEL LOADER	970.59
EFT36514	16/03/2023	CLEANAWAY PTY LTD	WASTE COLLECTION SERVICES FOR FEBRUARY	31,671.58
EFT36515	16/03/2023	CLEANWAY XTRA CLEANING SERVICES	MONTHLY COURT CLEANING FOR BLC - FEBRUARY	821.56
EFT36516	16/03/2023	CORE BUSINESS AUSTRALIA PTY LTD	PREPARE & MANAGE TENDER FOR GREENBUSHES CAR PARK PROJECT	16,742.00

**SHIRE OF BRIDGETOWN-GREENBUSHES**  
**LIST OF ACCOUNTS PAID IN MARCH TO BE RECEIVED**

<b>Cheque/ Voucher No.</b>	<b>Date of Payment</b>	<b>Payee</b>	<b>Payment Description</b>	<b>Payment Amount \$</b>
EFT36517	16/03/2023	SRI ASTUTI CUNNINGHAM	PURCHASE OF PORTIONS OF LAND ON BLACKWOOD RD GREENBUSHES	34,674.50
EFT36518	16/03/2023	CUSTOM SERVICE LEASING LTD	CESM VEHICLE LEASING FOR MONTH OF MARCH	519.77
EFT36519	16/03/2023	CUTTS TRANSPORT PTY LTD	TRANSPORT OF NEW KERBSIDE BINS FROM PERTH TO BRIDGETOWN	495.00
EFT36520	16/03/2023	DAVMECH	REPLACE DUO CONE SEALS ON TRAXCAVATOR & SERVICE OF GRADER	6,656.81
EFT36521	16/03/2023	DAWN TAN LEGAL	LAND TRANSFER & SETTLEMENT COSTS FOR GREENBUSHES CAR PARK PROJECT	5,002.60
EFT36522	16/03/2023	DEPT OF PREMIER & CABINET - SLP	ADVERTISING IN THE GOVERNMENT GAZETTE - TPS 4 SCHEME AMENDMENT 72	124.80
EFT36523	16/03/2023	DIGGA WEST	1 X DIGGA ROAD BROOM BRUSH FOR STREET SWEEPER	946.00
EFT36524	16/03/2023	TESSA DITTRICH	REIMBURSEMENT OF GROCERIES	7.41
EFT36525	16/03/2023	ELECTRONIC SCOREBOARDS AUSTRALIA	MOUNTING BLOCK FOR ELECTRONIC SCOREBOARD AT BLC	87.89
EFT36526	16/03/2023	ENVIRO & AG TESTING SERVICES	LAB TESTING OF 2 X BORE SAMPLES FROM WASTE FACILITY	583.00
EFT36527	16/03/2023	ESTATE OF BRIAN ROBERT WHEATLEY	PURCHASE OF PORTIONS OF LAND ON HAMPTON ST	540.00
EFT36528	16/03/2023	FAIRTEL PTY LTD	TELEPHONE & NBN CHARGES FOR FEBRUARY	179.47
EFT36529	16/03/2023	DEPT FIRE & EMERGENCY SERVICES WA	2022/23 3RD QUARTER ESL CONTRIBUTION & RETURN OF UNSPENT GRANT	97,267.81
EFT36530	16/03/2023	FISHERS TYRE CENTRE	REPAIR TO ROAD ROLLER TYRE	77.00
EFT36531	16/03/2023	FREESTYLE NOW PROMOTIONS	ANNUAL YOUTH SKATEPARK COMPETITION EVENT	5,000.00
EFT36532	16/03/2023	FRESHWATER IRRIGATION	REPAIRS TO RETIC AT POOL & DAM PUMP FOR SPORTSGROUND	798.96
EFT36533	16/03/2023	FULTON HOGAN INDUSTRIES PTY LTD	600L CATEMUL FOR POTHOLE PATCHING	838.20
EFT36534	16/03/2023	ROBERT JOHN GREY	REFUND OF CAT TRAP BOND LESS HIRE FEES	28.00
EFT36535	16/03/2023	HANSEN'S HOT BREAD SHOP	MEALS FOR PERSONNEL ATTENDING INCIDENT & CATERING FOR MEETING	178.50
EFT36536	16/03/2023	RICHARD JOHN HARVEY	RATES REFUND	673.44
EFT36537	16/03/2023	H C JONES & CO	REPAIRS TO TOILETS AT GREENBUSHES CRICKET PAVILION & CIVIC CENTRE	540.50
EFT36538	16/03/2023	HILLVIEW ELECTRICAL SERVICE	EMERGENCY EXIT LIGHT TESTING FOR SHIRE BUILDINGS	2,750.00
EFT36539	16/03/2023	IEQUIP	MACHINE HIRE FOR BUSHFIRE MITIGATION	2,405.59
EFT36540	16/03/2023	INTERPHONE	MONTHLY INTERNET CHARGE FOR ADMIN OFFICE FOR MARCH	130.90
EFT36541	16/03/2023	IPEC PTY LTD	FREIGHT CHARGES	470.27
EFT36542	16/03/2023	IRIS CONSULTING GROUP PTY LTD	KEYWORDS FOR COUNCIL ONLINE TRAINING COURSE FOR 3 X STAFF	627.00
EFT36543	16/03/2023	IXOM OPERATIONS PTY LTD	MONTHLY RENTAL FOR 920KG CHLORINE GAS CYLINDER FOR FEBRUARY	157.39
EFT36544	16/03/2023	JASON SIGN MAKERS	1 X REFLECTIVE MUSTER SIGN FOR GREENBUSHES HALL	24.49
EFT36545	16/03/2023	JOHNSON'S FOOD SERVICES	VARIOUS SNACK & FROZEN FOODS FOR RESALE AT THE BLC CAFE	2,292.07
EFT36546	16/03/2023	LANDGATE	LAND VALUATION ENQUIRY CHARGES	113.95

**SHIRE OF BRIDGETOWN-GREENBUSHES**  
**LIST OF ACCOUNTS PAID IN MARCH TO BE RECEIVED**

<b>Cheque/ Voucher No.</b>	<b>Date of Payment</b>	<b>Payee</b>	<b>Payment Description</b>	<b>Payment Amount \$</b>
EFT36547	16/03/2023	LD TOTAL	BLACKWOOD RIVER FORESHORE PROJECT VARIATION - CLAIM 15	6,627.50
EFT36548	16/03/2023	LOCAL GOV SUPERVISORS ASSOC WA	ANNUAL LOCAL GOVERNMENT WORKS ASSOCIATION MEMBERSHIP	100.00
EFT36549	16/03/2023	MAIN ROADS WA	SHIRES CONTRIBUTION FOR SUBSTRUCTURAL REPAIRS ON SLADES RD BRIDGE	160,600.00
EFT36550	16/03/2023	MARKETFORCE	VARIOUS SHIRE ADVERTISEMENTS	2,164.14
EFT36551	16/03/2023	MICK TUCK GRADER SERVICES PTY LTD	HIRE OF GRADER AND OPERATOR FOR WINNEJUP ROAD WORKS	32,604.00
EFT36552	16/03/2023	NJ MECHANICAL	REPLACE OIL SENSOR ON YORNUP LIGHT TANKER	193.38
EFT36553	16/03/2023	OFFICEWORKS LTD	2 X LABEL WRITERS, 2 X KEYBOARD & MOUSE SETS & 1 X ANTI GLARE SCREEN	570.95
EFT36554	16/03/2023	PLATE PROVIDERS	100 X NUMBER PLATE FRAMES FOR VISITOR CENTRE STOCK	489.13
EFT36555	16/03/2023	PRESTBURY PARK SADDLERY	1 X PAIR OF CHAPS FOR SNAKE PROTECTION	69.99
EFT36556	16/03/2023	R & R PUBLICATIONS AUSTRALIA	BOOKS FOR VISITOR CENTRE STOCK	59.94
EFT36557	16/03/2023	RSL OF AUSTRALIA WA BRANCH	PURCHASE OF PORTION OF LAND ON BLACKWOOD RD GREENBUSHES	17,174.50
EFT36558	16/03/2023	RICHFEEDS AND RURAL SUPPLIERS	GARDENING CHEMICALS, IRRIGATION SUPPLIES & VARIOUS STAFF PPE	1,619.00
EFT36559	16/03/2023	THE ROYAL LIFE SAVING SOCIETY WA INC	1 X ATTENDANCE TO POOL LIFEGUARD COURSE	299.00
EFT36560	16/03/2023	SCAVENGER SUPPLIES PTY LTD	FIRE EXTINGUISHER SERVICING FOR SHIRE VEHICLES & FIRST AID KIT REFILLS	2,322.55
EFT36561	16/03/2023	SCHWEPPE AUSTRALIA PTY LTD	DRINKS FOR RESALE AT THE BLC CAFE	894.54
EFT36562	16/03/2023	SCOPE BUSINESS IMAGING	MONTHLY PHOTOCOPYING AND PRINTING CHARGES - FEBRUARY	978.77
EFT36563	16/03/2023	SEEK LIMITED	RECRUITMENT ADVERTISING	412.50
EFT36564	16/03/2023	SOUTHERN LOCK AND SECURITY	REPROGRAMMING OF LIBRARY SECURITY SYSTEM & LOCKS FOR CIVIC CENTRE	686.93
EFT36565	16/03/2023	SOUTH WEST FIRE UNITS	REPAIR AERIALS AND AIR HORN OF HESTER BROOK 2.4	1,345.25
EFT36566	16/03/2023	SOUTH WEST ISUZU	CYLINDER ASM CLUTCH MASTER PART FOR ISUZU TIP TRUCK	160.39
EFT36567	16/03/2023	SOUTH REGIONAL TAFE	1 X REGISTRATION TO AUSCHEM ACCREDITATION TRAINING & MANUAL	110.00
EFT36568	16/03/2023	SOUTHERN FOREST HOMES	DEPOSIT FOR SUPPLY & INSTALL OF LIQUID HOLDING TANK AT WASTE FACILITY	2,914.70
EFT36569	16/03/2023	SPRINT EXPRESS	FREIGHT CHARGES	42.90
EFT36570	16/03/2023	STEWART & HEATON CLOTHING CO	49 X SHIRE BRIDGETOWN-GREENBUSHES SHOULDER PATCHES FOR DFES PPE	426.35
EFT36571	16/03/2023	SYNERGY	ELECTRICITY CHARGES	15,504.32
EFT36572	16/03/2023	THE STABLES IGA	VARIOUS GROCERY SUPPLIES	199.64
EFT36573	16/03/2023	MARGARET THOMAS	RATES REFUND	341.45
EFT36574	16/03/2023	T-QUIP	REPLACEMENT SPRING TORSION FOR TORO ZERO TURN MOWER DECK	49.45
EFT36575	16/03/2023	TRAFFIC FORCE	TRAFFIC CONTROL FOR WINNEJUP ROAD WORKS	17,890.15
EFT36576	16/03/2023	WALGA	5 X ELECTED MEMBER ESSENTIAL TRAINING COURSES	1,540.00

**SHIRE OF BRIDGETOWN-GREENBUSHES**  
**LIST OF ACCOUNTS PAID IN MARCH TO BE RECEIVED**

<b>Cheque/ Voucher No.</b>	<b>Date of Payment</b>	<b>Payee</b>	<b>Payment Description</b>	<b>Payment Amount \$</b>
EFT36577	16/03/2023	WINC AUSTRALIA PTY LTD	DESKTOP RISER, ANTI FATIGUE MAT, BULK CLEANING SUPPLIES & MINOR ITEMS	1,762.34
EFT36578	16/03/2023	WREN OIL	ADMIN & COMPLIANCE FEE FOR COLLECTION OF WASTE OIL FOR RECYCLING	16.50
EFT36579	20/03/2023	AUSTRALIAN TAXATION OFFICE	BAS FOR FEBRUARY 2023	28,763.00
EFT36580	30/03/2023	JULIA ANN BOYLE	MONTHLY COUNCILLOR ALLOWANCE	1,013.83
EFT36581	30/03/2023	ELKE HELENE BROWNE	MONTHLY COUNCILLOR ALLOWANCE	1,013.83
EFT36582	30/03/2023	MIKKEL SKOU CHRISTENSEN	MONTHLY COUNCILLOR ALLOWANCE	1,013.83
EFT36583	30/03/2023	TRACY LANSDELL	MONTHLY COUNCILLOR ALLOWANCE	1,013.83
EFT36584	30/03/2023	SEAN MICHAEL MAHONEY	MONTHLY COUNCILLOR ALLOWANCE	1,487.35
EFT36585	30/03/2023	JENNIFER MARY MOUNTFORD	MONTHLY COUNCILLOR ALLOWANCE	3,367.91
EFT36586	30/03/2023	ANTONINO PRATICO	MONTHLY COUNCILLOR ALLOWANCE	1,013.83
EFT36587	30/03/2023	PETER SIMON QUINBY	MONTHLY COUNCILLOR ALLOWANCE	1,013.83
EFT36588	30/03/2023	EILEEN AMANDA ROSE	MONTHLY COUNCILLOR ALLOWANCE	1,013.83
EFT36589	31/03/2023	2R ELECTRICAL	REPLACE FLUORO LIGHTS WITH LED'S AT FIRE CONTROL CENTRE	330.00
EFT36590	31/03/2023	AJ & DS PAINTING	PREP & PAINT TROTTERING CLUB TOTE BUILDING	3,404.50
EFT36591	31/03/2023	ALICIA ROGERSON ART	FEES FOR WORKSHOP & GRAPHIC DESIGN FOR HARMONY WEEK BANNERS	2,970.00
EFT36592	31/03/2023	ARBOR GUY	WESTERN POWER POWERLINE TREE PRUNING	42,542.06
EFT36593	31/03/2023	ASK WASTE MANAGEMENT	WASTE SITE DEVELOPMENT REPORT - PART PAYMENT	8,357.25
EFT36594	31/03/2023	BLACKWOOD RURAL SERVICES	20L OIL FOR TRAXCAVATOR, CHAINSAW CHAINS & IRRIGATION SUPPLIES	485.00
EFT36595	31/03/2023	BLACKWOOD HEAVY TILT	TRANSPORT FORD RANGER TO REPAIRERS	220.00
EFT36596	31/03/2023	BLACKWOOD PROPERTY MAINTENANCE	GRAFFITI REMOVAL AT SKATE PARK & BLC & PRESSURE CLEAN PUBLIC TOILETS	726.58
EFT36597	31/03/2023	BRC BUILDING SOLUTIONS PTY LTD	BRIDGETOWN RAILWAY STATION CONSERVATION & RENEWAL PROJECT	74,437.00
EFT36598	31/03/2023	BRIDGETOWN MEDICAL CENTRE	PRE-EMPLOYMENT MEDICAL ASSESSMENT	135.00
EFT36599	31/03/2023	BRIDGETOWN MITRE 10 & RETRAVISION	VARIOUS MINOR PLUMBING AND HARDWARE ITEMS	73.75
EFT36600	31/03/2023	BRIDGETOWN PAINT SALES	PAINTING SUPPLIES FOR SPORTSGROUND TOILETS	342.20
EFT36601	31/03/2023	BRIDGETOWN TYRES	2 X NEW BATTERIES, 2 X TYRE REPLACEMENTS, TRAILER PLUG & PIN	1,215.50
EFT36602	31/03/2023	BRIDGETOWN HOME OF HEALTH	20 X BOTTLES OF SPF 30 MOTHER SUNSCREEN FOR WORKS STAFF	840.00
EFT36603	31/03/2023	BSA ADVANCED PROPERTY SOLUTIONS	INVESTIGATE AND REPAIR AIR CONDITIONING LEAK AT LIBRARY	418.00
EFT36604	31/03/2023	BCITF	BCITF LEVIES COLLECTED FOR THE MONTH OF FEBRUARY	91.75
EFT36605	31/03/2023	BUSSELTON BITUMEN SERVICE & CIVIL	SUPPLY & DELIVER ROE ST ASPHALT OVERLAY	49,184.44
EFT36606	31/03/2023	CJD EQUIPMENT PTY LTD	2 X SLIDE MEMBER SLEEVES FOR VOLVO GRADER	539.18

**SHIRE OF BRIDGETOWN-GREENBUSHES**  
**LIST OF ACCOUNTS PAID IN MARCH TO BE RECEIVED**

<b>Cheque/ Voucher No.</b>	<b>Date of Payment</b>	<b>Payee</b>	<b>Payment Description</b>	<b>Payment Amount \$</b>
EFT36607	31/03/2023	ELAINE MARGARET CLUCAS	REIMBURSEMENT OF PRE-EMPLOYMENT MEDICAL	130.00
EFT36608	31/03/2023	COMMERCIAL AQUATICS AUSTRALIA	INSTALLATION OF EMERGENCY CHLORINE LEAK DETECTORS AT BLC POOL	20,735.00
EFT36609	31/03/2023	CORE BUSINESS AUSTRALIA PTY LTD	PREPARE & MANAGE TENDER FOR GREENBUSHES CAR PARK PROJECT - CLAIM 2	1,738.00
EFT36610	31/03/2023	DAVMECH	DIAGNOSE & REPLACE HYDRAULIC HOSE ON CATERPILLAR BACKHOE LOADER	702.74
EFT36611	31/03/2023	DEPT WATER & ENVIROMENTAL REGS	ANNUAL LICENCE FEE FOR BRIDGETOWN LANDFILL SITE	1,303.50
EFT36612	31/03/2023	LGRCEU	PAYROLL DEDUCTIONS	132.00
EFT36613	31/03/2023	GE & CJ GIBLETT	HAZARD REDUCTION COMPLIANCE WORK FOR PRIVATE PROPERTY	330.00
EFT36614	31/03/2023	HARMONIC ENTERPRISES PTY LTD	IT LABOUR COSTS FOR MICROSOFT 365 MIGRATION	5,940.00
EFT36615	31/03/2023	H C JONES & CO	REPAIR HESTER BROOK BFB WATER PUMP & TESTING OF BACKFLOW DEVICES	808.50
EFT36616	31/03/2023	HILLVIEW ELECTRICAL SERVICE	NEW POWER OUTLET FOR CHLORINE GAS DETECTORS & INSTALL LED LIGHT	643.50
EFT36617	31/03/2023	ILLION TENDERLINK	PUBLIC TENDER ADVERTISING	181.50
EFT36618	31/03/2023	INDUSTRIAL AUTOMATION GROUP	SUPPLY 50 X STANDPIPE ACCESS CARDS	880.00
EFT36619	31/03/2023	IPEC PTY LTD	FREIGHT CHARGES	190.94
EFT36620	31/03/2023	ITR PACIFIC PTY LTD	3 X CUTTING EDGES FOR VOLVO WHEEL LOADER BUCKET	758.74
EFT36621	31/03/2023	JOHNSON'S FOOD SERVICES	SNACKS & FROZEN FOODS FOR RESALE AT THE BLC CAFE	1,121.56
EFT36622	31/03/2023	KEVIN FRANCIS KELLY	RATES REFUND	600.32
EFT36623	31/03/2023	LANDGATE	LAND VALUATION ENQUIRY CHARGES	802.36
EFT36624	31/03/2023	CHRISTINE MARY LATHAM	1 X ARTWORK DESIGN FOR CHRISTMAS BANNER	300.00
EFT36625	31/03/2023	BRENTON LINES	PAYMENT FOR UMPIRING OF VOLLEYBALL GAMES	120.00
EFT36626	31/03/2023	MOORE AUSTRALIA	REGISTRATION WALGA FBT WORKSHOP & GST WORKSHOP FOR 3 X STAFF	1,320.00
EFT36627	31/03/2023	MUIRS MANJIMUP	REPLACE INDICATOR GLOBE ON FORD EVEREST	28.55
EFT36628	31/03/2023	GARY ONLEY	REFUND OF EARTHWORKS BOND	600.00
EFT36629	31/03/2023	DARREN REEVES	MORTAR REPOINTING WORKS FOR SHIRE ADMIN BUILDING	11,000.00
EFT36630	31/03/2023	REPCO	TOOLS FOR FLEET MECHANIC	114.00
EFT36631	31/03/2023	PETER JAMES ROLLEY	REFUND OF APPLICATION FEES FOR CANCELLED BUILDING PERMIT	171.65
EFT36632	31/03/2023	RYNAT INDUSTRIES AUSTRALIA PTY LTD	13 X TWIN ROLL TOILET PAPER DISPENSERS FOR VARIOUS PUBLIC TOILETS	5,187.00
EFT36633	31/03/2023	SCHWEPPE AUSTRALIA PTY LTD	VARIOUS DRINKS FOR RESALE AT THE BLC CAFE	740.28
EFT36634	31/03/2023	SCULLEY'S SMASH REPAIRS	INSURANCE POLICY EXCESS FOR NISSAN NAVARA	300.00
EFT36635	31/03/2023	SOUTHERN LOCK AND SECURITY	DEADBOLT KEYED TO SHIRE SYSTEM FOR GREENBUSHES SPORTSGROUND	253.47
EFT36636	31/03/2023	SOUTH WEST ISUZU	105,000KM SERVICE FOR ISUZU TRUCK	1,266.08

**SHIRE OF BRIDGETOWN-GREENBUSHES**  
**LIST OF ACCOUNTS PAID IN MARCH TO BE RECEIVED**

<b>Cheque/ Voucher No.</b>	<b>Date of Payment</b>	<b>Payee</b>	<b>Payment Description</b>	<b>Payment Amount \$</b>
EFT36637	31/03/2023	SOUTH WEST OIL SUPPLIES	24 X 450G MOBIL GREASE, 1 X 20L DEGREASER & 15KG OF RAGS	349.75
EFT36638	31/03/2023	SOURCE MY PARTS PTY LTD	2 X SLIDE MEMBER SLEEVES FOR VOLVO GRADER	499.07
EFT36639	31/03/2023	SYNERGY	ELECTRICITY CHARGES	8,694.39
EFT36640	31/03/2023	TECHXPRESS PTY LTD	300 X DISPOSABLE HEADPHONES & EARPHONES FOR RESALE AT LIBRARY	396.00
EFT36641	31/03/2023	TPG NETWORK PTY LTD	MONTHLY INTERNET CHARGES FOR LIBRARY & DEPOT FOR MARCH	290.40
EFT36642	31/03/2023	TRAFFIC FORCE	TRAFFIC CONTROL FOR WINNEJUP ROAD & ANNUAL REVIEW OF SHIRES TMP	10,200.27
EFT36643	31/03/2023	WA NATURALLY PUBLICATIONS	CALENDARS & BOOKS FOR VISITOR CENTRE STOCK	161.81
EFT36644	31/03/2023	WARREN PEST CONTROL	PEST INSPECTIONS FOR SHIRE BRIDGES & 2 X TERMITE TREATMENTS	3,696.00
EFT36645	31/03/2023	WESTRAC PTY LTD	REPAIR LOOSE TRACK SHOE ON TRAXCAVATOR	203.05
EFT36646	31/03/2023	WINC AUSTRALIA PTY LTD	STATIONERY, LIBRARY COFFEE MACHINE SUPPLIES & BULK CLEANING SUPPLIES	2,822.37
EFT36647	31/03/2023	DEPT MINES, INDUSTRY REGS & SAFETY	BSL'S COLLECTED FOR FEBRUARY	1,913.15
<b>DIRECT DEBITS - LICENSING</b>				
27616	01/03/2023	DEPARTMENT OF TRANSPORT	LICENSING PAYMENTS FOR 01/03/2023	3,616.75
27617	02/03/2023	DEPARTMENT OF TRANSPORT	LICENSING PAYMENTS FOR 02/03/2023	7,150.30
27618	03/03/2023	DEPARTMENT OF TRANSPORT	LICENSING PAYMENTS FOR 03/03/2023	4,413.10
27619	07/03/2023	DEPARTMENT OF TRANSPORT	LICENSING PAYMENTS FOR 07/03/2023	5,245.05
27620	08/03/2023	DEPARTMENT OF TRANSPORT	LICENSING PAYMENTS FOR 08/03/2023	6,979.40
27621	09/03/2023	DEPARTMENT OF TRANSPORT	LICENSING PAYMENTS FOR 09/03/2023	1,040.50
27622	10/03/2023	DEPARTMENT OF TRANSPORT	LICENSING PAYMENTS FOR 10/03/2023	6,058.20
27623	13/03/2023	DEPARTMENT OF TRANSPORT	LICENSING PAYMENTS FOR 13/03/2023	6,855.00
27624	14/03/2023	DEPARTMENT OF TRANSPORT	LICENSING PAYMENTS FOR 14/03/2023	5,406.45
27625	15/03/2023	DEPARTMENT OF TRANSPORT	LICENSING PAYMENTS FOR 15/03/2023	4,438.35
27626	16/03/2023	DEPARTMENT OF TRANSPORT	LICENSING PAYMENTS FOR 16/03/2023	8,132.85
27627	17/03/2023	DEPARTMENT OF TRANSPORT	LICENSING PAYMENTS FOR 17/03/2023	4,935.90
27628	20/03/2023	DEPARTMENT OF TRANSPORT	LICENSING PAYMENTS FOR 20/03/2023	8,485.35
27629	21/03/2023	DEPARTMENT OF TRANSPORT	LICENSING PAYMENTS FOR 21/03/2023	3,643.95
27630	22/03/2023	DEPARTMENT OF TRANSPORT	LICENSING PAYMENTS FOR 22/03/2023	3,149.75
27631	23/03/2023	DEPARTMENT OF TRANSPORT	LICENSING PAYMENTS FOR 23/03/2023	2,625.05
27632	24/03/2023	DEPARTMENT OF TRANSPORT	LICENSING PAYMENTS FOR 24/03/2023	3,764.00
27633	27/03/2023	DEPARTMENT OF TRANSPORT	LICENSING PAYMENTS FOR 27/03/2023	6,394.65

**SHIRE OF BRIDGETOWN-GREENBUSHES**  
**LIST OF ACCOUNTS PAID IN MARCH TO BE RECEIVED**

<b>Cheque/ Voucher No.</b>	<b>Date of Payment</b>	<b>Payee</b>	<b>Payment Description</b>	<b>Payment Amount \$</b>
27634	28/03/2023	DEPARTMENT OF TRANSPORT	LICENSING PAYMENTS FOR 28/03/2023	2,300.10
27635	29/03/2023	DEPARTMENT OF TRANSPORT	LICENSING PAYMENTS FOR 29/03/2023	6,758.70
27636	30/03/2023	DEPARTMENT OF TRANSPORT	LICENSING PAYMENTS FOR 30/03/2023	5,680.25
27637	31/03/2023	DEPARTMENT OF TRANSPORT	LICENSING PAYMENTS FOR 31/03/2023	4,306.50
<b>CHEQUES</b>				
300242	08/03/2023	PETER GAVIN WILKINSON	REFUND OF STANDPIPE BOND & REMAINING WATER CREDIT	170.88
300243	31/03/2023	BUNNINGS TRADE	1 X OXY ACETYLENE CYLINDER INC DEPOSIT AND CUTTING & BRAZING KIT	753.10
300244	31/03/2023	DEPARTMENT OF TRANSPORT	VEHICLE REGISTRATIONS	243.50
300245	31/03/2023	SHIRE OF BRIDGETOWN-GREENBUSHES	SHIRES COMMISSIONS FOR THE MONTH OF FEBRUARY	78.25
300246	31/03/2023	WATER CORPORATION	WATER USAGE CHARGES	3,916.32
				<b>1,837,230.51</b>
<b>CHEQUES - VISITOR CENTRE TRUST</b>				
200042	15/03/2023	SHIRE OF BRIDGETOWN-GREENBUSHES	SHIRES COMMISSIONS FOR THE MONTH OF FEBRUARY	292.59
<b>ELECTRONIC PAYMENTS - VISITOR CENTRE TRUST</b>				
EFT36481	15/03/2023	KEN ADAM	ACCOMMODATION REFUND LESS CANCELLATION FEE	298.00
EFT36482	15/03/2023	BRIDGETOWN HISTORICAL SOCIETY INC.	CONSIGNMENT STOCK SOLD FOR FEBRUARY 2023	28.12
EFT36483	15/03/2023	BGBTA	CONSIGNMENT STOCK SOLD FOR FEBRUARY 2023	51.00
EFT36484	15/03/2023	ANNE HARSE	CONSIGNMENT STOCK SOLD FOR FEBRUARY 2023	33.75
EFT36485	15/03/2023	JENNIFER MARY MOUNTFORD	CONSIGNMENT STOCK SOLD FOR FEBRUARY 2023	11.25
EFT36486	15/03/2023	PUBLIC TRANSPORT AUTHORITY OF WA	BUS TICKETS SOLD FOR FEBRUARY 2023	256.56
EFT36487	15/03/2023	WA HOLIDAY GUIDE PTY LTD	COMMISSION ON ACCOMMODATION BOOKINGS FOR FEBRUARY 2023	7.02
V300222	09/03/2023	WESTPAC	TOTAL ACCOMMODATION FOR THE MONTH OF FEBRUARY 2023	1,328.01
				<b>2,306.30</b>



**SHIRE OF BRIDGETOWN-GREENBUSHES**  
**LIST OF ACCOUNTS PAID IN MARCH TO BE RECEIVED**

<b>Cheque/ Voucher No.</b>	<b>Date of Payment</b>	<b>Payee</b>	<b>Payment Description</b>	<b>Payment Amount \$</b>
--------------------------------	----------------------------	--------------	----------------------------	----------------------------------

This schedule of accounts paid for the Municipal Fund totalling \$1,837,230.51 and for the Trust Fund totalling \$2,306.30 which was submitted to each member of the Council on 27th April 2023 has been checked and is fully supported by vouchers and invoices which are submitted herewith and which have been duly certified as to the receipt of goods and the rendition of services and as to prices, computations and castings.

Total creditor accounts outstanding as at 31/03/2023 is \$520,200.48



.....  
CHIEF EXECUTIVE OFFICER

27th April 2023

In accordance with Council Policy 'F.23 - Budget Management' the following budget adjustments are recommended.

**Determined by the CEO and Subsequently Reported to Council**

Budget overspends can be approved by the CEO at general ledger or job level for amounts up to \$20,000 or 20% whichever is the lesser.

General Ledger Account	General Ledger Account Description	General Ledger Current Budget	Job Number	Job Description	Expenditure or Income Type	Current Budget	Overspend and Proposed Offset Amounts	New Budget	Budget Variation Explanation
1250420	Sanitation Refuse Recycling	\$80,422	02YB	Refuse Recycling	Materials & Contracts	\$80,422	\$10,000	\$90,422	Increase in recycling materials being received at the waste site leading to increased transport and processing costs of this increase in tonnage.
1255030	Sanitation General User Pay Charges	-\$60,000			Other Fees & Charges	-\$60,000	-\$10,000	-\$70,000	Additional income anticipated due to the increase in disposal of waste at the Bridgetown Waste Site.
					<b>Totals</b>	<b>\$20,422</b>	<b>\$0</b>	<b>\$20,422</b>	

**SHIRE OF BRIDGETOWN-GREENBUSHES  
BUDGET MANAGEMENT REPORT - MARCH 2023**

**Authorised by the Shire President**

Section 6.8 (1)(c) of the Local Government Act 1995 provides for additional purpose expenditure when authorised in advance by the Shire President in an emergency.

General Ledger Account	General Ledger Account Description	General Ledger Account Current Budget	Job Number	Job Description	Expenditure or Income Type	Expenditure Amount	Emergency Expenditure Explanation
	Nil						
					<b>Total</b>	<b>\$0</b>	

**Council Budget Amendments**

Expenditure above the current budget and outside the parameters set in policy F.23 - Budget Management, or any expenditure at all for an additional purpose, requires a variation to the budget to be decided by the Council before funds are committed.

General Ledger Account	General Ledger Account Description	General Ledger Current Budget	Job Number	Job Description	Expenditure or Income Type	Current Budget	Overspend and Proposed Offset Amounts	New Budget	Budget Amendment Request Explanation
1349140	Other Recreation & Sport - Other Infrastructure	\$984,708	22IN	Major Strategic Project - Greenbushes Youth Precinct	Materials & Contracts	\$483,105	\$35,000	\$518,105	Allocation for contingency and project management costs. Previously referenced in Council resolution SpC.03/0223 however project expenditure amount was not increased in the resolution.
Reserve	Strategic Projects Reserve	\$237,863			Reserve Funds	\$237,863	-\$35,000	\$202,863	Transfer from Reserve to fund contingency and project management costs of the Greenbushes Youth Precinct as authorised in Council resolution SpC.03/0223.
					<b>Totals</b>	<b>\$720,968</b>	<b>\$0</b>	<b>\$720,968</b>	

# GREENBUSHES SKATEPARK

## ISSUE FOR: REVIEW

### SKATEPARK DESIGN CONSULTANT

SKATE SCULPTURE  
 1 HOWLETT ST  
 NORTH PERTH WA 6006  
 0450 405 510

### LOCATION

GREENBUSHES, WA

Attachment 11

DRAWING INDEX	
Sheet Number	Sheet Title
GRB-SP-000	COVER
GRB-SP-00N	GENERAL NOTES
GRB-SP-L01	SITE PLAN
GRB-SP-L03.1	GRADING PLAN
GRB-SP-L04.1	SETOUT PLAN PLAN
GRB-SP-L05.1	DIMENSIONS PLAN
GRB-SP-L06.1	FINISHES PLAN
GRB-SP-L07.1	JOINT PLAN
GRB-SP-L08.1	STEEL PLAN
GRB-SP-S01.1	SECTIONS
GRB-SP-D01	DETAILS (SHEET 1)
GRB-SP-D02	DETAILS (SHEET 2)
GRB-SP-D03	DETAILS (SHEET 3)

DESIGN BY (SKATEPARK)

SKATE SCULPTURE



0450405510  
 ABN: 82 399 521 292  
 info@skatesculpture.com.au  
 1 Howlett St, North Perth WA, 6006

STRUCTURAL ENGINEER STAMP

THE CONCEPTS ON AND CONTENT OF THIS DRAWING REMAIN THE PROPERTY OF SKATE SCULPTURE. THIS DRAWING SHALL ONLY BE USED FOR THE PURPOSE FOR WHICH IT WAS ASSIGNED. UNAUTHORIZED RETENTION, USE OR COPYING OF THIS DOCUMENT OR ITS CONTENTS IS PROHIBITED.  
 SKATE SCULPTURE ACCEPTS NO RESPONSIBILITY OR LIABILITY FOR ANY ACTION / CONSEQUENCE FROM THE UNAUTHORIZED USE OR MISUSE OF THIS DRAWING AND ITS CONTENTS OR ANY ALTERATIONS OR AMENDMENTS MADE BY OTHER PARTIES. THIS DRAWING AND ITS CONTENTS SHALL BE DEEMED CONFIDENTIAL UNLESS AGREED WITH SKATE SCULPTURE.



ISSUED FOR:

A 21.04.2023 PRELIMINARY

SIGNATURE OF AUTHORITY

THIS DRAWING IS NOT AUTHORISED FOR TENDER UNLESS SIGNED BY PRIMARY CONTACT HERE.  
 \_\_\_\_\_  
THIS DRAWING IS NOT AUTHORISED FOR CONSTRUCTION UNLESS SIGNED BY PRIMARY CONTACT HERE.

PROJECT  
 GREENBUSHES SKATEPARK

CLIENT / LGA

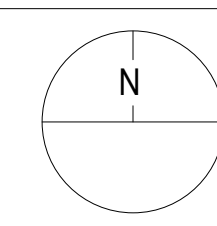

SCALE @ A1:  
 NTS

COVER

DRAWING NUMBER:  
 GRB-SP-000

REV  
 A

## STRUCTURAL NOTES:

### GENERAL:

- G1. DRAWINGS TO READ IN CONJUNCTION WITH ALL ARCHITECTURAL AND ALL OTHER RELEVANT CONSULTANT'S DRAWINGS AND THE SPECIFICATION.
- G2. THE BUILDER AND/OR CONTRACTORS AND THEIR SUB-CONTRACTORS SHALL ENSURE ALL WORK COMPLIES WITH THE LATEST B.L.A. AND AS/NZS CODES (AND AMENDMENTS) AND B.L.A. REQUIREMENTS.
- G3. ALL CODES REFERRED TO IN THESE NOTES AND THESE DRAWINGS SHALL BE THE CURRENT PUBLICATIONS INCLUDING THEIR LATEST REVISIONS.
- G4. DETAILS SHOWN SHALL BE TYPICAL ONLY.
- G5. THE BUILDER IS TO ALLOW FOR COSTS OF ALL SITE INSPECTIONS BY THE STRUCTURAL ENGINEER REQUIRED THROUGH THE COURSE OF CONSTRUCTION. NOTIFY PROJECT LEAD CONSULTANT AT LEAST 2 WORKING DAYS PRIOR TO ANY REQUIRED INSPECTIONS. ANY CERTIFICATES REQUIRED TO SATISFY LOCAL AUTHORITY REQUIREMENTS WILL NOT BE ISSUED WITHOUT INSPECTIONS TAKING PLACE.
- G6. ANY DISCREPANCIES BETWEEN THIS STRUCTURAL DOCUMENTATION AND ARCHITECTURAL DOCUMENTATION WITH STRUCTURAL IMPLICATIONS ARE TO BE CLARIFIED WITH PROJECT LEAD CONSULTANT PRIOR TO PRICING/DETAILING/CONSTRUCTION. ALL OTHER DISCREPANCIES TO BE CLARIFIED WITH ARCHITECT.
- G7. DO NOT SCALE OFF DRAWINGS OR SKETCHES. ALL DIMENSIONS TO BE TAKEN DIRECTLY FROM THE CURRENT ARCHITECTURAL DRAWINGS.
- G8. ALL DIMENSIONS RELEVANT TO SETTING OUT AND OFFSITE WORKS TO BE CONFIRMED WITH ARCHITECTURAL DRAWINGS BY BUILDER PRIOR TO COMMENCING CONSTRUCTION.ALL SITE LEVELS TO BE CHECKED ON SITE PRIOR TO THE COMMENCEMENT OF ANY WORK. REFER TO PROJECT LEAD CONSULTANT'S ENGINEER FOR DIRECTION IF ANY DETAILS REQUIRE REVIEW.
- G9. DIMENSIONS SHOWN ON ENGINEERING DRAWINGS ARE STRICTLY MINIMUM REQUIREMENTS AND ARE EXCLUSIVE OF ALL FALLS, RECESSES, GROOVES, TOPPINGS, SCREEDS, RENDERS, FINISHES, AND THE LIKE.
- G10. MAKE DUE ALLOWANCES IN FINISHES FOR DIFFERENTIAL MOVEMENT OF ALL MATERIALS OF CONSTRUCTION AND WHERE DIFFERING CONSTRUCTION MATERIALS OF CONSTRUCTION ARE IN CONTACT.
- G11. ALL TOPPINGS, SCREEDS, RENDERS, COVERINGS, COATINGS, MEMBRANES, CLADDINGS, FINISHES AND THE LIKE SHALL MAKE ALLOWANCE FOR MATERIAL CREEP, SHRINKAGE, THERMAL EXPANSION, DEFLECTION MOVEMENTS AND THE LIKE FOR THE LIFETIME OF THE STRUCTURE.
- G12. ALL THIRD PARTY /PROPRIETARY PRODUCTS ARE TO BE INSTALLED STRICTLY IN ACCORDANCE WITH SUPPLIER'S/MANUFACTURER'S SPECIFICATIONS AND DETAILS.
- G13. WHERE SPECIFIC PROPRIETARY PRODUCTS ARE NOMINATED, THE BUILDER MAY USE EQUIVALENT PRODUCTS ONLY WITH WRITTEN APPROVAL FROM PROJECT LEAD CONSULTANT. ALL SUBSTITUTED PROPRIETARY PRODUCTS TO BE OF EQUAL OR GREATER PERFORMANCE.

## SITE & CONSTRUCTION SAFETY:

- S1. SITE AND CONSTRUCTION SAFETY IS THE RESPONSIBILITY OF THE BUILDER.
- S2. THE BUILDER SHALL IDENTIFY ANY HAZARDS RELATING TO THE CONSTRUCTION OF THE STRUCTURE AND PUT SUFFICIENT MEASURES IN PLACE TO CONTROL THESE RISKS, INCLUDING COMPLETING ALL NECESSARY JOB SAFETY ANALYSIS SAFETY SHEETS.
- S3. THE BUILDER SHALL ENSURE ALL METHODS OF CONSTRUCTION MEET THE REQUIREMENTS OF WORKSAFE AND ALL RELEVANT OCCUPATIONAL HEALTH AND SAFETY REGULATIONS AND LEGISLATION THROUGH OUT ALL STAGES OF CONSTRUCTION.

## DESIGN CRITERIA:

01. SOIL CLASSIFICATION : CLASS 'S' WITH: MIN 150KPa ALLOWABLE BEARING CAR BBR 12%

## EARTHWORKS:

- E1 ALL EARTHWORKS ARE TO BE CARRIED OUT IN ACCORDANCE WITH PROJECT SPECIFIC GEOTECHNICAL REPORT, RELEVANT 'STANDARDS AUSTRALIA' CODES AND THE B.C.A. REQUIREMENTS.
- E2. REMOVE ANY TREE STUMPS, RUBBISH, ETC AND REPLACE WITH CLEAN COMPACTED SAND FILL. ENSURE NO VEGETATION OR ORGANIC MATTER EXISTS IN THE SOIL STRATA FOR A DEPTH OF AT LEAST 1000mm BELOW FOOTINGS AND 2000mm WIDER THAN THE BUILDING FOOTPRINT.
- E3. THE BUILDER IS TO STRICTLY FOLLOW ALL SITE PREPARATIONS REQUIREMENTS STATED IN THE GEOTECHNICAL ENGINEER'S REPORT. REFER PROJECT GEOTECHNICAL ENGINEER FOR CLARIFICATION
- E4. ALL GRANULAR SOIL (SAND) COMPACTION TESTS TO BE CARRIED OUT USING A STANDARD FALLING WEIGHT (PERTH) PENETROMETER.
- E5. ALL SAND UNDER THE STRUCTURE SHALL COMPACTED TO A MINIMUM OF NUMBER OF PENETROMETER BLOWS PER 300mm (TESTED TO SPECIFIED LEVEL BELOW BASE OF NEW FOOTING IN UNDISTURBED IN-SITU SOIL AND THE FULL DEPTH OF ALL FILL MATERIAL) AS FOLLOWS:  
FOOTING TYPE BLOWS PER 300mm TESTING DEPTH  
SLABS & STRIP FOOTINGS 8 BLOWS (PER 300mm), 750mm TESTING DEPTH OR AS PER THE REQUIREMENTS OF THE GEOTECHNICAL ENGINEERING REPORT.
- E6. THE BUILDER IS RESPONSIBLE FOR SELECTING AND PERFORMING AN APPROPRIATE COMPACTION METHOD TO ACHIEVE THE ABOVE STATED COMPACTION REQUIREMENTS. DO NOT USE COMPACTION METHODS THAT MAY CAUSE DAMAGE TO NEIGHBOURING STRUCTURES.
- E7. RE-COMPACT ANY LOOSE SAND PLACED UNDER AREA OF GROUND SLAB DUE TO EXCAVATION OF FOOTINGS OR LEVELING OF SAND PAD.
- E8. IT IS THE BUILDER'S RESPONSIBILITY TO ARRANGE FOR COMPACTION TESTING AND ARRANGE CERTIFICATION AS REQUIRED BY THE RELEVANT LOCAL BUILDING AUTHORITY.
- E9. COMPACTION CERTIFICATES SHALL BE SUBMITTED TO THE ENGINEER FOR APPROVAL BEFORE POURING OF ANY CONCRETE.
- E10. THE BUILDER IS TO ENSURE ALL STORM WATER AND SITE DRAINAGE IS LOCATED/INSTALLED IN A MANNER THAT WILL HAVE NO IMPACT ON ANY NEW OR EXISTING STRUCTURES DURING CONSTRUCTION/INSTALLATION/USAGE.
- E11. THE BUILDER IS RESPONSIBLE FOR SELECTING APPROPRIATE SHEET PILING/SHORING METHODS ON ANY BOUNDARIES OR WITHIN THE WORKS. ALL PILING IS TO BE DESIGNED AND CERTIFIED BY SPECIALIST SUB-CONTRACTOR'S PRACTICING ENGINEER. REFER TO SPECIFIC PILING NOTES (ON THIS PAGE - INCLUDED AS APPLICABLE).
- E12. BUILDER IS TO ALLOW FOR SITE VISIT BY PROJECT LEAD CONSULTANT'S ENGINEER FOR DIRECTION AS REQUIRED TO DISCUSS SUITABILITY OF SELECTED SHORING/PILING METHOD PRIOR TO COMMENCING WORKS OR AS REQUIRED.

## FOUNDATIONS AND GROUND SLABS:

- F1. FOOTINGS/GROUND SLABS HAVE BEEN DESIGNED BY SKATE SCULPTURE'S APPOINTED STRUCTURAL ENGINEER TO SUIT A CLASS "S" SITE IN ACCORDANCE WITH GEOTECHNICAL ENGINEER'S REPORT.
- F2. ALL EARTHWORKS/SITE PREPARATION TO BE PERFORMED AS PER GEOTECHNICAL ENGINEER'S REPORT/RECOMMENDATIONS. PROVIDE FULLY COMPACTED SUB-BASE ON SUB-GRADE TO ARCH'L SPECIFICATIONS.
- F3. LOCATE FOOTINGS CENTRALLY UNDER WALLS AND COLUMNS UNLESS INDICATED OTHERWISE ON TYPICAL SECTIONS.
- F4. THE LEVEL DIFFERENCE BETWEEN ADJOINING FOOTINGS SHALL NOT EXCEED ONE HALF OF THE CLEAR DISTANCE BETWEEN THEM.
- F5. THE BUILDER IS TO CONFIRM POSITION AND DEPTH OF ALL FOOTING STEPS (WHETHER SHOWN ON THESE DRAWINGS OR NOT) ON SITE TO COMPLY WITH FINISHED GROUND AND FLOOR LEVELS).
- F6. PROVIDE AN APPROVED MOISTURE PROOF MEMBRANE UNDER ALL GROUND SLABS OR AS SHOWN ON THESE DRAWINGS.
- F7. ALL TRENCH MESH AND GROUND SLAB MESH TOP BE LAPPED FOR A MINIMUM LENGTH OF 2 BARS + 25mm. EG: SL62 MESH LAPPED 225mm (MINIMUM).
- F8. ALL CONSTRUCTION JOINTS IN GROUND SLABS TO BE IN THE LOCATIONS SHOWN IN THESE DRAWINGS OR AS APPROVED BY THE ENGINEER.

## CONCRETE:

- C1. ALL MATERIALS AND WORKMANSHIP TO BE IN ACCORDANCE WITH ALL RELEVANT 'STANDARDS AUSTRALIA' CODES AND THE B.L.A. REQUIREMENTS.
- C2. ALL CEMENT TO BE TYPE 'A' PORTLAND CEMENT (U.N.O.), PROVIDED BY AN APPROVED PREMIXING COMPANY.
- C3. DO NOT USE BLENDED CEMENTS WITHOUT PRIOR WRITTEN AUTHORIZATION FROM PROJECT LEAD CONSULTANT.
- C4. CONCRETE SHALL BE SUPPLIED BY AN APPROVED READY-MIX COMPANY AND CONFORM TO THE FOLLOWING MINIMUM REQUIREMENTS (UNLESS NOTED OTHERWISE):

COMPONENT	GRADE	SLUMP	MAX AGG. SIZE
FOOTINGS:	N32	80MM	30MM
GROUND SLABS	N32	80MM	20MM
WALLS / SKATE FEATURES	N32	80MM	10MM

- C5. ALL CONCRETE TO BE PLACED WITH A MECHANICAL VIBRATOR.
- C6. ALL CONCRETE SHALL BE KEPT MOIST FOR A MINIMUM OF SEVEN (7) DAYS AFTER POURING BY PONDING OR OTHER APPROVED MEANS.
- C7. ALL FORMWORK TO COMPLY WITH AS 1509.
- C8. MINIMUM FORMWORK STRIPPING TIMES UNLESS NOTED OTHERWISE:  
WALLS: 3 DAYS,  
SLABS: 10 DAYS
- C9. WHERE CONCRETE IS DAMAGED AND/OR HONEY COMBED, NOTIFY PROJECT LEAD CONSULTANT FOR REPAIR REQUIREMENTS OR REMOVAL.
- C10. ALL EXPOSED CONCRETE EDGES WITHOUT CAST-IN SHS's ARE TO HAVE A 20mm CHAMFER EXCEPT UPPER EDGES WHICH ARE TO HAVE A 10mm BULLNOSE RADIUS.

## REINFORCEMENT:

- R1. ALL REINFORCEMENT IS TO BE SUPPLIED AND PLACED ACCORDANCE WITH ALL RELEVANT 'STANDARDS AUSTRALIA' CODES AND THE B.L.A. REQUIREMENTS,
- R2. BUILDER IS TO NOTIFY PROJECT LEAD CONSULTANT 2 DAYS IN ADVANCE OF POURING CONCRETE IF STEEL REINFORCING INSPECTION IS REQUIRED TO MEET LOCAL BUILDING AUTHORITY REQUIREMENTS, NO CERTIFICATION WILL BE ISSUED WITHOUT INSPECTION,
- R3. ALL REINFORCEMENT BARS TO BE FREE OF SCALE, RUST AND OTHER MATTER,
- R4. BAR NOTATIONS ON DRAWINGS DENOTE THE FOLLOWING:  
N - DENOTES GRADE D500N HOT ROLLED RIBBED REBARS  
S - DENOTES GRADE D250N HOT ROLLED RIBBED REBARS  
R - DENOTES GRADE R250N HOT ROLLED PLAIN ROUND BARS  
W - DENOTES GRADE R500L COLD DRAWN ROUND WIRE  
DW - DENOTES GRADE D500L COLD ROLLED RIBBED WIRE  
SL - DENOTES SQUARE MESH  
RL - DENOTES RECTANGULAR  
TM - DENOTES TRENCH MESH
- R5. PROVIDE 1-N16 REINFORCING BAR x 1500 LONG TOP & BOTTOM OF SLAB AT ALL RE-ENTRANT CORNERS (UNLESS NOTED OTHERWISE) WHETHER SHOWN ON PLAN OR NOT,
- R6. SUPPORT AND TIE ALL REINFORCEMENT TO MAINTAIN SPECIFIED COVER ON APPROVED PLASTIC OR PLASTIC TIPPED STEEL CHAIRS AT 1000mm MAXIMUM CENTERS,
- R7. ALL BAR SPLICE LENGTHS OF DEFORMED BARS TO BE 40 x BAR DIAMETERS AND SHEETS OF MESH TO OVERLAP BY A MINIMUM OF TWO WIRES + 25mm (UNLESS NOTED OTHERWISE),
- R8. SLOPES OF CRANKED BARS SHALL NOT EXCEED ONE IN SIX,
- R9. MINIMUM CLEAR COVER TO REINFORCEMENT TO BE AS FOLLOWS (UNLESS NOTED OTHERWISE):

COMPONENT	INTERNAL COVER	EXTERNAL COVER (EXPOSED)
GROUND SLABS:	-	40MM
WALLS:	-	40MM
FOOTINGS:	75MM	75MM

- R10. THE BUILDER IS TO ENSURE THAT ALL BARS SHALL AT ALL TIMES BE PLACED IN THE EXTREME CORNERS OF LIGATURES TO BEAMS AND COLUMNS,

## STEELWORK:

- S1. ALL STEELWORK TO BE SUPPLIED/FABRICATED/WELDED/TRANSPORTED/ERECTED CORROSION PROTECTED IN ACCORDANCE WITH ALL RELEVANT 'STANDARDS AUSTRALIA' CODES AND THE B.L.A. REQUIREMENTS.
- S2. ALL COLD FORMED STEEL MEMBERS, CONNECTIONS, BRACING, ETC, SHALL CONFORM WITH ALL RELEVANT 'STANDARDS AUSTRALIA' CODES AND THE MANUFACTURER'S WRITTEN INSTRUCTIONS.
- S3. MINIMUM WELDED REQUIREMENTS ARE 6mm CONTINUOUS FILLET WELDS UNLESS NOTED OTHERWISE ON THESE DRAWINGS. WELDS TO DEVELOP FULL STRENGTH OF THE MEMBERS TO BE JOINED.
- S4. VERIFY ALL SETOUT DIMENSIONS WITH ARCHITECTURAL DRAWINGS. DO NOT SCALE FROM STRUCTURAL DRAWINGS.
- S5. PROVIDE ALL CLEATS, BRACKETS, WELDING AND HOLING, ETC NECESSARY FOR THE COMPLETION OF THE BUILDING AND AS SHOWN AND REQUIRED TO SUIT ARCHITECTURAL DETAILS. SHOP DETAILER TO PROVIDE HOLES TO STEEL MEMBERS TO ALLOW FOR FIXING OF NON STRUCTURAL COMPONENTS IN ACCORDANCE WITH ARCHITECTURAL DETAILS.
- S6. FULLY SEAL ALL HOLLOW SECTIONS USING 5mm PLATES UNLESS NOTED OTHERWISE.
- S7. ALL STEELWORK TO BE FREE FROM DISTORTIONS WITH ALL NATURAL CAMBERS IN STEELWORK TO BE UPWARDS.
- S8. MEMBERS SHALL BE IN ONE LENGTH, UNLESS OTHERWISE APPROVED.
- S9. ALL BOLTS, NUTS AND WASHERS TO BE CADMIUM PLATED. ALL EXTERNAL BOLTING AND HOLDING DOWN BOLTS, NUTS AND WASHERS TO BE HOT DIPPED GALVANIZED UNLESS NOTED OTHERWISE.
- S10. MINIMUM STEELWORK FINISHES SHALL BE:  
i) ALL SUPPLIED CHS/SHS SECTIONS TO BE DURAGAL.  
ii) SITE TREAT ANY DAMAGED CORROSION PROTECTION (DUE TO WELDING/CUTTING/ GRINDING, ETC) WITH 'GALMET' SILVER PAINT (APPLICATION TO BE NEAT & CONSISTENT).  
iii) TREAT STEELWORK BELOW GROUND LEVEL WITH 2 COATS OF TAUBMANS INTERZONE 954 EPOXY (TO ACHIEVE A MINIMUM OF 150 MICRONS COVER) OR APPROVED EQUIVALENT.

## CAST-IN SHS/CHS STEEL SECTIONS:

- S1. ALL SHS/CHS CAST-IN STEEL SECTIONS TO BE SUPPLIED GALVANIZED (DURAGAL).
- S2. CAST-IN SECTIONS TO BE CUT & WELDED ONSITE (INCLUDING WELDED LUGS) AS PER BUILDER'S PREFERENCE. PROVIDE 6mm THICK END CAPS TO ALL CHS/SHS EXPOSED ENDS, WELDED & THEN GRIND EXPOSED CORNERS & EDGES GROUND TO A ROUNDED FINISH - NO SHARP EDGES. PROVIDE ADDITIONAL GALV. TREATMENT TO ALL CUT/WELDED/SITE DAMAGED STEELWORK & LUGS IN ACCORDANCE WITH GENERAL STEELWORK NOTES (ABOVE). ALTERNATIVLEY; SHOP MITRE/WELD SECTIONS & SHOP WELD LUGS/CLOSING PLATES. HOT DIP GALVANIZE WITH BREATHER HOLES (BE SEALED WITH SIKAFLEX OR EQUIVALENT).
- S3. ALL CAST-IN CHS SECTIONS TO BE SET OUT 8mm FROM EXPOSED CONCRETE EDGES, REFER TO ARCHITECTURAL/CONCEPT DRAWINGS.
- S4. ENSURE ALL LUGS AND REINFORCEMENT CONNECTIONS TO CAST IN STEEL CHS/SHS SECTIONS ARE LOCATED SO AS TO ALLOW A MINIMUM 40mm COVERAGE BELOW CONCRETE SURFACE.

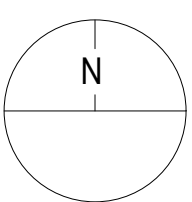
DESIGN BY (SKATEPARK) SKATE SCULPTURE		STRUCTURAL ENGINEER STAMP		ISSUED FOR: A 21.04.2023 PRELIMINARY	SIGNATURE OF AUTHORITY THIS DRAWING IS NOT AUTHORISED FOR TENDER UNLESS SIGNED BY PRIMARY CONTACT HERE  THIS DRAWING IS NOT AUTHORISED FOR CONSTRUCTION UNLESS SIGNED BY PRIMARY CONTACT HERE	PROJECT GREENBUSHES SKATEPARK		SCALE @ A1: NA	GENERAL NOTES	DRAWING NUMBER: GRB-SP-00N	REV A
--	---	---------------------------	---	---	--	----------------------------------	---	-------------------	---------------	-------------------------------	----------

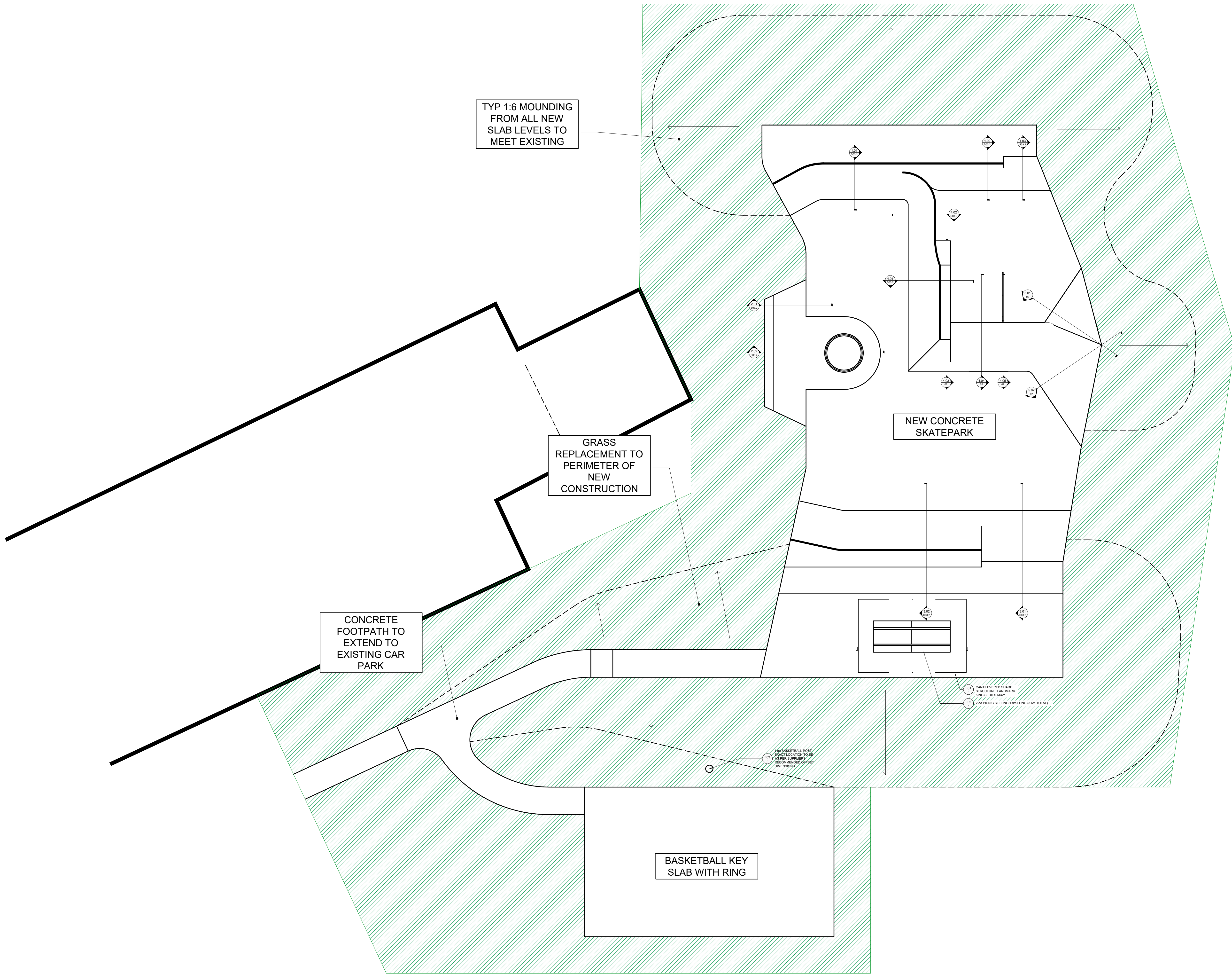

TYP 1:6 MOUNDING FROM ALL NEW SLAB LEVELS TO MEET EXISTING

GRASS REPLACEMENT TO PERIMETER OF NEW CONSTRUCTION

CONCRETE FOOTPATH TO EXISTING CAR PARK

NEW CONCRETE SKATEPARK

BASKETBALL KEY SLAB WITH RING

FR1 CANTILEVERED SHADE STRUCTURE, LANDMARK RING SERIES 834x  
FR2 2 ea PIONIC SETTING 1.8m LONG (3.6m TOTAL)

1 ea BASKETBALL HOOP BRACKET LOCATION TO BE AS PER COMPASS RECOMMENDED OFFSET DRAWING



LEGEND

- [Elevation Tag] ELEVATION TAG RELATIVE TO GEODETIC HEIGHT AS PER SURVEY
- TS TOP OF FINISHED SLAB
- TB TOP OF BANK
- BB BOTTOM OF BANK
- TT TOP OF TRANSITION
- BT BOTTOM OF TRANSITION
- TR TOP OF RAMP (LOW ANGLE)
- BR BOTTOM OF RAMP
- ST TOP OF STEP
- TL TOP OF LEDGE
- TW TOP OF WALL
- BW BOTTOM OF WALL
- RIM RIM OF AREA DRAIN
- INV DRAIN SYSTEM INVERT

SKATEPARK SURFACE

150ø PVC DRAIN PIPE @ 0.5%  
100ø PERF DRAIN PIPE IN GEOFABRIC TO SURROUND TOE OF BOWL AND BEHIND RETAINING WALLS.

Notes

1 Elevations relative to datum shown on site survey / Landscape Plans.

2. Elevation to be confirmed on site during construction startup. 3. Refer to TYPICAL DETAILS for further piping information 4. Max slope on flat slab = 4%

REFER TO ENGINEERING DRAWING FOR AREA DRAIN CONNECTIONS TO DRAINAGE SYSTEM

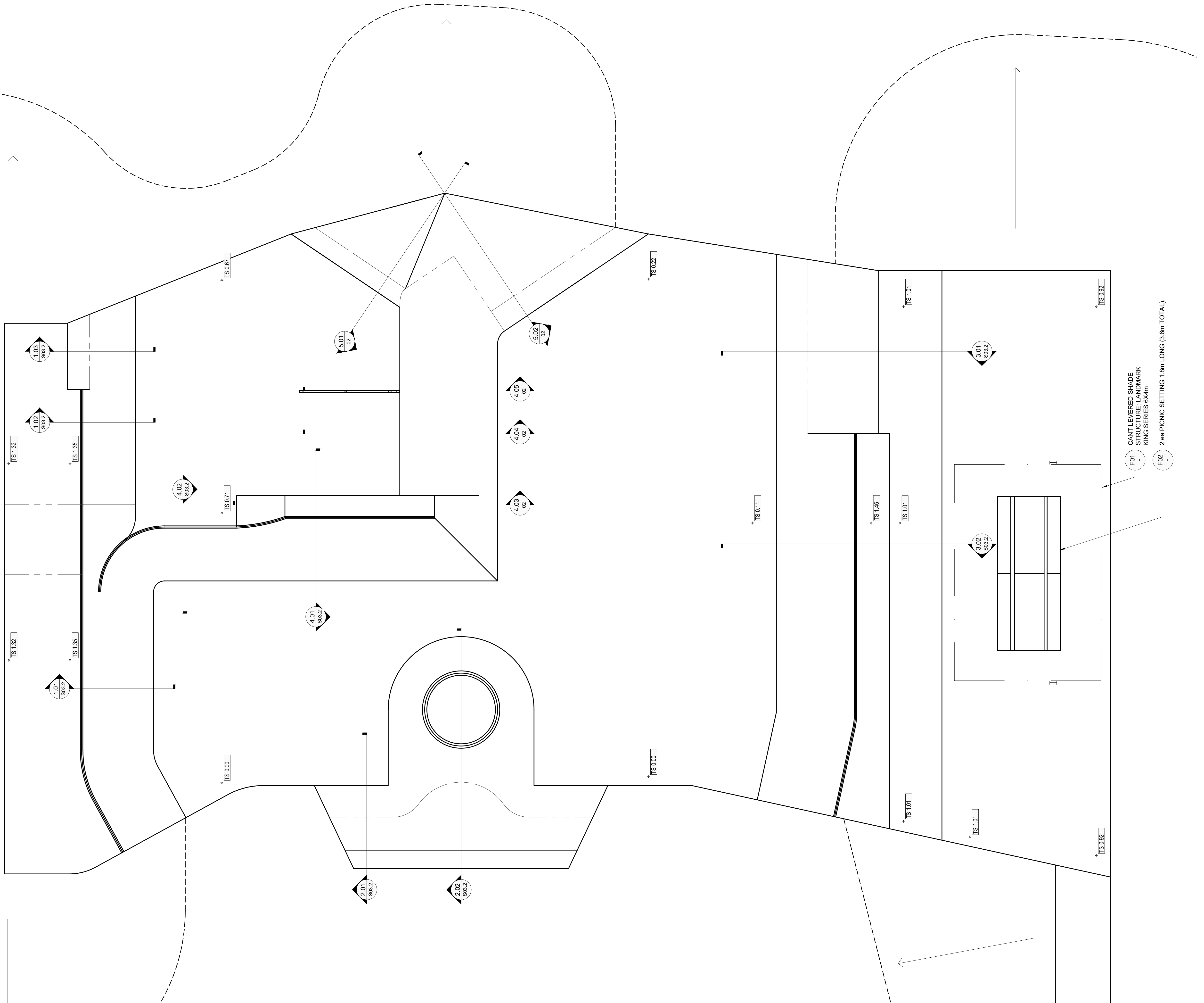

CANTILEVERED SHADE STRUCTURE LANDMARK KING SERIES 6X4m  
F01  
F02  
2 ea PICNIC SETTING 1.8m LONG (3.6m TOTAL).

DESIGN BY (SKATEPARK)  
SKATE SCULPTURE  
0450405510  
ABN: 82 559 152 1 292  
info@skatesculpture.com.au  
1 Howlett St, North Perth WA, 6006



STRUCTURAL ENGINEER STAMP

THE CONCEPTS ON AND CONTENT OF THIS DRAWING REMAIN THE PROPERTY OF SKATE SCULPTURE. THIS DRAWING SHALL ONLY BE USED FOR THE PURPOSE FOR WHICH IT WAS ASSIGNED. UNAUTHORIZED RETENTION, USE OR COPYING OF THIS DOCUMENT OR ITS CONTENTS IS PROHIBITED.  
SKATE SCULPTURE ACCEPTS NO RESPONSIBILITY OR LIABILITY FOR ANY ACTION / CONSEQUENCE FROM THE UNAUTHORIZED USE OR MISUSE OF THIS DRAWING AND ITS CONTENTS OR ANY ALTERATIONS OR AMENDMENTS MADE BY OTHER PARTIES. THIS DRAWING AND ITS CONTENTS SHALL BE DEEMED CONFIDENTIAL UNLESS AGREED WITH SKATE SCULPTURE.



ISSUED FOR:  
A 21.04.2023 PRELIMINARY

SIGNATURE OF AUTHORITY  
THIS DRAWING IS NOT AUTHORISED FOR TENDER UNLESS SIGNED BY PRIMARY CONTACT HERE.  
THIS DRAWING IS NOT AUTHORISED FOR CONSTRUCTION UNLESS SIGNED BY PRIMARY CONTACT HERE.

PROJECT  
GREENBUSHES SKATEPARK  
CLIENT / LGA

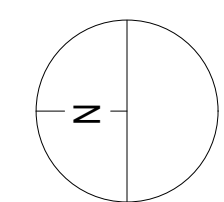

SCALE @ A1:  
1:50  
0 0.5 1 1.5 2 m

GRADING PLAN

DRAWING NUMBER:  
GRB-SP-L03.1

REV  
A

**LEGEND**

ORDINATE SETOUT POINT IN X / Y DIRECTION RELATIVE TO SETOUT POINT #1  
ALL DIMENSIONS IN METERS

ALL INFORMATION AVAILABLE IN CAD FORMAT INCLUDING 3D ELEVATION POINTS FOR DIGITAL SITE SETOUT (TOTAL STATION ETC)

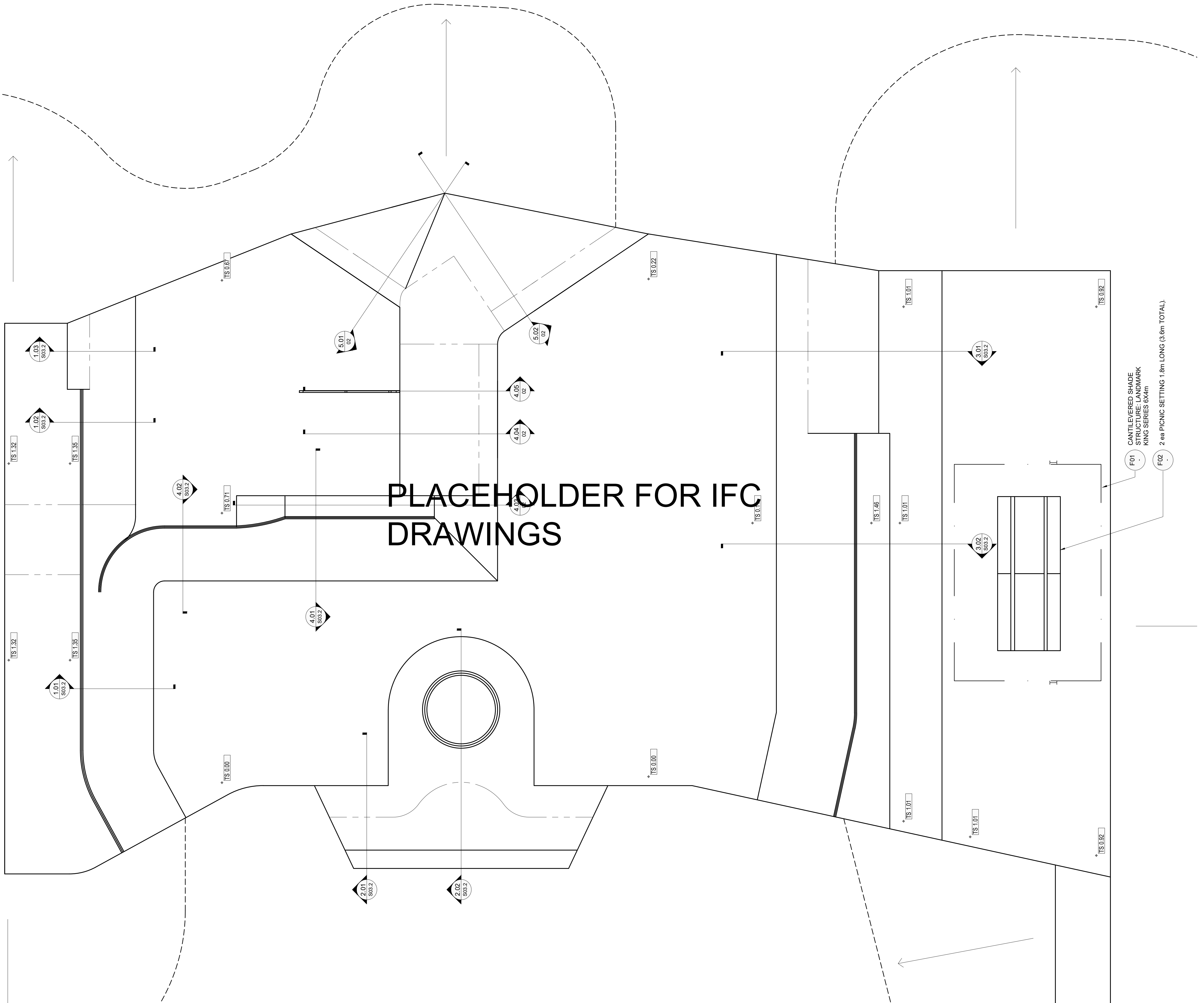
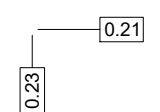

PLACEHOLDER FOR IFC DRAWINGS

CANTILEVERED SHADE STRUCTURE LANDMARK KING SERIES 6x4m  
F01  
F02 2 ea PICNIC SETTING 1.8m LONG (3.6m TOTAL)



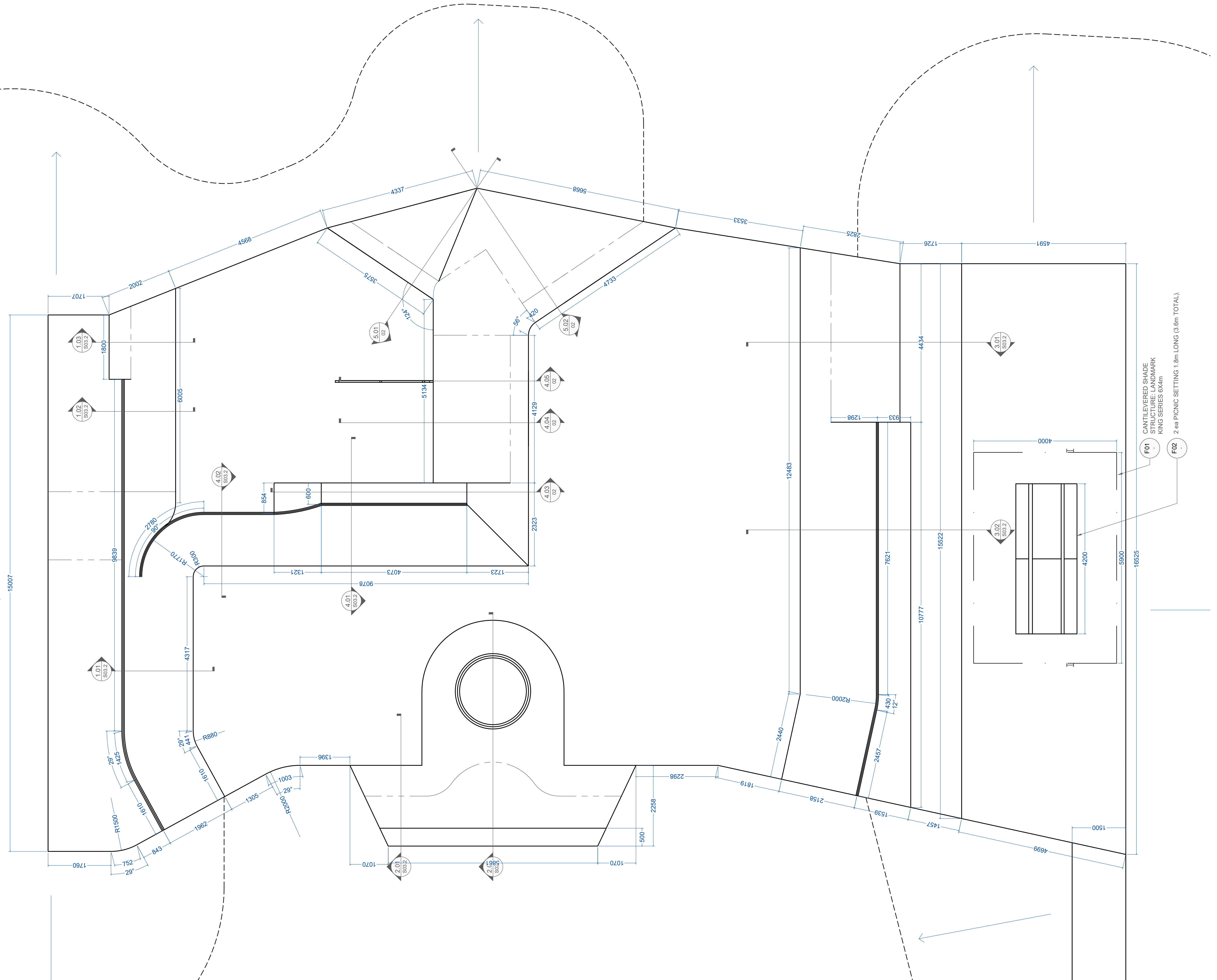

THE CONCEPTS AND CONTENT OF THIS DRAWING REMAIN THE PROPERTY OF SKATE SCULPTURE. THIS DRAWING SHALL ONLY BE USED FOR THE PURPOSE FOR WHICH IT WAS ASSIGNED. UNAUTHORIZED RETENTION, USE OR COPYING OF THIS DOCUMENT OR ITS CONTENTS IS PROHIBITED.  
 SKATE SCULPTURE ACCEPTS NO RESPONSIBILITY OR LIABILITY FOR ANY ACTION OR CONSEQUENCE FROM THE UNAUTHORIZED USE OR MISUSE OF THIS DRAWING AND ITS CONTENTS OR ANY ALTERATIONS OR AMENDMENTS MADE BY OTHER PARTIES. THIS DRAWING AND ITS CONTENTS SHALL BE DEEMED CONFIDENTIAL UNLESS AGREED WITH SKATE SCULPTURE.

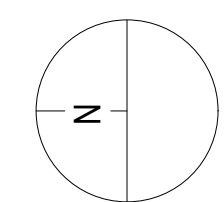

\*PROVIDE SEPARABLE COSTS FOR ADDITION OF COLOUR INTEGRAL COLOUR TO SHOTCRETE AND LEDGES.

ALL CONCRETE / SHOTCRETE TO BE FINISHED WITH 'ASHFORD FORMULA' HARDENER

CONCRETE AND SHOTCRETE FINISHING MUST BE COMPLETED BY QUALIFIED SKATE PARK BUILD CONTRACTOR WITH MINIMUM EXPERIENCE QUALIFICATIONS AS OUTLINED IN TENDER DOCUMENT

**BLEND AREAS**  
 IN MANY INSTANCES THROUGHOUT THE SKATEPARK - ELEVATION, AND DEGREE OF SLOPE BETWEEN BANKS, TRANSITION SLOPES, AND VERTICAL ELEMENTS CAN VARY. WHERE INDICATED ON PLAN PROVIDE CUSTOM CONCRETE BLENDING FOR SMOOTH TRANSITIONS. THESE AREAS TYPICALLY REQUIRE GREATER HAND WORK AND QUALITY CONTROL TO ENSURE THAT BLENDS DO NOT RESULT IN IRREGULAR CONCRETE SURFACE CONDITIONS.

- CONSTRUCTION SEQUENCE:**
- Construction of all concrete elements within the skatepark are best completed in the following order:
    - Footings and walls with footings
    - Bank slab sections, Steps and Transitions
    - Floor Slab
    - Wall, Ledges and Boxes built on slab.
  - Cast in place concrete slab sections shall be constructed in an alternating arrangement so that every other slab section is completed prior to the pouring of the infill slab section. This system provides edge forming for every alternate slab section and helps ensure quality control. **No slab sections shall exceed 4.0m (linear)** in size without control jointing. - see concrete specs.
  - Cold Joints are provided between each slab section. Place tie bars and dowels through all slab sections and floor slab.
  - Expansion Joints: Shall be placed at the base of all vertical concrete elements such as ledges, stairs and walls. Utilize joint compound no greater than 6.25mm in width to help eliminate tripping or irregularities in skating surface.
  - Saw cut pattern is shown to provide direction only. Contractor shall cut slab as needed to prevent cracking. Saw cuts must be made before any signs of thermal cracking. Thermal cracking as a result of insufficient crack control may result in un-skateable surfaces and may need to be replaced.

**CONCRETE NOTES:**  
**CONCRETE APPLICATION**  
 All transition and bank elements to be poured via shotcrete application

**CONCRETE FINISHING**  
 All HORIZONTAL elements to have a power troweled shop floor finish.  
 All TRANSITIONAL elements and features to have a hand trowel shop floor finish.  
 All VERTICAL wall faces to be produced using paper-faced forms.

**CONCRETE PROPERTIES AND REINFORCEMENT**  
 For concrete properties; strength, thickness, reinforcement gauge and spacing, refer to specifications and details

**CONCRETE COLOUR SELECTION**  
 All concrete colours are selected from (REFER TO TENDER SPECIFICATIONS)

Contractor to use selected colours or approved alternative in areas noted on documents.  
 Contractor to follow manufacturer's specifications

**BLEND AREAS:**  
 In many instances throughout the skatepark - elevation, and degree of slope between banks, transition slopes, and vertical elements can vary. Where indicated on plan, provide custom concrete blending for smooth transitions. These areas typically require greater hand work and quality control to ensure that blends do not result in irregular concrete surface conditions.

**COLOUR SCHEDULE**

	CONCRETE FLAT SLAB COLOUR CCS. CANVAS
	BANK / TRANSITION COLOUR: COLOUR: SYNERGY LIGHT BROWN
	BANK / TRANSITION COLOUR: COLOUR: SYNERGY LIGHT BROWN OR ALTERNATIVE OPTIONAL: PAPYRUS (TBC)
	BASKETBALL COURT SLAB NATURAL GREY, BROOM FINISHED WITH PAINTED SURFACE
	CONCRETE FOOTPATH NATURAL GREY BROOM FINISH

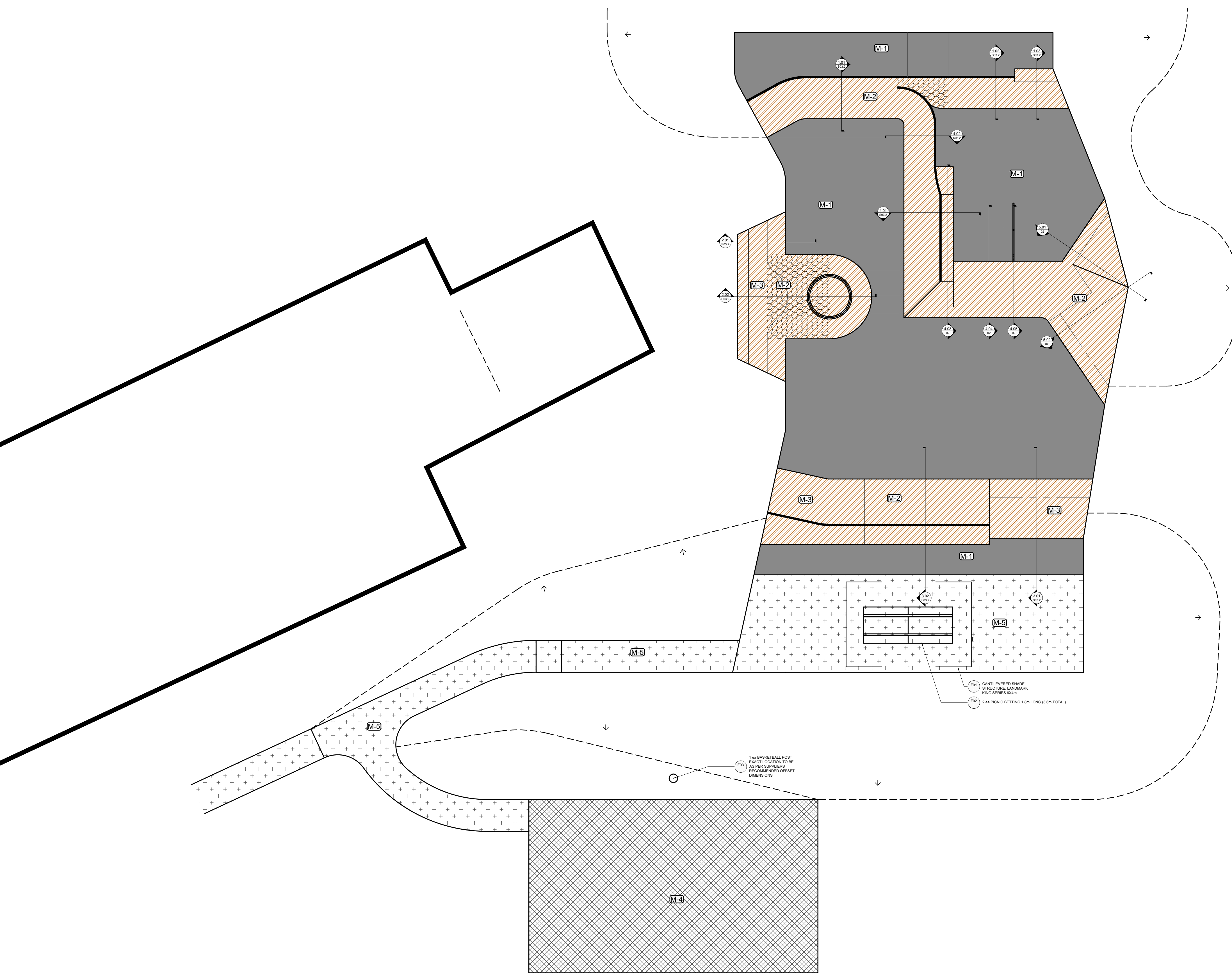



- CONSTRUCTION SEQUENCE:**
- Construction of all concrete elements within the skatepark are best completed in the following order:
    - Footings and walls with footings
    - Bank slab sections, Steps and Transitions
    - Floor Slab
    - Wall, Ledges and Boxes built on slab.
  - Cast in place concrete slab sections shall be constructed in an alternating arrangement so that every other slab section is completed prior to the pouring of the infill slab section. This system provides edge forming for every alternate slab section and helps ensure quality control. **No slab sections shall exceed 4.0m (linear)** in size without control jointing. - see concrete specs.
  - Cold Joints are provided between each slab section. Place tie bars and dowels through all slab sections and floor slab.
  - Expansion Joints: Shall be placed at the base of all vertical concrete elements such as ledges, stairs and walls. Utilize joint compound no greater than 6.25mm in width to help eliminate tripping or irregularities in skating surface.
  - Saw cut pattern is shown to provide direction only. Contractor shall cut slab as needed to prevent cracking. Saw cuts must be made before any signs of thermal cracking. Thermal cracking as a result of insufficient crack control may result in un-skateable surfaces and may need to be replaced.

**CONCRETE NOTES:**  
**CONCRETE APPLICATION**  
 All transition and bank elements to be poured via shotcrete application

**CONCRETE FINISHING**  
 All HORIZONTAL elements to have a power troweled shop floor finish.  
 All TRANSITIONAL elements and features to have a hand trowel shop floor finish.  
 All VERTICAL wall faces to be produced using paper-faced forms.

**CONCRETE PROPERTIES AND REINFORCEMENT**  
 For concrete properties; strength, thickness, reinforcement gauge and spacing, refer to specifications and details

**CONCRETE COLOUR SELECTION**  
 All concrete colours are selected from (REFER TO TENDER SPECIFICATIONS)

Contractor to use selected colours or approved alternative in areas noted on documents.  
 Contractor to follow manufacturer's specifications

**BLEND AREAS:**  
 In many instances throughout the skatepark - elevation, and degree of slope between banks, transition slopes, and vertical elements can vary. Where indicated on plan, provide custom concrete blending for smooth transitions. These areas typically require greater hand work and quality control to ensure that blends do not result in irregular concrete surface conditions.

**LEGEND**

SJ	SAW CUT	
EJV	EXPANSION JOINT	
CJ	COLD JOINT	
PJ	PROPOSED SLAB SECTION POUR / FORM LOCATION	

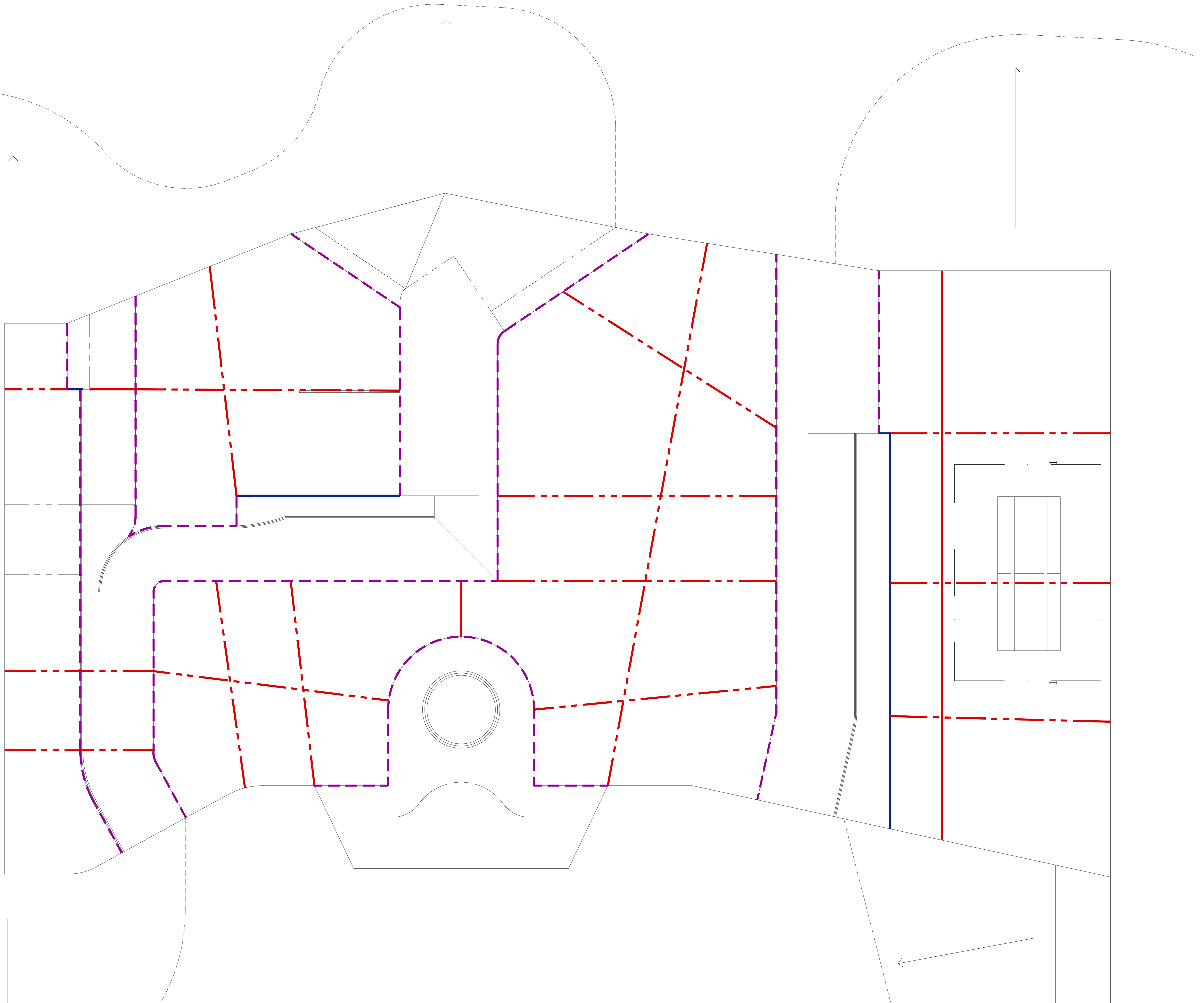

STRUCTURAL ENGINEER STAMP

THE CONCEPTS ON AND CONTENT OF THIS DRAWING REMAIN THE PROPERTY OF SKATE SCULPTURE. THIS DRAWING SHALL ONLY BE USED FOR THE PURPOSE FOR WHICH IT WAS SUBMITTED. UNAUTHORIZED RETENTION, USE OR COPYING OF THIS DOCUMENT OR ITS CONTENTS IS PROHIBITED.  
 SKATE SCULPTURE ACCEPTS NO RESPONSIBILITY OR LIABILITY FOR ANY ACTION / CONSEQUENCE FROM THE UNAUTHORIZED USE OR MISUSE OF THIS DRAWING AND ITS CONTENTS OR ANY ALTERATIONS OR AMENDMENTS MADE BY OTHER PARTIES. THIS DRAWING AND ITS CONTENTS SHALL BE DEEMED CONFIDENTIAL UNLESS AGREED WITH SKATE SCULPTURE.



ISSUED FOR:  
 A 21.04.2023 PRELIMINARY

SIGNATURE OF AUTHORITY  
 THIS DRAWING IS NOT AUTHORIZED FOR TENDER UNLESS SIGNED BY PRIMARY CONTACT HERE  
 \_\_\_\_\_  
 THIS DRAWING IS NOT AUTHORIZED FOR CONSTRUCTION UNLESS SIGNED BY PRIMARY CONTACT HERE  
 \_\_\_\_\_

PROJECT  
 GREENBUSHES SKATEPARK  
 CLIENT / LGA

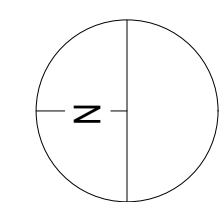

SCALE @ A1:  
 1:50

**JOINT PLAN**  
 DRAWING NUMBER:  
 GRB-SP-L07.1  
 REV  
 A

**STEEL COPING NOTES :** REFER TO PROJECT SPECIFIC DETAILS TO CONFIRM HANDRAIL DIMENSIONS.  
 ALL STEEL GRINDING EDGES AND STEEL COPING SHALL BE: DURAGAL OR EQUAL APPROVED  
 ALL METAL WORK SHALL STRICTLY ADHERE TO THE SPECIFIED WALL THICKNESS. ALL METAL WORK SHALL BE GROUND IN SHOP AND JOINED PIECES HOT DIP GALVANIZED PRIOR TO DELIVERY TO SITE. NO MILL SCALE ON METAL SHALL BE TOLERATED. ALL SITE WELDING SHALL BE PRIMED, RETOUCHEDED AND PAINTED WITH A ZINC RICH SILVER GALVANIZING PAINT (J.N.O) PRIOR TO COMPLETION.

- RSP: NB50 X 4.5 CHS. RM  
D03
- CPX: CP: NB50 X 4.5 CHS. CPX  
D01
- SST: 50mm x 50mm x 4mm SQUARE HSS SST  
D03
- FB50: 50mm x 6mm FLAT STEEL BAR FSB  
D03
- RHS: 150X50X5 RHS 'DURAGAL' TO PERIMETER OF FLOATING CONCRETE LEDGE RHS  
D03
- PFC: PFC CHANEL COPING PFC  
D03
- POOL: POOL BLOCK COPING TILE. SEE CONCRETE SURFACES PLAN PLAN POOL  
D03
- NO: "NOPING" CONCRETE EDGE ONLY. R60 ROUND FILLET

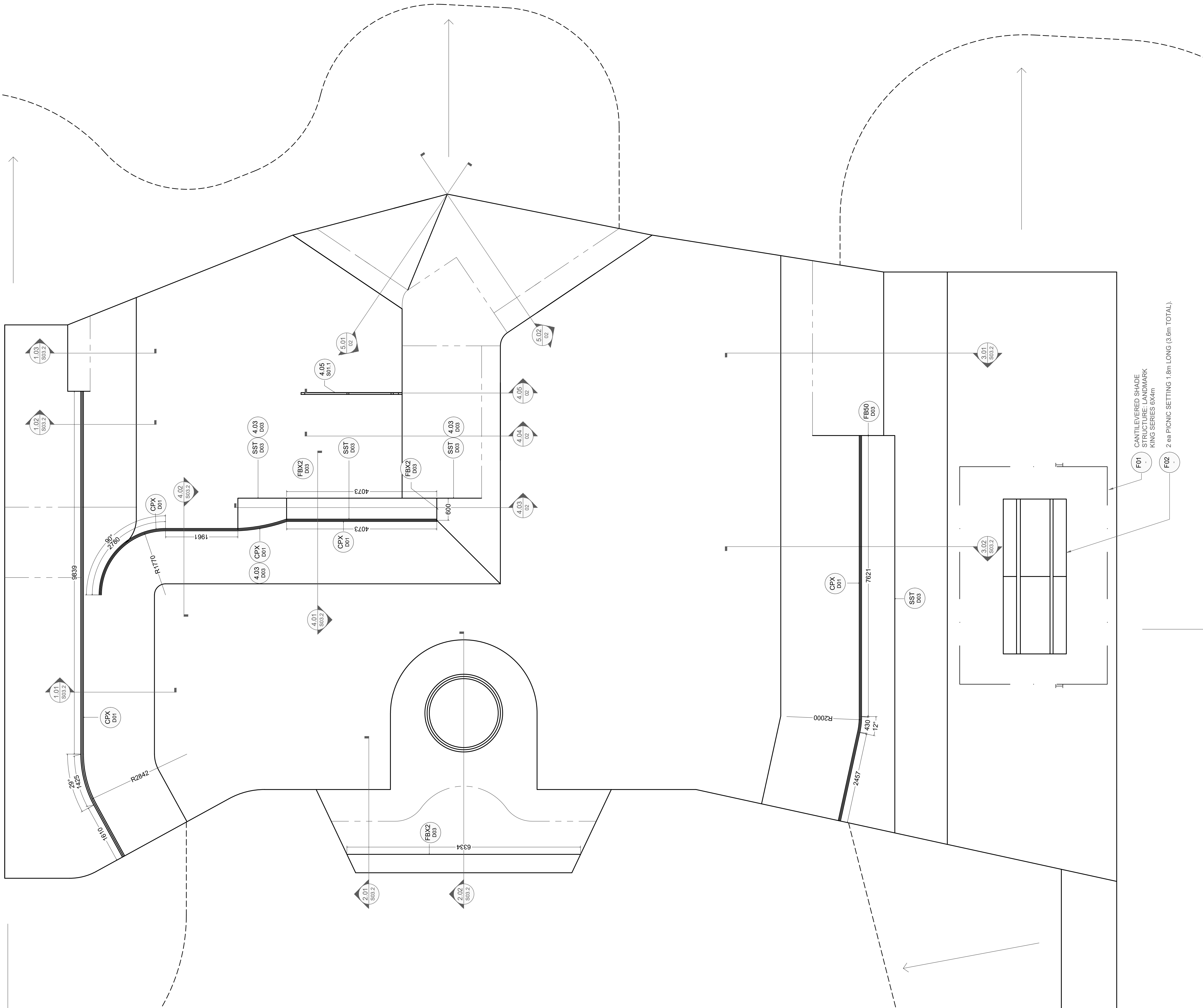

F01 CANTILEVERED SHADE STRUCTURE: LANDMARK KING SERIES 6X4m  
 F02 2 ea PICNIC SETTING 1.8m LONG (3.6m TOTAL)

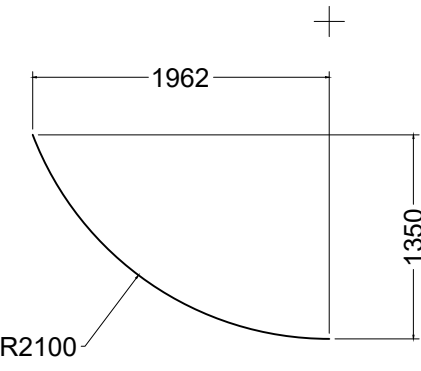

1.01 TRANSITION  
S01.1 R:2100 H:1350

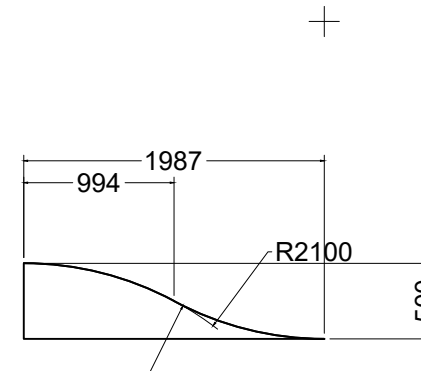

2.02 ROLL IN  
S01.1 R:2100 H:500 R(TOP): 2100

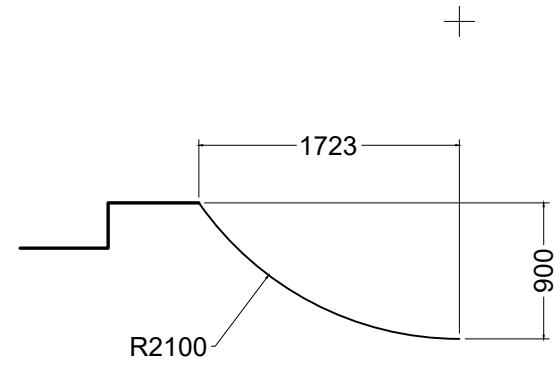

4.01 TRANSITION  
S01.1 R:2100 H:900

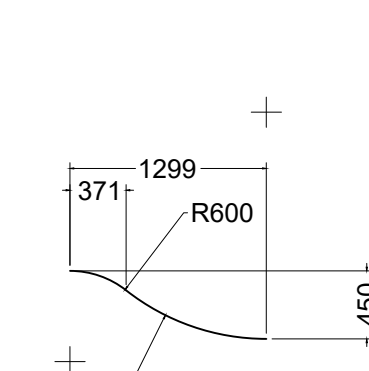

1.03 ROLL IN  
S01.1 R:1500 H:450 R(TOP): 600

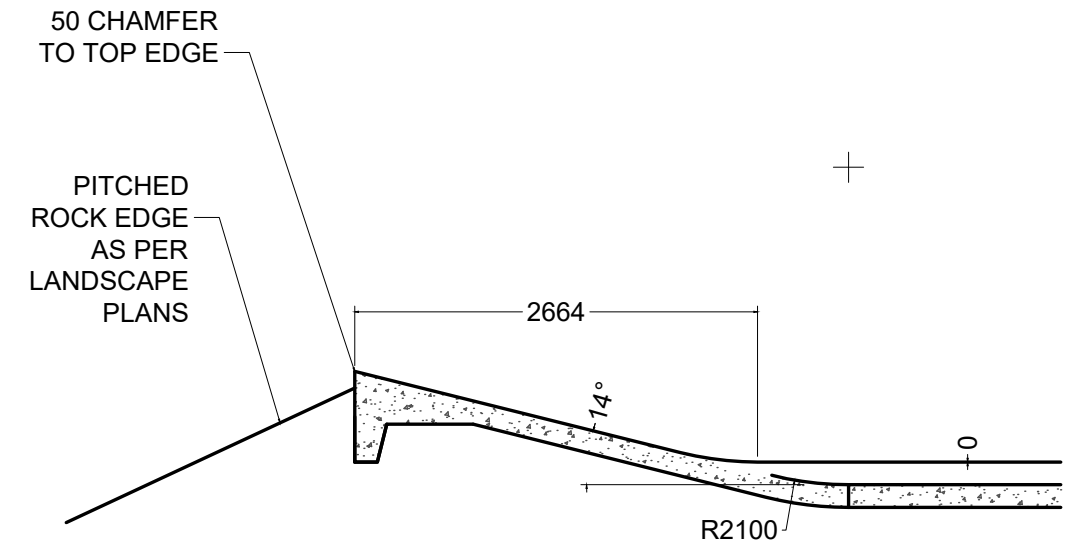

TBET TD02 TYPICAL BANK WITH EDGE THICKENING

5.01 HIP - TOP FACE  
S01.1 CUSTOM

1:50

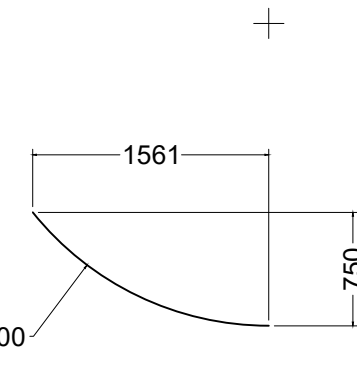

1.01 TRANSITION  
S01.1 R:2000 H:750

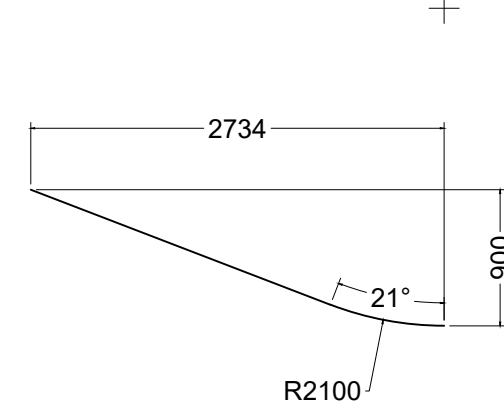

3.01 BANK  
S01.1 21° H:900 R:2100

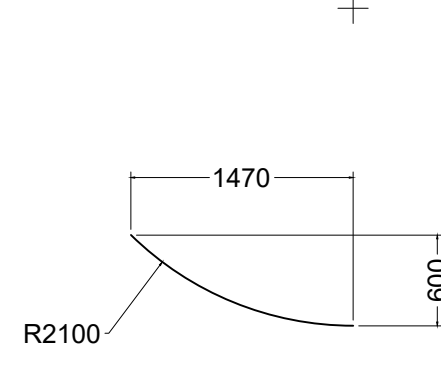

4.02 TRANSITION  
S01.1 R:2100 H:600

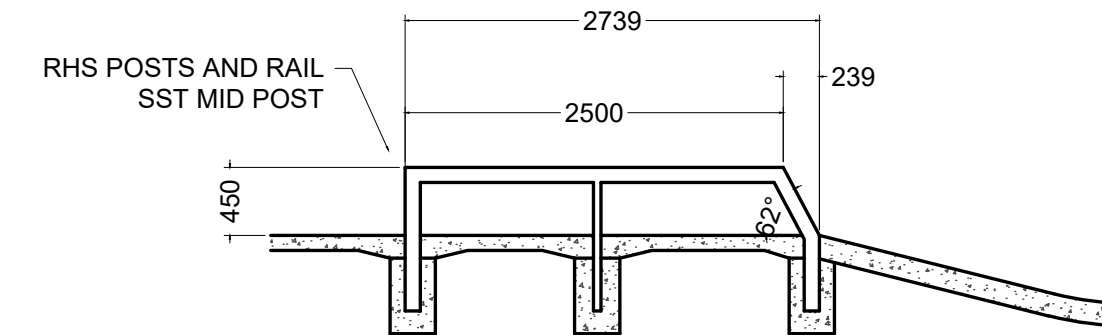

RM TD03 100x50 RHS RAIL WITH 50x50 POSTS AND FOOTINGS AS PER

4.05 RAIL  
S01.1 CUSTOM

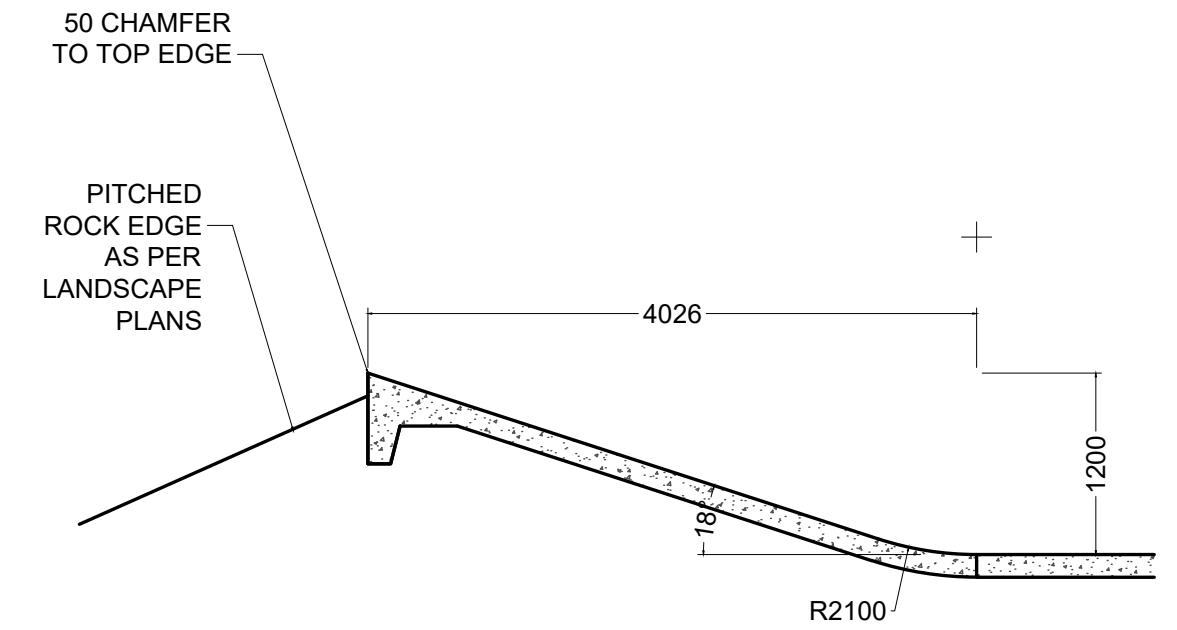

TBET TD02 TYPICAL BANK WITH EDGE THICKENING

5.02 HIP LOWER FACE  
S01.1 CUSTOM

1:50

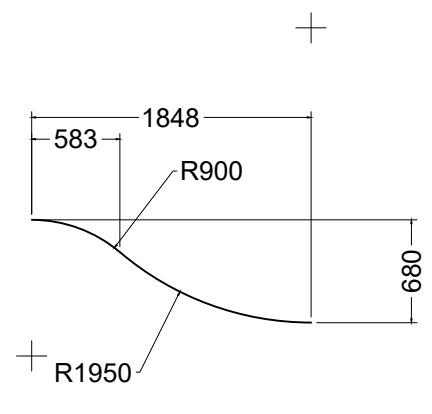

1.03 ROLL IN  
S01.1 R:1950 H:680 R(TOP): 900

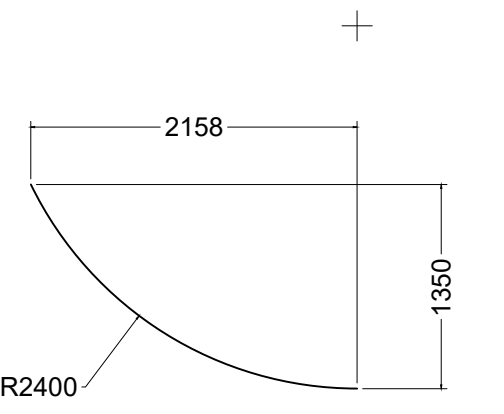

3.02 TRANSITION  
S01.1 R:2400 H:1350

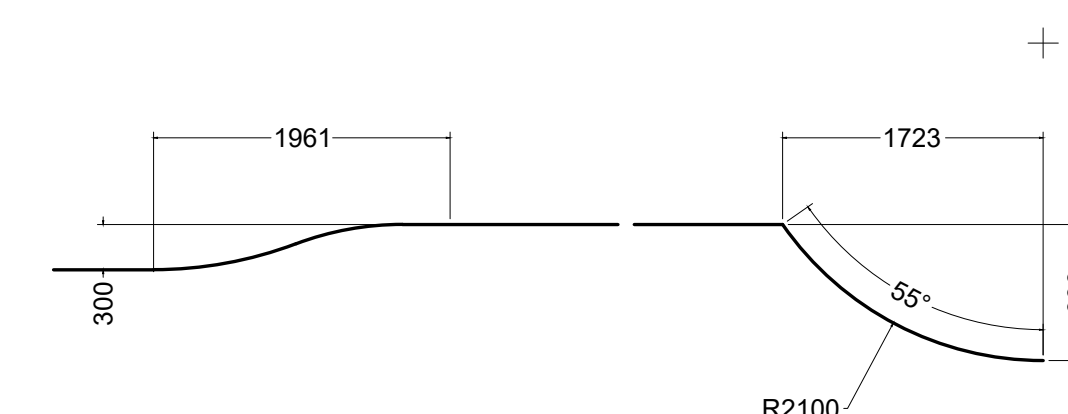

4.03 OP TO BANK EXTENSION  
S01.1 CUSTOM

1:50

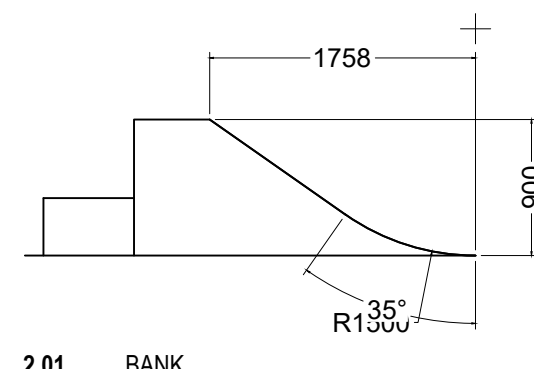

2.01 BANK  
S01.1 35° H:900 R:1350

1:50

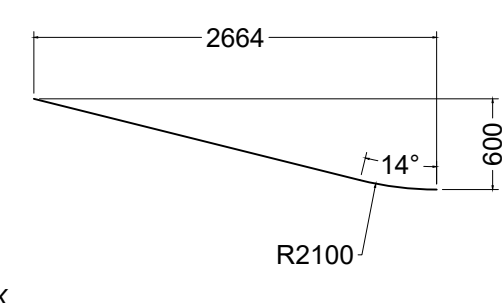

4.04 BANK  
S01.1 14° H:600 R:2100

1:50

DESIGN BY (SKATEPARK)

SKATE SCULPTURE



045040510  
ABN: 82 292 1521 292  
info@skatesculpture.com.au  
1 Howlett St, North Perth WA, 6006

STRUCTURAL ENGINEER STAMP

THE CONCEPTS ON AND CONTENT OF THIS DRAWING REMAIN THE PROPERTY OF SKATE SCULPTURE. THIS DRAWING SHALL ONLY BE USED FOR THE PURPOSE FOR WHICH IT WAS SUBMITTED. UNAUTHORIZED RETENTION, USE OR COPYING OF THIS DOCUMENT OR ITS CONTENTS IS PROHIBITED.  
SKATE SCULPTURE ACCEPTS NO RESPONSIBILITY OR LIABILITY FOR ANY ACTION / CONSEQUENCE FROM THE UNAUTHORIZED USE OR MISUSE OF THIS DRAWING AND ITS CONTENTS OR ANY ALTERATIONS OR AMENDMENTS MADE BY OTHER PARTIES. THIS DRAWING AND ITS CONTENTS SHALL BE DEEMED CONFIDENTIAL UNLESS AGREED WITH SKATE SCULPTURE.



ISSUED FOR:

A 21.04.2023 PRELIMINARY

SIGNATURE OF AUTHORITY

THIS DRAWING IS NOT AUTHORIZED FOR TENDER UNLESS SIGNED BY PRIMARY CONTACT HERE.

THIS DRAWING IS NOT AUTHORIZED FOR CONSTRUCTION UNLESS SIGNED BY PRIMARY CONTACT HERE.

PROJECT  
GREENBUSHES SKATEPARK

CLIENT / LGA

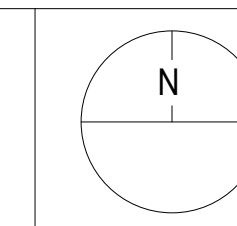

SCALE @ A1:  
1:50

SECTIONS

DRAWING NUMBER:  
GRB-SP-S01.1

REV  
A



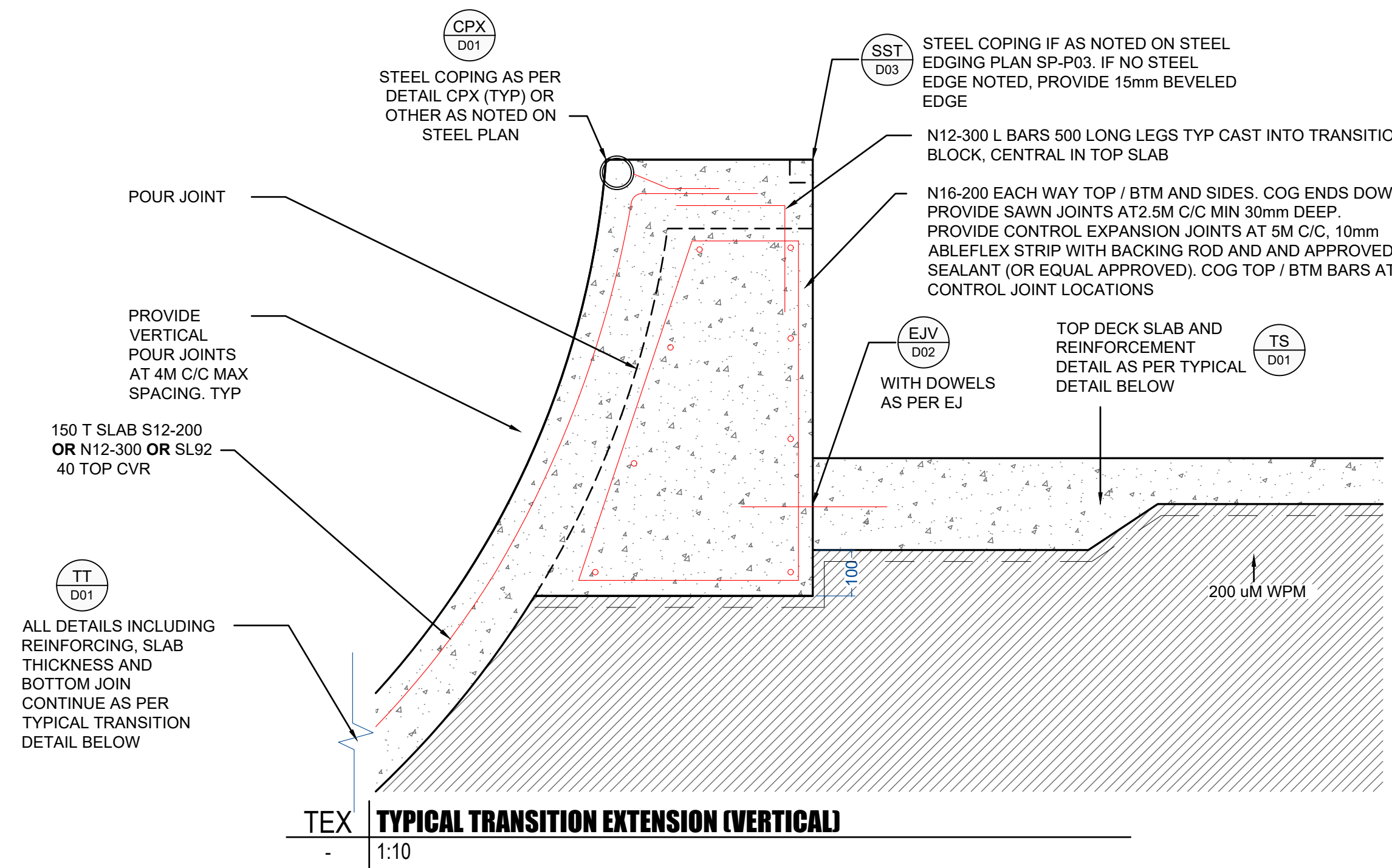

TEX | **TYPICAL TRANSITION EXTENSION (VERTICAL)**  
1:10

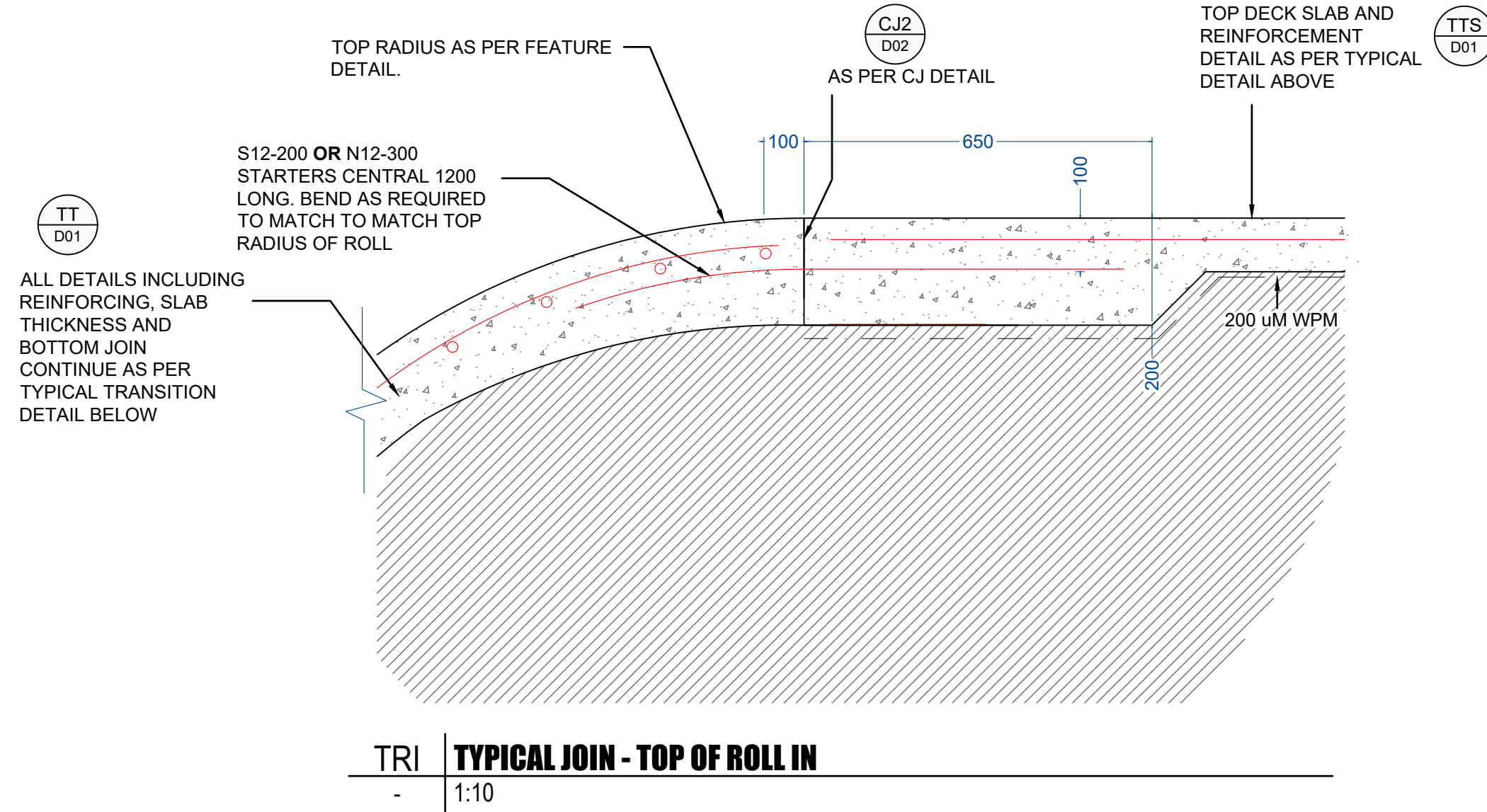

TRI | **TYPICAL JOIN - TOP OF ROLL IN**  
1:10

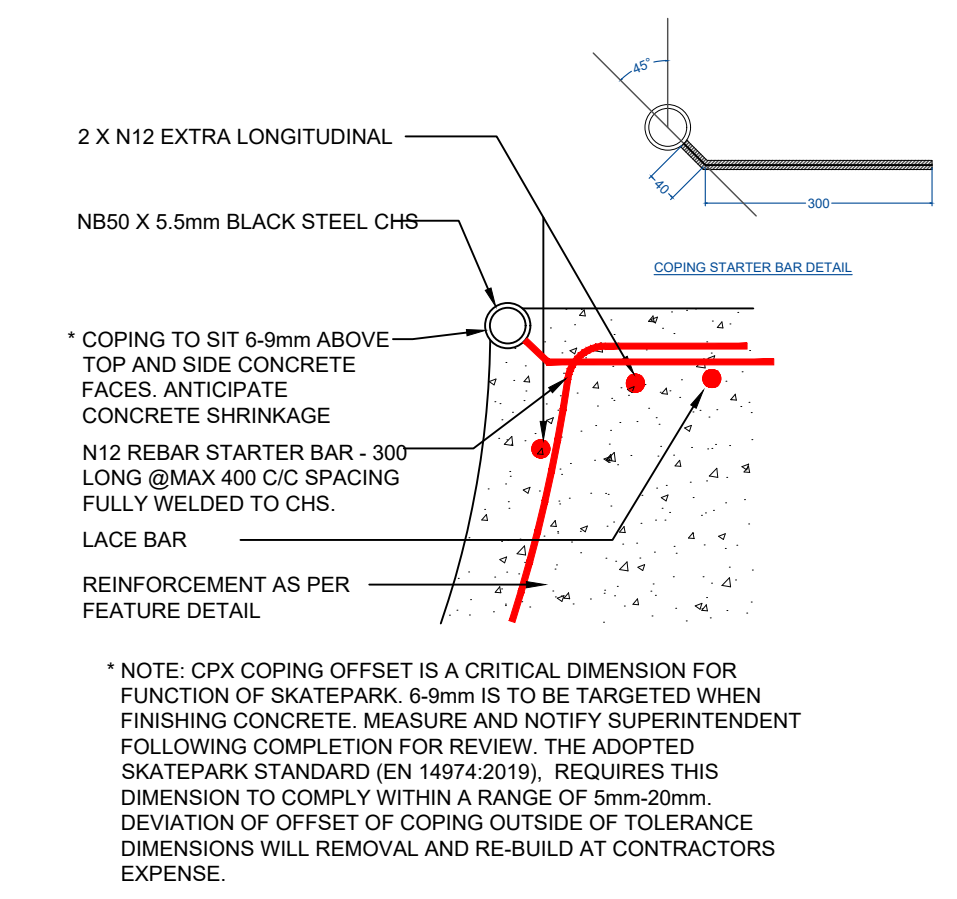

CPX | **CHS COPING**  
1:10

- TYPICAL CONSTRUCTION SEQUENCE: TRANSITIONS
1. CONSTRUCT SLOPE STABILIZATION SLAB WITH EXPOSED REBAR BENDS PROTRUDING WILD
  2. PREPARE SUB GRADE MATERIAL
  3. CUT EXPOSED REBAR BENDS TO CORRECT ELEVATION AND SECURE COPING WITH STITCH WELDS
  4. FIX 6.35 STEEL BACKING PLATE TO 50mm PIPE AS PER DETAIL BLOW UP: CP (IF APPLICABLE)
  5. SECURE HOOK BARS WITH 6mm FILLET WELD ALL AROUND
  6. CONSTRUCT REBAR MAT TO SLABS AND TRANSITION
  7. CONSTRUCT TRANSITION SLAB SECTION
  8. ENSURE TOE OF BANK FINISHES AT TANGENT TO ADJACENT SLAB WITH NO POOLING / PUDDLES.
  9. CONSTRUCT TOP DECK AND FLAT BOTTOM GRADING AWAY FROM TRANSITION TO PREVENT PUDDLES

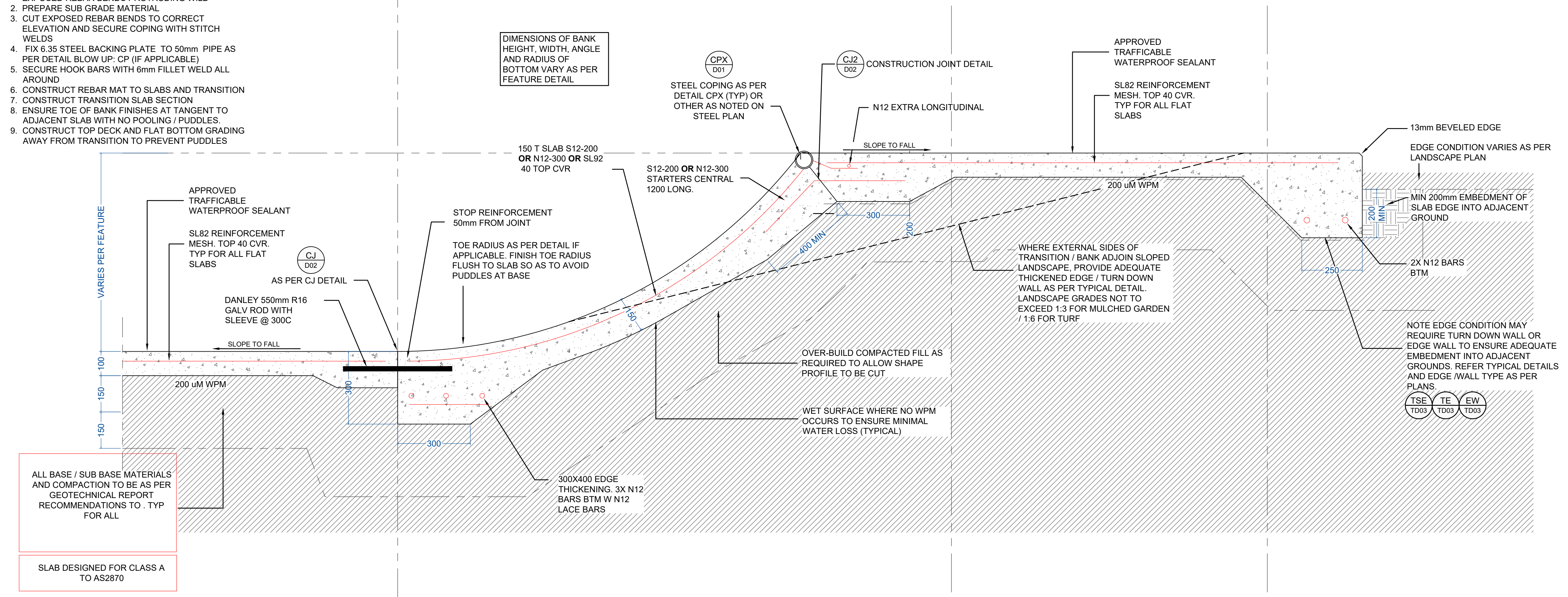

TS | **TYPICAL FLAT SLAB DETAIL**  
1:10

TT | **TYPICAL TRANSITION DETAIL**  
1:10

TTS | **TYPICAL TOP DECK DETAIL**  
1:10

TSE | **TYPICAL SLAB EDGE DETAIL**  
1:10

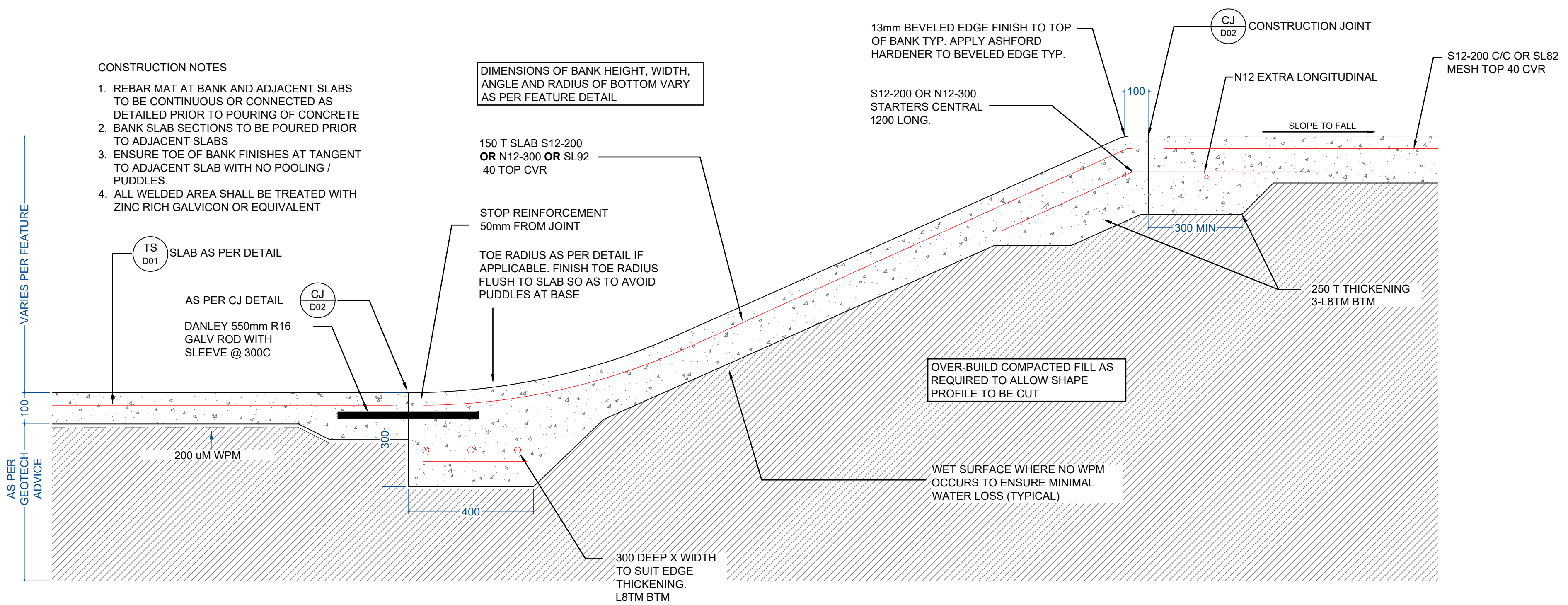

- CONSTRUCTION NOTES**
1. REBAR MAT AT BANK AND ADJACENT SLABS TO BE CONTINUOUS OR CONNECTED AS DETAILED PRIOR TO POURING OF CONCRETE
  2. BANK SLAB SECTIONS TO BE POURED PRIOR TO ADJACENT SLABS
  3. ENSURE TOE OF BANK FINISHES AT TANGENT TO ADJACENT SLAB WITH NO POOLING / PUDDLES.
  4. ALL WELDED AREA SHALL BE TREATED WITH ZINC RICH GALVICON OR EQUIVALENT

**DIMENSIONS OF BANK HEIGHT, WIDTH, ANGLE AND RADIUS OF BOTTOM VARY AS PER FEATURE DETAIL**

**TB TYPICAL BANK DETAIL**  
1:10

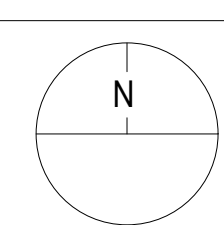



**NOTES:**

- CONSTRUCTION OF ALL CONCRETE ELEMENTS WITHIN THE SKATEPARK ARE BEST COMPLETED IN THE FOLLOWING ORDER:
  - FOOTINGS AND WALLS WITH FOOTINGS
  - BANK SLAB SECTIONS, STEPS AND TRANSITIONS
  - FLOOR SLAB
  - WALL, LEDGES AND BOXES BUILT ON SLAB.
- CAST IN PLACE CONCRETE SLAB SECTIONS SHALL BE CONSTRUCTED IN AN ALTERNATING ARRANGEMENT SO THAT EVERY OTHER SLAB SECTION IS COMPLETED PRIOR TO THE POURING OF THE INFILL SLAB SECTION. THIS SYSTEM PROVIDES EDGE FORMING FOR EVERY ALTERNATE SLAB SECTION AND HELPS ENSURE QUALITY CONTROL. NO SLAB SECTIONS SHALL EXCEED 4.0M (LINEAR) IN SIZE WITHOUT CONTROL JOINTING. -SEE CONCRETE SPECS.
- COLD JOINTS ARE PROVIDED BETWEEN EACH SLAB SECTION. PLACE THE BARS AND DOWELS OR CONTINUOUS REBAR (ROUND DEFORMED REINFORCING STEEL) THROUGH ALL SLAB SECTIONS AND FLOOR SLAB.
- EXPANSION JOINTS: SHALL BE PLACED AT THE BASE OF ALL VERTICAL CONCRETE ELEMENTS SUCH AS LEDGES, STAIRS AND WALLS. UTILIZE JOINT COMPOUND NO GREATER THAN 6.25MM IN WIDTH TO HELP ELIMINATE TRIPPING OR IRREGULARITIES IN SKATING SURFACE.
- SAW CUT PATTERN IS SHOWN TO PROVIDE DIRECTION. CONTRACTOR SHALL CUT SLAB AS NEEDED TO PREVENT CRACKING. SAW CUTS MUST BE MADE BEFORE ANY SIGNS OF THERMAL CRACKING. THERMAL CRACKING AS A RESULT OF INSUFFICIENT CRACK CONTROL MAY RESULT IN UN-SKATEABLE SURFACES AND MAY NEED TO BE REPLACED.

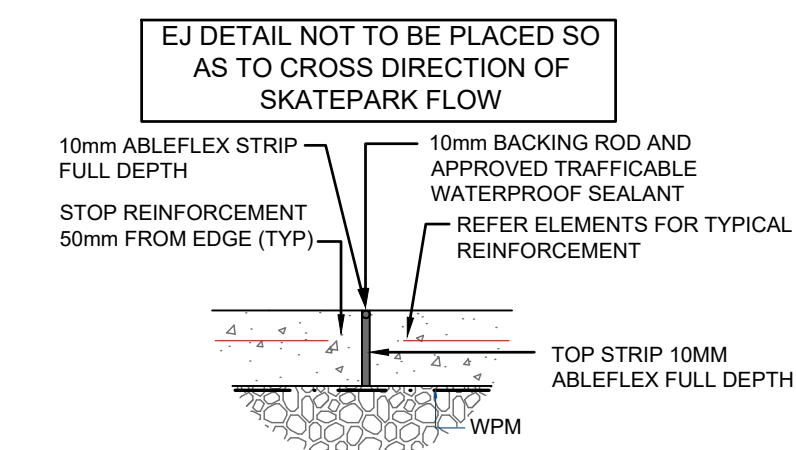
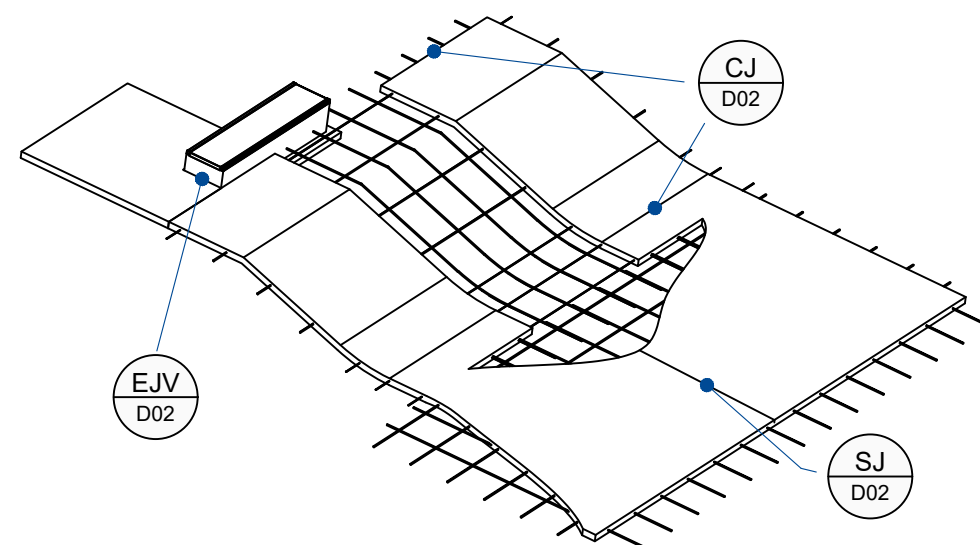

**EJ TYPICAL EXPANSION JOINT DETAIL**  
1:10

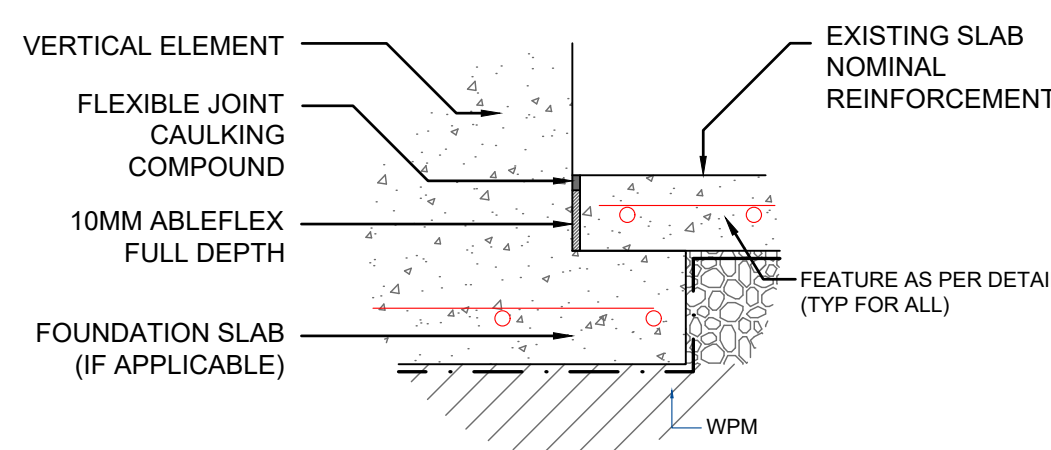

**EJV TYPICAL EXPANSION JOINT AT VERTICAL**  
1:10

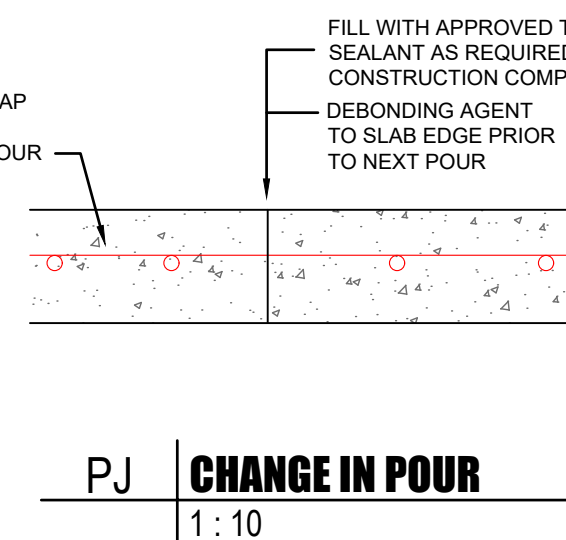

**PJ CHANGE IN POUR**  
1:10

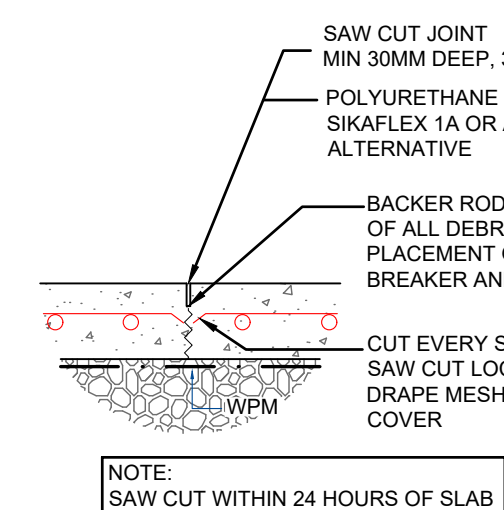

**SJ TYPICAL SAW CUT**  
1:10

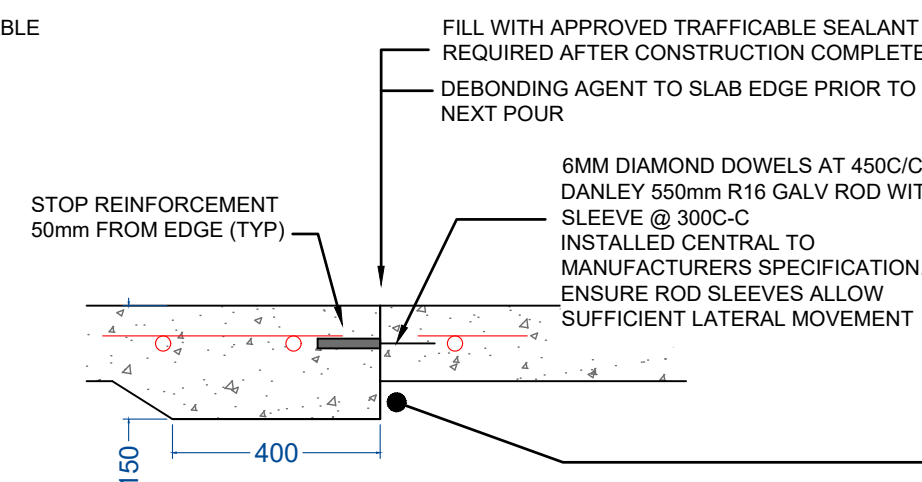

**CJ TYPICAL COLD JOINT**  
1:10

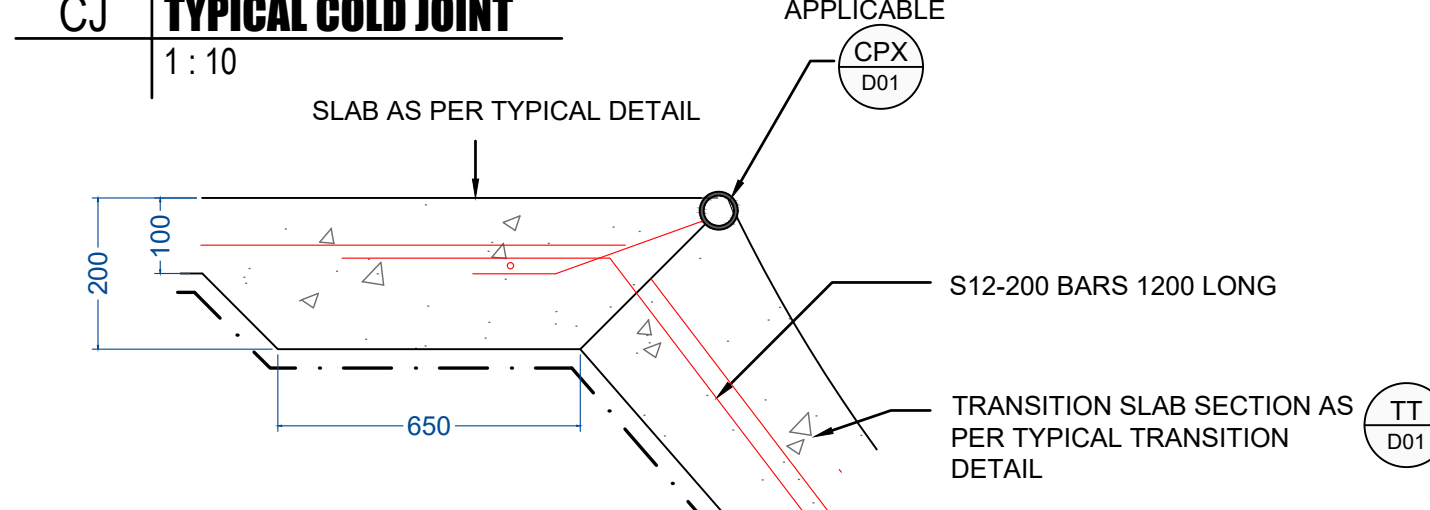

**CJ2 TYPICAL COLD JOINT (TOP OF TRANSITION)**  
1:10

TYPICAL COLD JOINT AS SHOWN TO BE LOCATED IN THE FOLLOWING INSTANCES:  
 -BANK TOE TO FLAT SLAB  
 -TRANSITION TOE TO FLAT SLAB  
 -TRANSITION TOP TO FLAT SLAB WHERE NO STEEL COPING INCLUDED  
 -FLAT SLAB TO FLAT SLAB  
 THICKENED SLAB IS NOT REQUIRED BETWEEN ALTERNATING SLAB SECTION POURS FOR BANKS AND TRANSITIONS AS OUTLINED IN CONSTRUCTION SEQUENCE NOTES ON CONCRETE AND JOINT PLAN

**STEEL COPING NOTES :** REFER TO PROJECT SPECIFIC DETAILS TO CONFIRM HANDRAIL DIMENSIONS.  
 ALL STEEL GRINDING EDGES AND STEEL COPING SHALL BE: DURAGAL OR EQUAL APPROVED  
 ALL METAL WORK SHALL STRICTLY ADHERE TO THE SPECIFIED WALL THICKNESS. ALL METAL WORK SHALL BE GROUND IN SHOP AND JOINED PIECES HOT DIP GALVANIZED PRIOR TO DELIVERY TO SITE. NO MILL SCALE ON METAL SHALL BE TOLERATED. ALL SITE WELDING SHALL BE PRIMED, RETOUCHE AND PAINTED WITH A ZINC RICH SILVER GALVANIZING PAINT (U.N.O) PRIOR TO COMPLETION.

- RSP: NB50 X 4.5 CHS. (RM D03)
- CPX: CP- NB50 X 4.5 CHS. (CPX D01)
- SST: 50mm x 50mm x 4mm SQUARE HSS (SST D03)
- FSB: 50mm x 6mm FLAT STEEL BAR (FSB D03)
- RHS: 150X50X5 RHS 'DURAGAL' TO PERIMETER OF FLOATING CONCRETE LEDGE (RHS D03)
- PFC: PFC CHANEL COPING (PFC D03)
- POOL: POOL BLOCK COPING TILE. SEE CONCRETE SURFACES PLAN PLAN (POOL D03)
- NO: "NOPING" CONCRETE EDGE ONLY. R60 ROUND FILLET

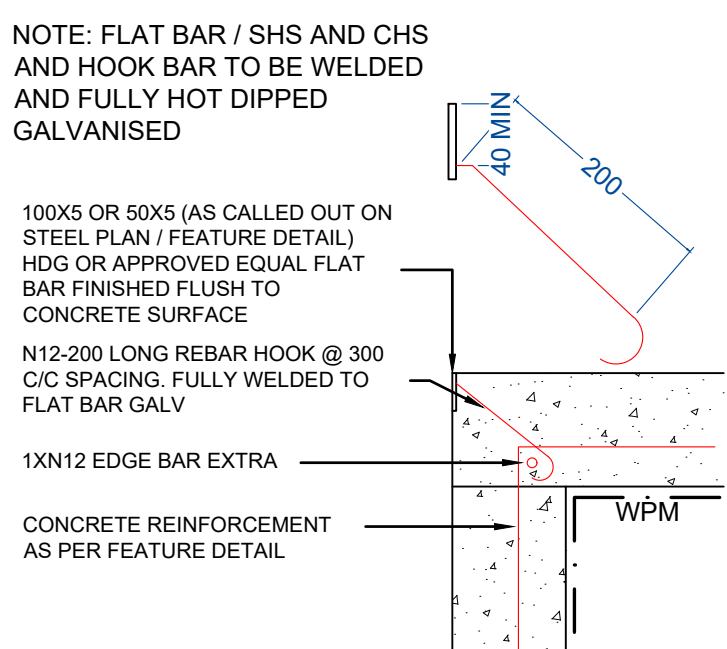

**FSB FLAT STEEL BAR COPING**  
1:10

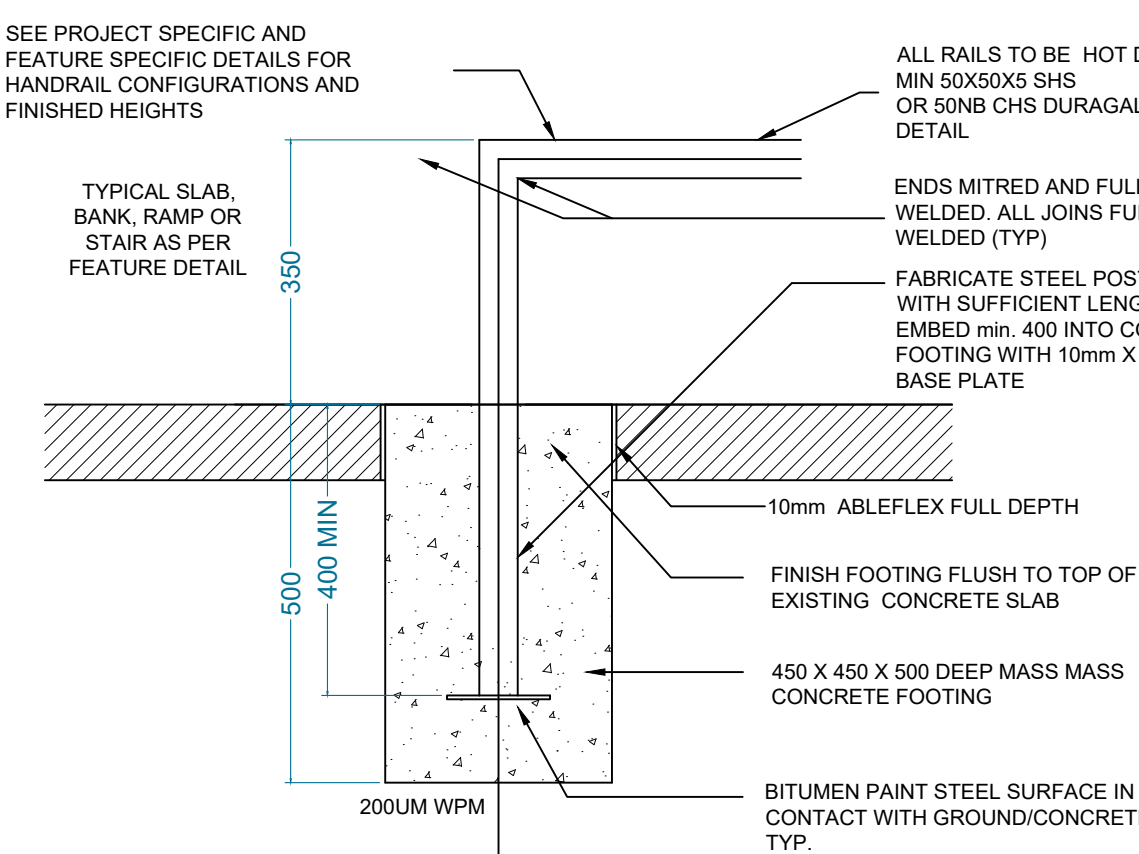

**RM TYPICAL RAIL MOUNTING DETAIL**  
1:10

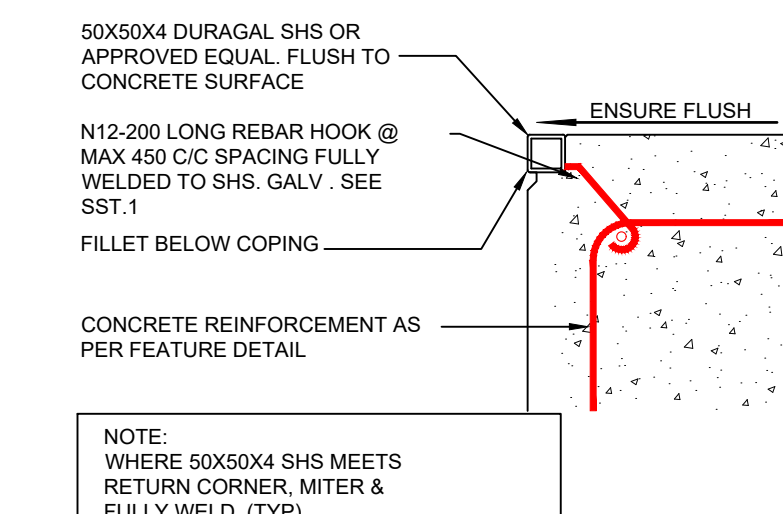

**SST SQUARE STEEL TUBE COPING**  
1:10

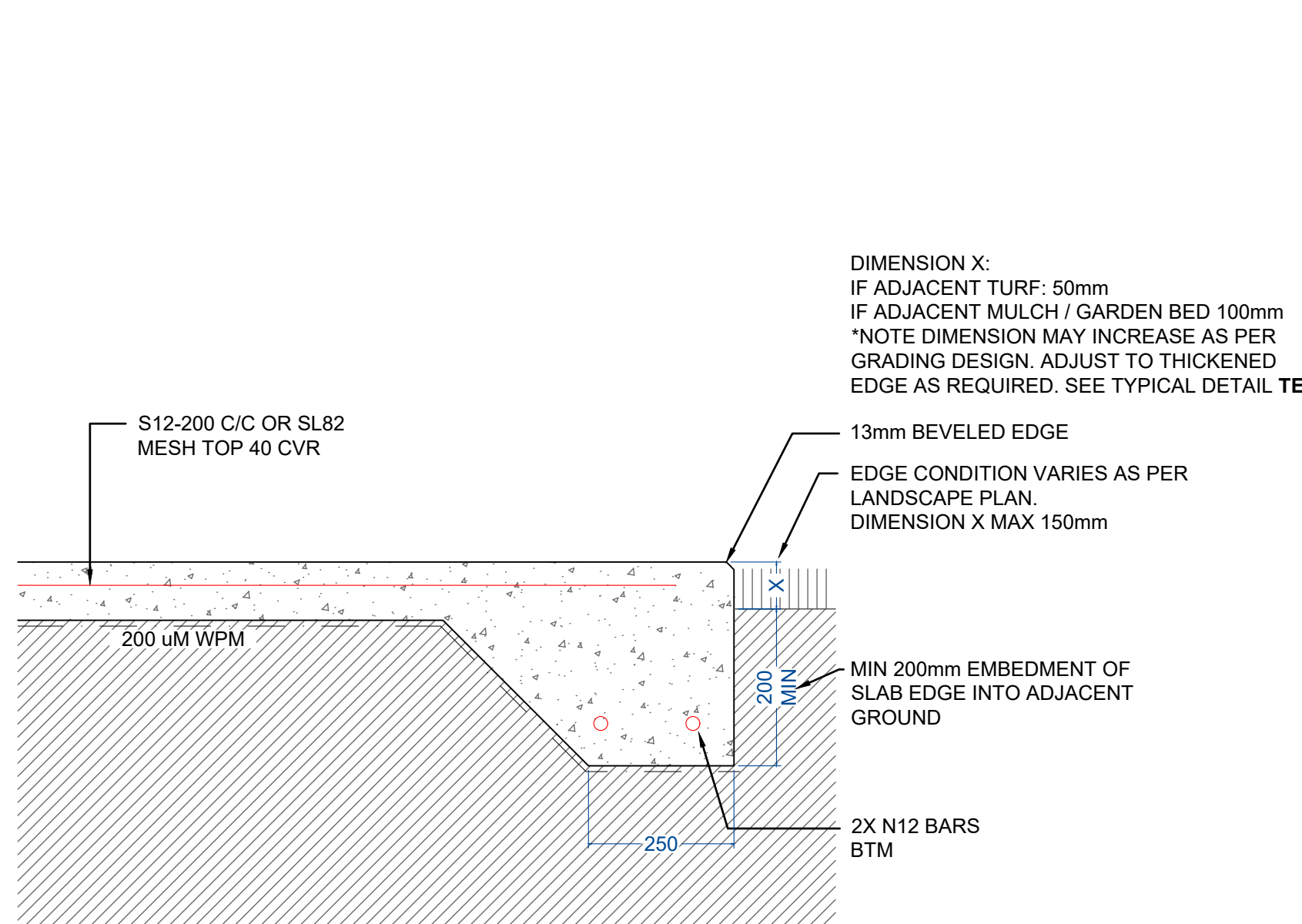
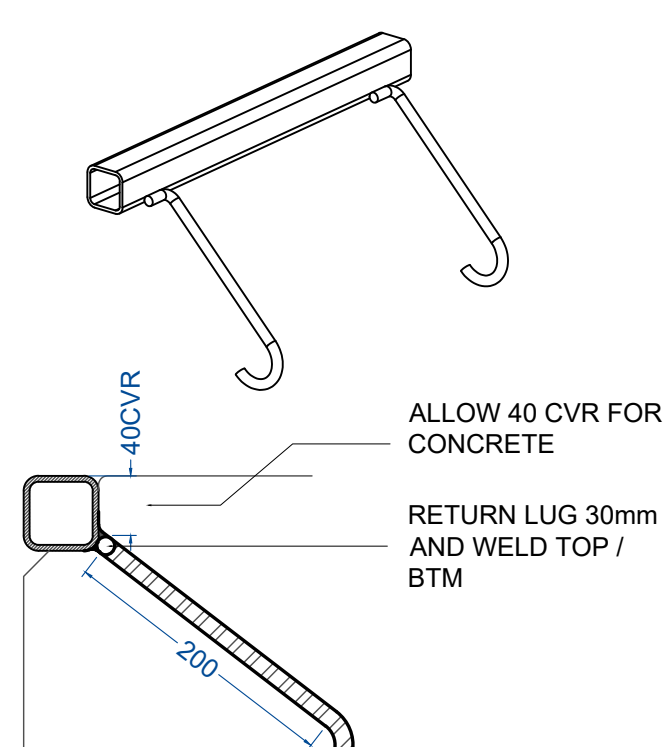

**TSE TYPICAL EDGE OF SLAB**  
1:10

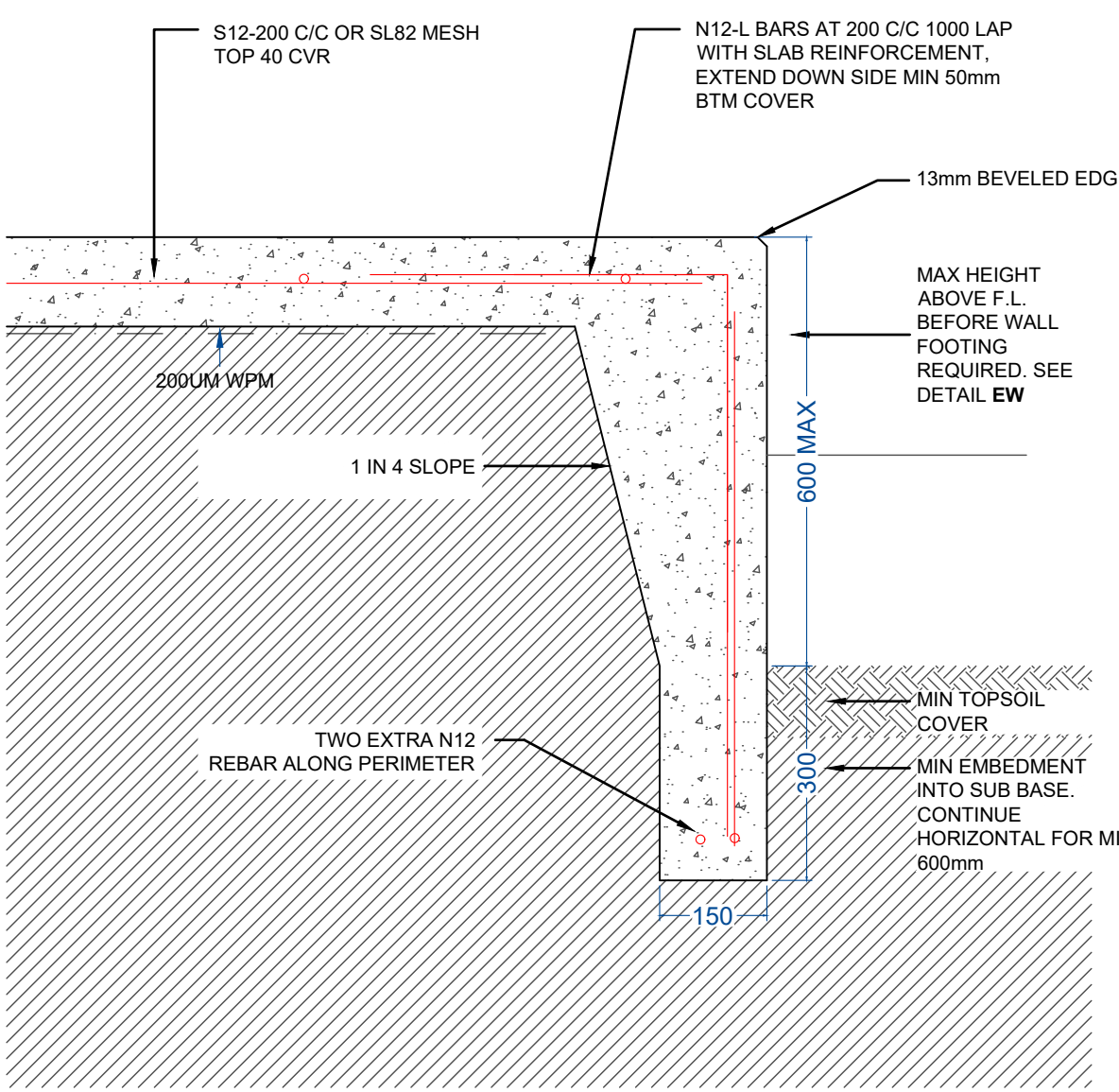

**TE TYPICAL THICKENED EDGE**  
1:10

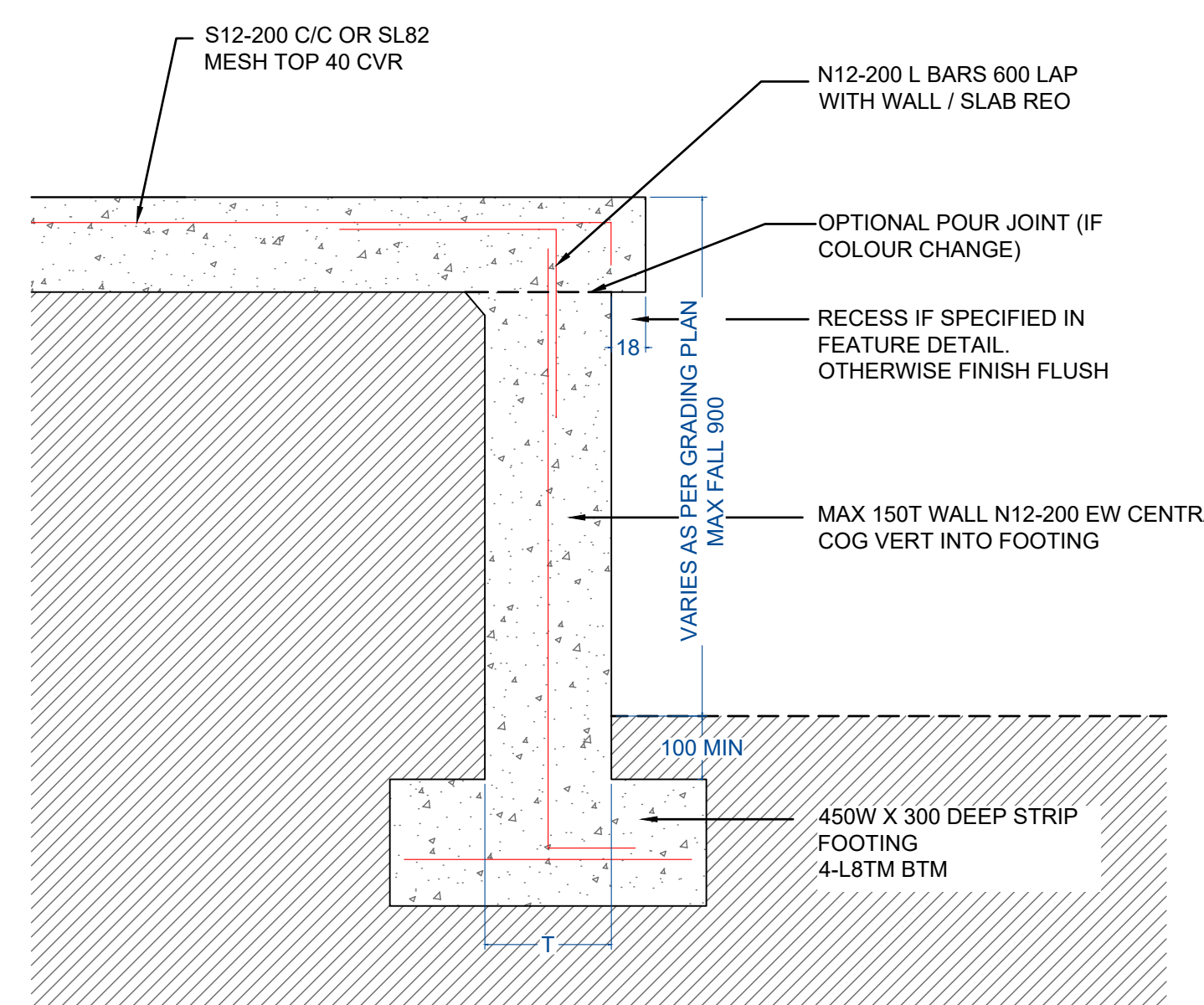

**EW TYPICAL EDGE WALL**  
1:10

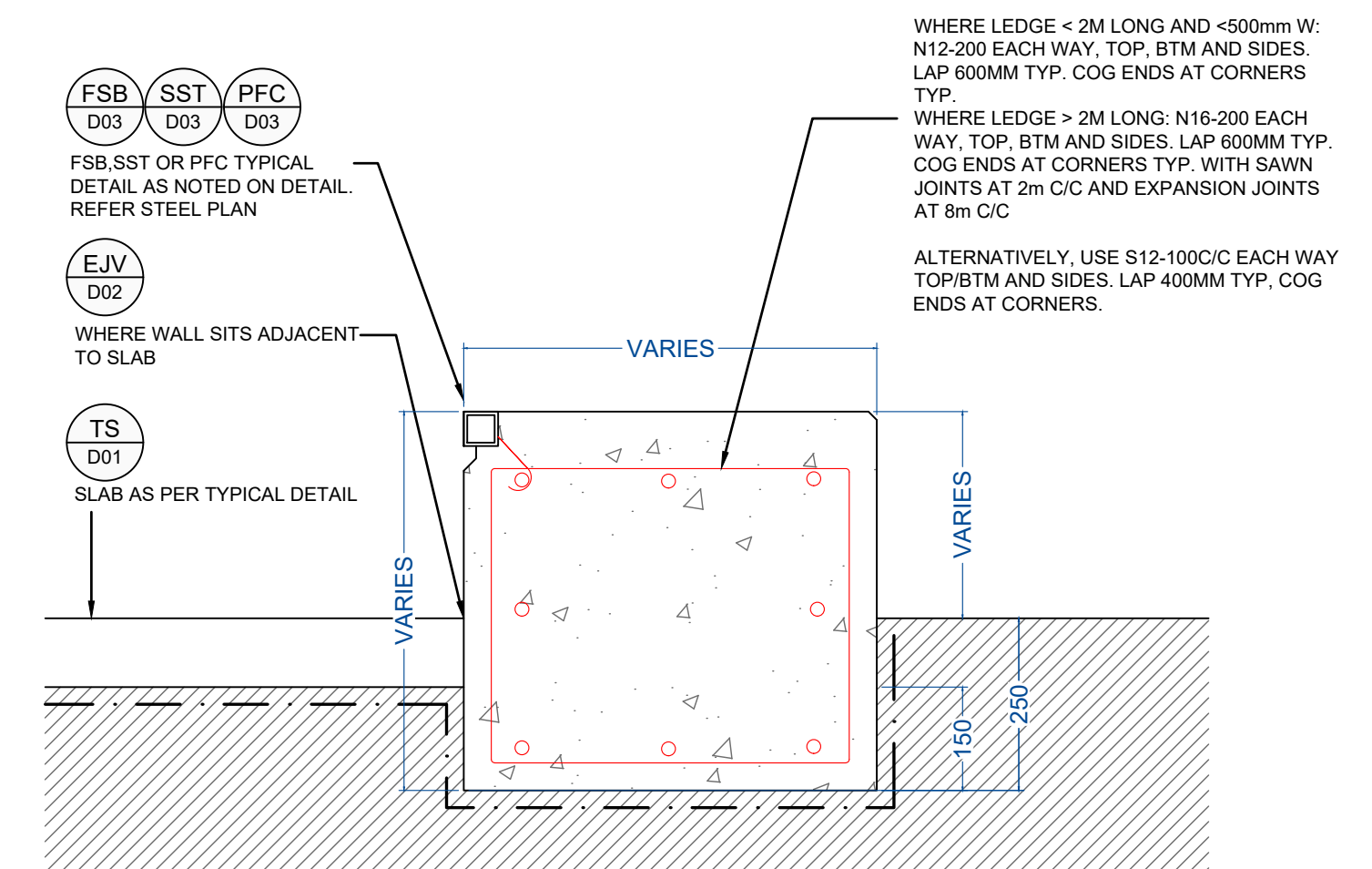

**TL TYPICAL LEDGE / SEAT WALL**  
1:10

WHERE LEDGE < 2M LONG AND < 500mm W: N12-200 EACH WAY, TOP, BTM AND SIDES. LAP 600MM TYP. COG ENDS AT CORNERS TYP.  
 WHERE LEDGE > 2M LONG: N16-200 EACH WAY, TOP, BTM AND SIDES. LAP 600MM TYP. COG ENDS AT CORNERS TYP. WITH SAWN JOINTS AT 2m C/C AND EXPANSION JOINTS AT 8m C/C  
 ALTERNATIVELY, USE S12-100C/C EACH WAY TOP/BTM AND SIDES. LAP 400MM TYP. COG ENDS AT CORNERS.